



QCEC

“Dependability Defined”

Century 3000 QLS ***Wall-Mount Indoor Wastewater Sampler***



Operations and Maintenance Manual **Rev. A, February 2025**

Part Number: 69-2303-412



4700 Superior Street • Lincoln, NE 68504
(402) 464-0231 • (800) 228-4373
www.teledyneisco.com

Teledyne ISCO is a world leader in automatic water sampling and open channel flow monitoring products. We have been in business for over 50 years manufacturing a wide range of products for professionals working in water pollution monitoring and abatement, engineers and managers involved with wastewater process control, and scientists involved in field and laboratory work. We take pride in the fact that the products we produce are used by our customers to improve the quality of life on Earth.

We offer all our customers responsive, competent, and excellent service and support. Our customers are the most important part of our business, and we work tirelessly to ensure your complete satisfaction. Provided below are key contact information so that you can reach us at your convenience.

Water & Wastewater Product Support:

Telephone	(402) 853-5350
Toll Free (USA)	(866) 298-6174
Email	iscowatersupport@teledyne.com

Teledyne ISCO

4700 Superior Street
PO Box 82531
Lincoln, NE 68501

Telephone	(402) 464-0231
Fax	(402) 464-0318
Toll Free (USA)	(800) 228-4373
Website	www.teledyneisco.com

Teledyne Isco Two Year Limited Factory Service Warranty*

This warranty exclusively covers Teledyne Isco instruments, providing a two-year limited warranty covering parts and labor.

Any instrument that fails during the warranty period due to faulty parts or workmanship will be repaired at the factory at no charge to the customer. Teledyne Isco's exclusive liability is limited to repair or replacement of defective instruments. Teledyne Isco is not liable for consequential damages.

Teledyne Isco will pay surface transportation charges both ways within the 48 contiguous United States if the instrument proves to be defective within 30 days of shipment. Throughout the remainder of the warranty period, the customer will pay to return the instrument to Teledyne Isco, and Teledyne Isco will pay surface transportation to return the repaired instrument to the customer. Teledyne Isco will not pay air freight or customer's packing and crating charges. This warranty does not cover loss, damage, or defects resulting from transportation between the customer's facility and the repair facility.

The warranty for any instrument is the one in effect on date of shipment. The warranty period begins on the shipping date, unless Teledyne Isco agrees in writing to a different date.

Excluded from this warranty are normal wear; expendable items such as desiccant, pH sensors, charts, ribbon, lamps, tubing, and glassware; fittings and wetted parts of valves; check valves, pistons, piston seals, wash seals, cylinders, pulse damper, diaphragms, inlet lines and filter elements, and damage due to corrosion, misuse, accident, or lack of proper maintenance. This warranty does not cover products not sold under the Teledyne Isco trademark or for which any other warranty is specifically stated.

No item may be returned for warranty service without a return material authorization number issued by Teledyne Isco.

This warranty is expressly in lieu of all other warranties and obligations and Teledyne Isco specifically disclaims any warranty of merchantability or fitness for a particular purpose.

The warrantor is Teledyne Isco, 4700 Superior, Lincoln, NE 68504, U.S.A.

*** This warranty applies to the USA and countries where Teledyne Isco does not have an authorized dealer. Customers in countries outside the USA, where Teledyne Isco has an authorized dealer, should contact their Teledyne Isco dealer for warranty service.**

Before returning any instrument for repair, please call, fax, or e-mail the Teledyne Isco Service Department for instructions. Many problems can often be diagnosed and corrected over the phone, or by e-mail, without returning the instrument to the factory.

Instruments needing factory repair should be packed carefully, and shipped to the attention of the service department. Small, non-fragile items can be sent by insured parcel post. **PLEASE BE SURE TO ENCLOSE A NOTE EXPLAINING THE PROBLEM.**

Shipping Address: Teledyne Isco - Attention Repair Service
4700 Superior Street
Lincoln, NE 68504 USA

Mailing Address: Teledyne Isco
PO Box 82531
Lincoln, NE 68501 USA

Phone: Repair service: (800) 775-2965 (lab instruments)
(866) 298-6174 (samplers & flow meters)
Sales & General Information: (800) 228-4373 (USA & Canada)

Fax: (402) 465-3001

Email: IscoService@teledyne.com



January 10, 2017 P/N 60-1002-041

Table of Contents

Warranty	2
Table of Contents.....	3
List of Illustrations	5
List of Tables.....	5
Configuration Quick Start.....	6
Composite Sample Storage.....	8
Operation Quick Start	9
Chapter 1: Introduction.....	10
1.1: Physical Description.....	10
1.1.1: Sample Collection System.....	12
1.1.2: Sampling Control System.....	12
1.1.2.1: User Interface Panel.....	13
1.1.2.2: Inputs and Outputs	13
1.1.3: Sample Storage System.....	13
1.2: Sampling Programs.....	14
Chapter 2: Installation.....	15
2.1: Positioning Considerations.....	15
2.2: Sampling Line Connection	16
2.3: Velocity Valve Adjustment.....	16
2.4: Field I/O Connections.....	17
2.4.1: Flow Inputs.....	17
2.4.2: Relay Outputs	18
2.4.3: Float Input.....	18
Chapter 3: User Interface Panel.....	19
3.1: Menu System.....	20
3.2: Administration Menu	22
3.2.1: Administration Password.....	22
3.2.2: Clock Settings.....	24
3.2.3: LCD Brightness.....	25
3.2.4: Archival Data Administration	25
3.2.5: Set ID Number.....	26
3.2.6: Set Volumetric Units.....	26
Chapter 4: Sampling Program Configuration.....	27
4.1: Program Selection	27
4.2: Program Configuration Groups	28
4.3: Sampling Cycle Settings.....	29
4.3.1: Pre-Sampling Purge Duration	29
4.3.2: Sample Size.....	30
4.3.3: Post-Sampling Purge Duration.....	30
4.3.4: Line Conditioning Rinses.....	31
4.3.5: Incomplete Sample Recycling.....	32
4.3.6: Consecutive Sampling.....	32
4.4: Sampling Intervals.....	33
4.4.1: Timed Interval Sampling	34
4.4.1.1: Fixed Length Time Intervals	34

4.4.1.2: Variable Length Time Intervals.....	35
4.4.2: Flow Interval Sampling.....	36
4.4.2.1: Analog Flow Input.....	37
4.4.2.1.1: Fixed Volume Flow Intervals.....	38
4.4.2.1.2: Variable Volume Flow Intervals.....	38
4.4.2.2: Pulsing Flow Input.....	39
4.4.2.2.1: Fixed Pulses Flow Intervals.....	39
4.4.2.2.2: Variable Pulses Flow Intervals.....	40
4.4.3: Time+Flow Interval Sampling.....	40
4.5: Bottle Options.....	41
4.6: Program Run Options.....	42
4.6.1: Automatic Rerun.....	43
4.6.2: Delayed Start.....	43
4.6.3: Fault Option.....	44
4.6.4: Float Option.....	44
4.6.5: Timed Stop.....	45
4.6.6: Bottle Limit Override.....	46
4.7: Program Events.....	47
4.7.1: Reviewing Scheduled Events.....	47
4.7.2: Adding and Editing Events.....	48
4.7.3: Deleting Events.....	50
4.7.4: Disabling Events.....	51
Chapter 5: Sampler Operation.....	52
5.1: Ready State.....	53
5.2: Sampler Conditions.....	54
5.3: Starting the Selected Program.....	54
5.3.1: Timed-Delay Starting.....	54
5.3.2: Float-Delayed Starting.....	55
5.3.3: Timed Starting.....	55
5.3.3.1: Timed State.....	56
5.3.4: Scheduled Starting.....	56
5.4: Running State.....	57
5.4.1: Sampling Intervals.....	58
5.4.2: Sample Container Screens.....	58
5.4.3: Sampling Cycle.....	59
5.4.3.1: Incomplete Sample Recycling.....	60
5.4.3.2: Manual Sampling.....	61
5.5: Paused and Halted States.....	61
5.5.1: Float Suspended Sampling.....	62
5.6: Stopping the Program.....	63
5.6.1: Continuous Operation.....	63
Chapter 6: Maintenance.....	64
6.1: Cleaning the Sampler.....	64
6.2: Compression/Vacuum Pump.....	64
6.3: Fuse.....	64
6.4: Troubleshooting Tips.....	65
Appendix A: Controller Capabilities.....	67

A.1: Overview	67
A.1.1: Supervisory Routine (Ready State).....	67
A.1.2: Menu System Outline	68
A.2: Inputs and Outputs	70
A.2.1: Run-Status Output	70
A.2.2: Alarm Output.....	70
A.2.3: Sampling Outputs.....	70
A.2.4: Load Cell Controller.....	71
A.2.5: Float Input.....	71
A.2.5.1: Factory Menu Float Setting.....	71
A.2.6: Flow Input.....	72
A.2.6.1: Remote Sample Initiation	72
A.3: Sampling Program.....	74
A.3.1: QLS Sampling Cycle.....	74
A.3.1.1: Automatic Calibration	75
A.3.1.2: Sample Recycling.....	75
A.3.2: Sampling Intervals.....	76
A.3.2.1: Variable Intervals.....	76
A.3.3: Bottle Options.....	77
A.3.4: Delayed Starting.....	77
A.3.5: Timed Stopping.....	78
A.3.6: Scheduled Events	79
Appendix B: Replacement Parts	80

List of Illustrations

Figure 1-1: QLS Wall-Mounted Sampler Component Locations	11
Figure 2-1: Flow Input Connections.....	17
Figure 2-2: Relay Output and Float Input Connections.....	18
Figure 3-1: User Interface Panel.....	19
Figure 6-1: QLS Compressor/Vacuum Pump and Service Kit.....	64
Figure A-1: QLS Flow Sequencing.....	73
Figure A-2: QLS Sampling Cycle.....	74
Figure A-2: Basic Sample Timing Diagram	76
Figure B-2: QLS Top-Feed Sample Chamber	82

List of Tables

Table 5-1: User Interface Panel and Icons	52
Table A-1: Available Program Event Types.....	79
Table B-1: Electrical System Parts.....	80
Table B-2: Control System Parts.....	80
Table B-3: Intake and Discharge Line Parts	81
Table B-4: Vacuum/Pressurization System Parts.....	81
Table B-5: Top-Feed Sample Chamber Parts.....	81

Configuration Quick Start

The following procedure configures a QLS sampler's program 1 to collect 100 milliliter samples at 20 minute intervals:

1. Power up the sampler to display its Program 1 READY screen, then press F3 three times to access that program's sampling Cycle settings:



2. Press F3 again to display the PREPURGE setting. Then type the number of seconds the sample chamber should be pressurized to clear the intake prior to each sample (e.g., 20):

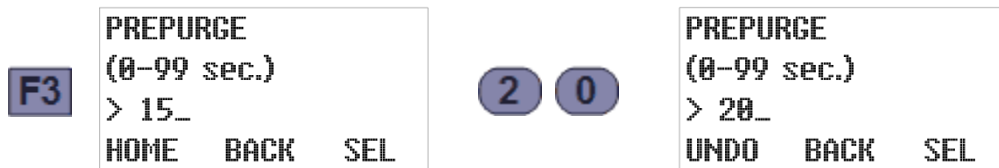

3. Press F3 to accept that Prepurge duration and view the SAMPLE SIZE. Then type the number of milliliters/grams of wastewater each cycle should draw (e.g., 100):

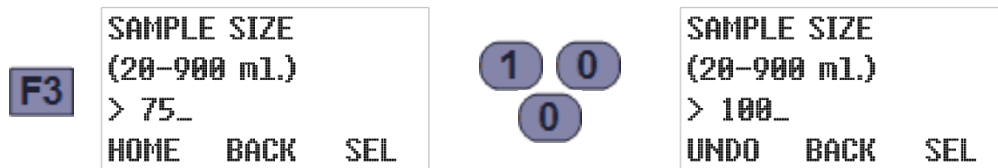

4. Press F3 to accept that size and view the POSTPURGE setting. Then type the number of seconds the sample chamber should be pressurized to clear the intake after each sample (e.g., 18):

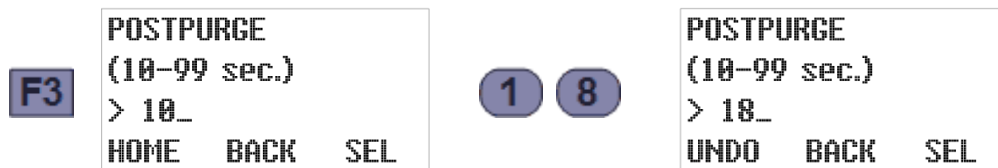

5. Press F3 to accept that setting and view the number of times the intake line should be rinsed prior to each sample. Then type the desired NUMBER of RINSES (e.g., 2):



6. Press F3 to accept that setting. If it is not zero, the rinse cycle PRESSURE TIME will then be displayed. Then type the number of seconds each rinse should pressurize the sample chamber (e.g., 8):



- Press F3 to accept that setting and view the rinse cycle VACUUM TIME. Then type the number of seconds each rinse should suction in wastewater (e.g., 6):

F3	VACUUM TIME (0-99 sec.) > 2_	6	VACUUM TIME (0-99 sec.) > 6_
	HOME BACK SEL		UNDO BACK SEL

- Press F3 to accept that setting and view the RECYCLE setting. Then type 0 to disable or 1 to enable the incomplete sample retry feature:

F3	RECYCLE Toggle ↑↓ > OFF	1	RECYCLE Toggle ↑↓ > ON
	BACK TGL SEL		BACK TGL SEL

- Press F3 to accept that setting and view the CONSECUTIVE SAMPLING setting. To draw just one sample per interval, type 1 (if necessary) to disable that feature:

F3	CONSECUTIVE SMP (1-24) > 1_	1	CONSECUTIVE SMP (1-24) > 1_
	HOME BACK SEL		UNDO BACK SEL

- Press F3 to accept that setting and return to the PROGRAM CONFIG menu:

F3	PGM CONFIG Use ↑↓ to select > SmpL. Interval
	HOME BACK SEL

- Press F3 to view the selected SAMPLING INTERVAL type. To change it, use the Up or Down key to scroll to the desired interval type (e.g., timed intervals):

F3	SMPL. INTERVAL Use ↑↓ to select > Flow	↑ or ↓	SMPL. INTERVAL Use ↑↓ to select > Time
	HOME BACK SEL		HOME BACK SEL

- Press F3 to accept that setting and view its current TIME OPTION. To change it, use the Up or Down key to scroll to the desired option (e.g., fixed time intervals):

F3	TIME OPTION Use ↑↓ to select > Time Variable	↓ or ↑	TIME OPTION Use ↑↓ to select > Time Fixed
	HOME BACK SEL		HOME BACK SEL

- Press F3 to accept that option and view its current SAMPLE MINUTES setting. Then type the desired new interval duration (e.g., 20 minutes):

F3	SMPL MIN (1-9999) > 30_	2 0	SMPL MIN (1-9999) > 20_
	HOME BACK SEL		UNDO BACK SEL

Composite Sample Storage

The following additional steps would configure a composite sampler to collect those samples for 16 hours, deposit all 48 of them into a 2.5-gallon container, and then stop:

- Press F3 twice to accept that interval, return to the PROGRAM CONFIG menu, and display the installed SAMPLE STORAGE TYPE (always composite for wall-mount samplers):



- Press F3 to accept that setting and view the COMPOSITE SIZE setting. Then use the Up or Down key to scroll to the installed sample container size (e.g., 2.5 gallons):

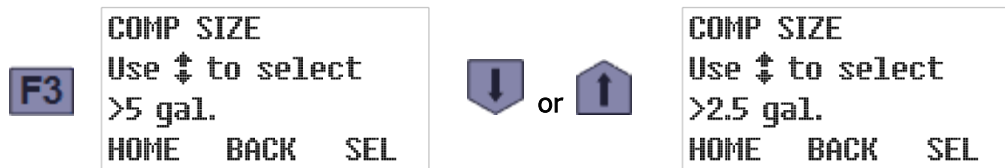

- Press F3 to accept that setting and view the number of samples the container is currently set to receive. Then type the number of samples you want the program to collect (e.g., 48):

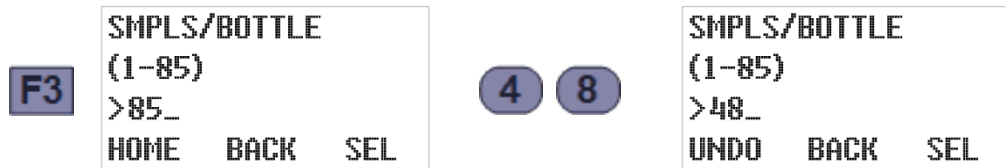

- Press F3 to accept that setting and return to the PROGRAM CONFIG menu. Assuming you don't want to enable any PROGRAM RUN OPTIONS (which are all disabled by default), press F1 twice to display the PROGRAM READY screen:



- Twenty minutes before the first sample is to be drawn, press F1 to start the sampling program. Barring unforeseen problems, that program would then run for 16 hours and stop:

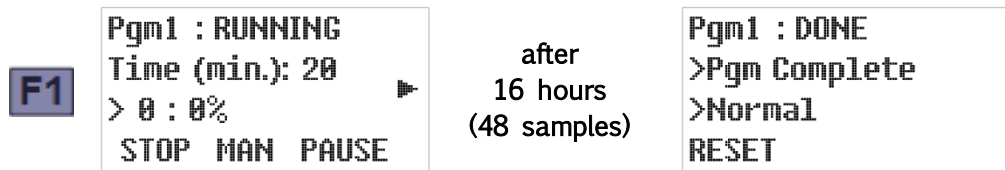

- You should then replace the sample container with an empty one and press F1 to reset the program. Then repeat Step 19 twenty minutes before you want to start the next day's sampling.

Operation Quick Start

When powered up, the controller first displays one of its [Ready screens](#) (see page 53). All you need to do is start the indicated sampling program by pressing the RUN [F1] key:

sampler powers up	<pre>Pgm1 : READY Time (min.): 60 > 0 : 0% RUN TIMED MENU</pre>	<div style="border: 1px solid black; padding: 2px 10px; display: inline-block;">F1</div>	<pre>Pgm1 : RUNNING Time (min.): 60 > 0 : 2% STOP MAN PAUSE</pre>

The indicated time or flow interval counter will then accumulate until it reaches 100 percent of its target value, at which time the [sampling cycle](#) will be initiated (see page 59):

interval reaches 100%	<pre>SAMPLING rinse press... sec: 14 STOP</pre>	or	<pre>SAMPLING prepurge... sec: 12 STOP</pre>

After the sample has been discharged to its storage container, the previously-displayed Running screen will reappear. The program will continue running until the specified number of samples has been collected, then stop and display its DONE screen. Alternately, you can manually stop it at any time by pressing the STOP [F1] key:

after last sample is collected	<pre>Pgm1 : DONE >Pgm Complete >Normal RESET</pre>	OR	<div style="border: 1px solid black; padding: 2px 10px; display: inline-block;">F1</div>	<pre>Pgm1 : STOPPED >Pgm Stopped >From Keypad RESET</pre>

In either case, the program's sample counters must then be reset (by pressing the RESET [F1] key) before another round of sampling can be initiated. Before doing so, remove the samples and install an empty container or bottle carousel.

The unit's operation can be further simplified by setting the [Bottle Limit](#) option (see page 46) to "Program Continue". The program would then continue sampling indefinitely, without requiring anyone to ever press the RESET [F1] key.

As the program would then have no way of knowing how many samples it has discharged since the container was last emptied, the sample count screen (see page 58) merely indicates "NL" (no limit). However, a composite sampler equipped with a bottle-full float switch would suspend its interval counters (and display a downward-pointing float icon) if that switch ever opened, then restart them from zero as soon the container was replaced (thus reclosing the switch):

if composite container filled up	<pre>Pgm1 : RUNNING Smp1#:NL 12:34:56 07/08/15 STOP MAN PAUSE</pre>	<div style="border: 1px solid black; padding: 2px 10px; display: inline-block;">F1</div>	<pre>Pgm1 : RUNNING Time (min.): 60 > 0 : 0% STOP MAN PAUSE</pre>

Chapter 1: Introduction

QLS Wall Mount Samplers collect specified volumes of wastewater at programmed time or flow intervals and deposit them into external composite sample containers. Their patented **Quick Lift Sampler (QLS)** systems precisely weigh each sample and self-calibrate to maintain the specified sample size. Their piston vacuum pumps provide long-term consistent sampling with vertical lifts of up to 28 feet, with no need to frequently replace the internal tubes that render peristaltic pumps inconsistent, unreliable and costly to maintain.

- ⊘ *The QLS vacuum system cannot be used to sample pressurized wastewater streams, or open streams whose surfaces are higher than the sampler. Attempting to do so will ruin the sampler by filling it with water.*

If you have any questions or suggestions, feel free to call QCEC at 1-515-266-2268 and ask for wastewater sampling technical support.

1.1: Physical Description

Each QLS Wall Mount Sampler includes **sample collection** and **sampling control** systems mounted in a durable plastic housing with a clear access door. The interior of that housing is divided by an aluminum partition that protects the electrical components and provides a mounting surface for the user interface panel.

Unlike our other sampler models, these units do not include **sample storage** compartments and containers. Each must instead be provided with a suitable customer-provided composite sample container, which might or might not need to be housed in a refrigerated compartment.

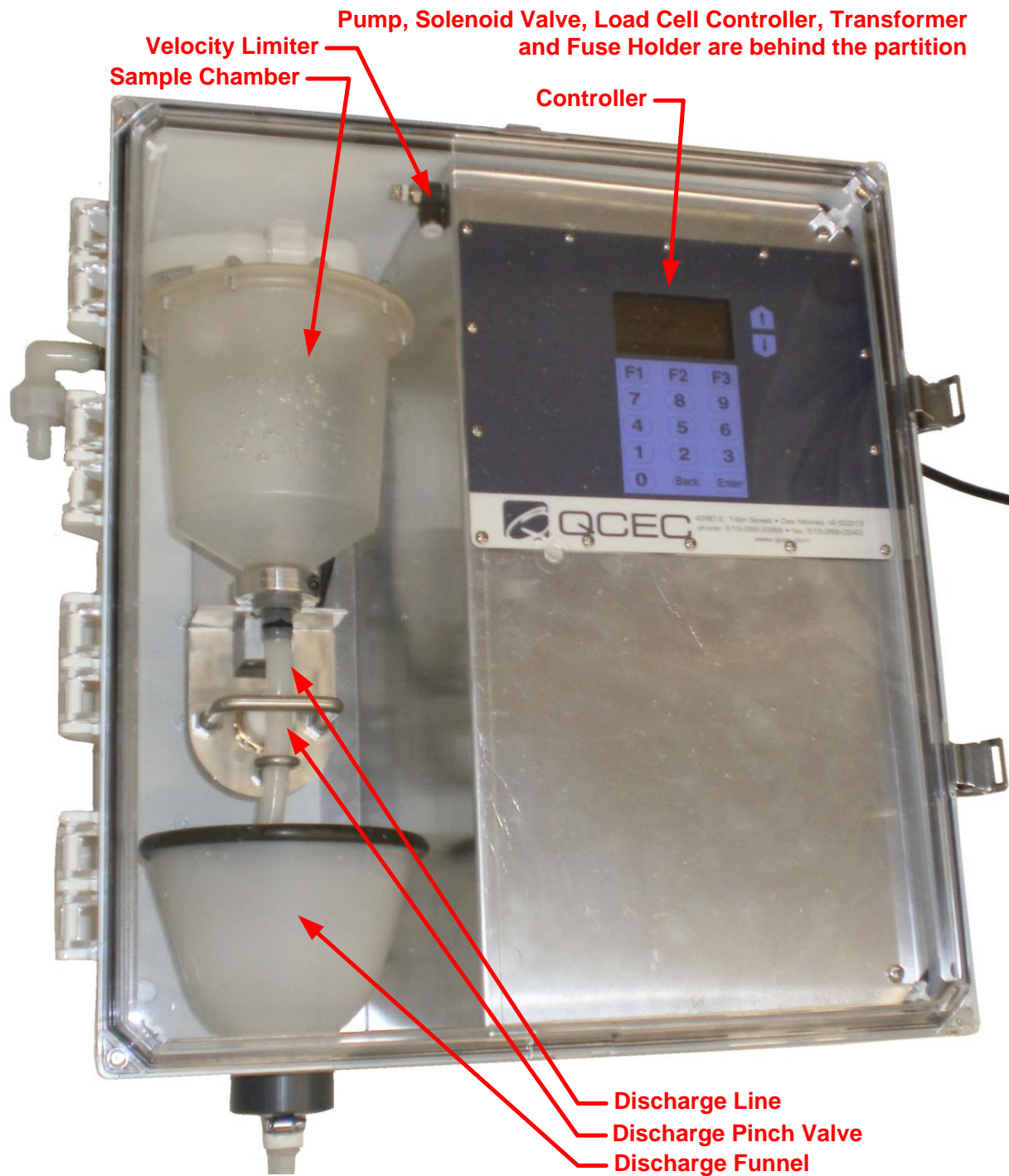

Figure 1-1: QLS Wall-Mounted Sampler Component Locations

1.1.1: Sample Collection System

The sample collection system has the following major components (see [Figure 1-1](#)):

- A clear plastic **sample chamber** with an attached discharge-tube **pinch valve**.
- A **load cell** (and its control unit) that continuously weighs the sample chamber as each sample is being drawn.
- A 120 VAC piston **air compressor/vacuum pump** connected to that chamber by a four-way **solenoid valve**, which alternately evacuates and pressurizes the sample chamber in order to draw wastewater in and force it back out.
- A pump discharge **pressure regulator** and an intake **velocity-limiting valve**.
- A **discharge funnel** that directs the samples to an external container via a 3/8 inch clear **external discharge tube** (this isolates the load cell from the discharge tube and any forces exerted on it).
- A 3/8 inch clear **stream sampling tube** that extends to an unpressurized wastewater stream whose surface is at a lower elevation than the sampler.

The velocity-limiting valve is mounted to the protective partition, while the load-cell controller, pump, solenoid and pressure regulator are located behind it. For 240VAC units, that protected area also houses a 240-to-120 VAC transformer.

1.1.2: Sampling Control System

The QLS sampling control system includes two circuit boards that are referred to as the **logic** and **power** boards. They collectively provide the following features:

- a 32-bit microcontroller that can run any of six **sampling programs**
- a **backup battery** that powers the microcontroller's **real-time clock** but not its field elements (thus precluding continued sampling) when external power is unavailable
- the onboard **user interface**
- a variety of discrete and analog **inputs and outputs** (see next page)
- an **SDI-12 communication interface** for the load cell controller
- the following communication ports (not yet implemented or unused by this model):
 - a USB-A **thumb drive** port (for archival data transfer)
 - USB-B and RS232 **Modbus ports**

The logic board (which includes the user interface components) is mounted on the protective partition, with the power board immediately behind it. That protected area also houses a step-down transformer and fuse for the control system.

1.1.2.1: User Interface Panel

The logic board's LCD readout and password-protected keypad are used to:

- adjust the clock and the LCD brightness/contrast, and administer the access passwords and archival data (see [Chapter 3: User Interface Panel](#));
- configure the sampling programs (see [Chapter 4: Sampling Program Configuration](#)); and
- monitor and control the unit's operation (see [Chapter 5: Sampler Operation](#)).

1.1.2.2: Inputs and Outputs

Each controller's logic board supports a variety of field input and output signals, some of which are wired directly to logic board connectors while others are routed through additional circuitry and connectors on the power board:

- All of the controller's required and optional inputs and outputs are described in detail in [Appendix A](#) (see page 70)
- Those circuits, and the circular plastic connectors (CPCs) to which the corresponding field devices must or can be wired, are shown on the [Electrical Diagram](#) appended to the back of this manual.
- Instructions for connecting your field devices to the controller's external CPCs are provided in [Chapter 2](#) (see page 16).

1.1.3: Sample Storage System

Wall-Mount Samplers are meant for composite-sampling applications, which discharge all samples into a single customer-supplied, external, presumably refrigerated storage container. The controller's discrete/sequential sampling features, which are only designed to work with QCEC's bottle turntable and carousels, are factory disabled.

1.2: Sampling Programs

The control system provides six user-configurable sampling programs, one of which is selected and can be run at any given time. Each of those programs can be configured to:

- draw configurable, fixed-size (20 to 500 milliliter) samples, or sets of consecutive samples, at specified time or flow intervals;
Flow intervals can be based on either an analog or a discrete-pulse flow meter signal, or a PLC or other remote device could use the pulsing flow input to trigger individual samples.
- rinse the sampling line up to four times prior to drawing each sample.
- repeat any sampling cycle up to four times (five total) if needed to collect the specified volume of wastewater.
- delay its execution a specified number of minutes after it is started, or until the optional float input is asserted.
- automatically stop after a configurable amount of time or number of samples, or if the discharged volumes exceed 90 percent of the sample container's capacity.

AND/OR

suspend and resume sampling as an optional external float switch opens and closes.

Alternately, a PLC or other remote device could use the external float-switch input to remotely suspend and resume the collection of samples.

- start sampling, pause or halt and later resume, take manual samples and finally stop at scheduled times on specified days of the week, then automatically restart itself if desired.
- energize a run-status relay to indicate a sample is being collected, or an alarm relay to indicate the program has stopped or encountered a fault condition.

Appendix A: [Controller Capabilities](#) discusses the configurable features of the sampling program, while Chapter 4: [Sampling Program Configuration](#) tells how to view and change the parameters that configure those features.

Chapter 2: Installation

Each QLS Wall Mount Sampler is meant to be used in a fixed location, with any optional external I/O devices connected, the far end of its sampling line fixed in the wastewater stream it is used to sample, its discharge funnel routed to a suitable sample container, and its power cord plugged into an AC power receptacle.

When you are ready to install your sampler:

1. Move it to its intended final location, remove it from its shipping carton and remove any internal packing materials.
2. Mount it on a vertical surface such that its horizontal surfaces are approximately level.
3. Position the wastewater intake strainer and connect it to the sampler's intake fitting using 3/8 inch clear, flexible tubing.
4. Route the discharge funnel's outlet to your sample container.
5. Connect any external I/O devices (flow and/or float input, run and/or alarm output).
6. Plug the provided power cord into a grounded AC power receptacle.
7. Verify or correct the control system clock settings (see page 24).
8. Configure the [sampling program\(s\)](#) to your needs (see page 27).
9. When lifting small samples, you may need to adjust the velocity valve (see next page).

2.1: Positioning Considerations

Your QLS Wall Mount Sampler can be installed in nearly any location, provided the wastewater stream from which the samples will be drawn is no more than 28 feet below the top of the sampler's housing.

The unit is equipped with a grounded 9-foot 14/3 AWG power cord that exits the upper right side of the housing. If an AC receptacle is not located within reach of that cord, a sufficiently-long, customer-provided appliance-quality 15-amp extension cord will be needed.

2.2: Sampling Line Connection

The wastewater inlet connection is a 1/2 inch FNPT fitting recessed into the left side of the sampler housing. You can connect any appropriate plumbing materials, but the most common choice is 3/8 by 5/8 inch (I.D. by O.D.) clear PVC tubing connected using a right-angle barbed or compression fitting. Either fitting and needed length of tubing can be purchased from QCEC.

If you are using tubing and a compression fitting obtained from QCEC:

1. Loosen (but do not remove) the compression nut.
2. Wet the end of the tubing and force it into the fitting as far as it will go.
3. Tighten the nut.

⚠ If you fully disassemble the fitting, there is a good chance the compression ring might fall out and be lost. Without it, you will be unable to obtain an airtight connection.

The far end of each tube is usually connected to an in-stream strainer, such as the stainless steel or PVC strainer available from QCEC. As shown to the right, both of them feature barbed fittings that the intake lines can be slipped over and clamped to.



⊘ The QLS vacuum system cannot be used to sample pressurized wastewater streams, or open streams whose surfaces are higher than the sampler. Attempting to do so will ruin the sampler by filling it with water.

2.3: Velocity Valve Adjustment

In order to raise small samples limited distances, you might need to open the velocity-limiting valve. For example, if you need to lift 100 milliliter samples less than three feet, you should start by opening that valve two turns from its factory setting.

As shown on [Figure 1-1](#), that valve is mounted to just to the right of the sample chamber:

- To open that valve, thus reducing the vacuum force applied to the sample chamber and the resulting water flow rate, turn the chrome knob counterclockwise.
- To close it, thus increasing the vacuum and flow rate, turn that knob clockwise.

2.4: Field I/O Connections

At least one circular plastic connector (CPC) is mounted in the upper right side of Optima and Premium (and both sides of Dual) cabinets for the field I/O devices:

- a four-pin flow inputs connector (analog and/or pulsing-discrete signals)
- an optional seven-pin field I/O connector (alarm and run output and float input signals)

Custom cables must be fabricated (from the provided matching screw-terminal cable connectors) for any you chose to use.

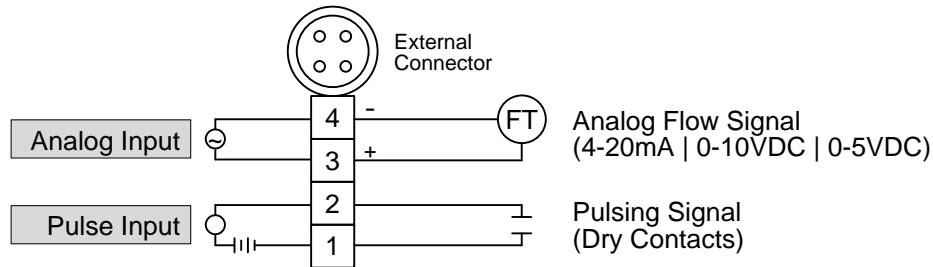

Figure 2-1: Flow Input Connections

2.4.1: Flow Inputs

The four-pin flow input connector provides field wiring terminals for pulse and analog flow input signals, either of which can be connected and used to trigger sample collection at configured stream [flow intervals](#) (see page 76):

- If that feature is configured for a pulsing input, connect a dry-contact signal source to input connector pins 1 and 2. The interval pulse count will be incremented each time that controller-powered circuit is externally closed.
- ✎ *To adapt this input to an externally-powered discrete signal, connect it to the normally-open contacts of an interposing relay and use that signal to energize the relay coil.*
- If that feature is configured for a 4-to-20 mA, 0-to-5 V or 0-to-10 V analog flow signal, connect the transmitter's positive (+) and negative (-) terminals to input connector pins 3 and 4, respectively.

QCEC offers both an open-channel ultrasonic flowmeter (the QC-OC-1) and a closed-channel Doppler flowmeter (the QC-DT-1), both of which provide both analog and pulsing discrete flow outputs that satisfy the requirements of our wastewater sampler flow inputs.

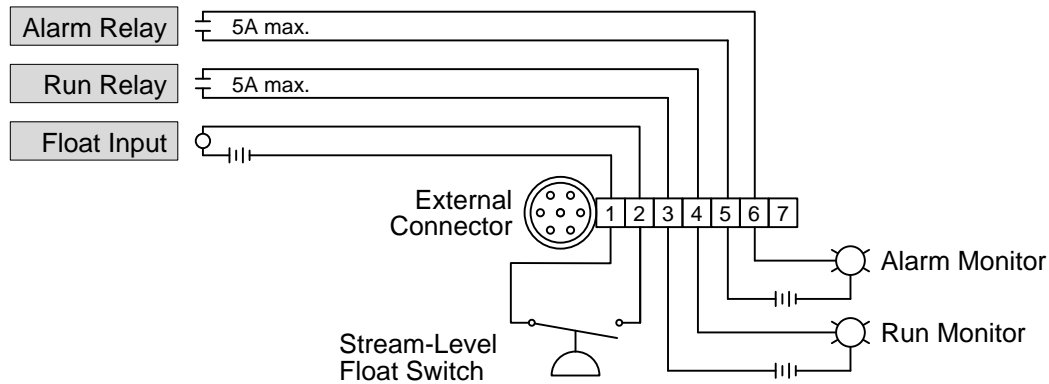

Figure 2-2: Relay Output and Float Input Connections

2.4.2: Relay Outputs

As shown above, four of the optional field I/O connector's seven pins connect to 5 Amp relay contacts on the controller's power board:

- the run-status relay connects pins 3 and 4 when the unit is **sampling** (see page 74)
- the alarm relay (if enabled, see page 44) connects pins 5 and 6 when sampling is stopped or certain non-fatal **fault conditions** are detected (see page 70).

They can thus be used to turn appropriate *externally-powered* indicator lamps or annunciators on and off, or to signal those conditions to a SCADA or other host control system.

2.4.3: Float Input

Pins 1 and 2 of the optional seven-pin field I/O connector, which are internally wired to the controller's self-powered float input, can be used to externally connect a dry-contact, normally-open, minimum-stream-level float switch.

Depending on which of the **Float Input** options has been factory-configured (see page 71), enabling this input (see page 44) will configure the sampling program to delay sample collection until that circuit closes and subsequently either:

- continue sampling even if the float circuit reopens, or
- toggle the collection of samples on and off as the rising and falling stream level closes and opens that circuit.

Due to the variety of suitable stream-level sensors that are available, QCEC neither recommends nor sells them—you must select and obtain one from a third-party supplier.

Chapter 3: User Interface Panel

The sampler's operation can be configured, monitored and controlled using its user interface panel, which consists of an LCD readout and password-protected keypad mounted behind the clear access door.

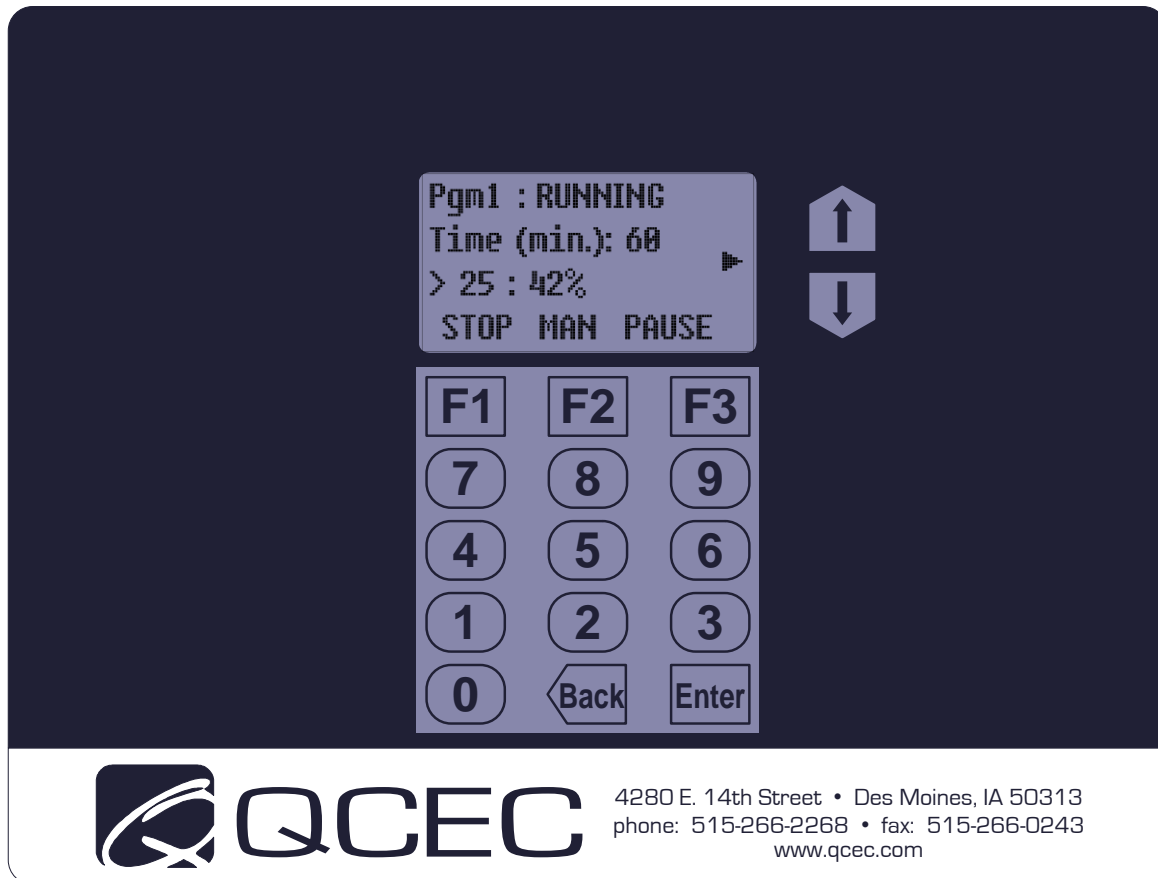

Figure 3-1: User Interface Panel

Its LCD readout displays the identity of the selected sampling program, which the operator can start and stop or pause and resume (see [Chapter 5: Sampler Operation](#)). It displays four lines of alphanumeric text, plus a column of status icons that might appear along its right edge:

- The top line identifies and displays that program's operating state. The second and third lines display sets of status information, which you can cycle through by pressing the UP and Down keys to the right of the LCD.
- The bottom line indicates the functions (if any) of the top three keys (F1, F2 and F3).
- Various status icons (see Table 5-1 on page 52) are displayed along the right edge of the readout (as you face it).
- *The display panel backlight will automatically turn off if no keyboard activity has been detected in the last two minutes. Pressing any key will then turn it back on.*

3.1: Menu System

The control system is set up and administered via a [hierarchical menu](#) (see page 68) accessed by pressing the F3 key when the prompt above it reads “MENU”. If the [administration password](#) (see page 22) has its default value (0), the first Main Menu option will then be displayed:



If that password has a non-zero value, the Password entry screen will appear instead. Like many other menu screens, it assigns the HOME, BACK and SEL[ect] functions to the F1, F2 and F3 keys:

- Pressing HOME [F1] generally displays the parent menu for the current screen. If you are editing settings, any changes you have made to the current parameter will not be saved.
- Pressing BACK [F2] or the [Back](#) (bottom row, center) key generally restores the previously-displayed screen or, if you are editing numerical parameter values, backspaces over the most-recently typed digit.
- Pressing SEL [F3] or the [Enter](#) (bottom row, right) key generally displays the next parameter or screen in a sequence. If you are editing settings, any changes you have made to the current parameter will be saved.

In this case, pressing HOME [F1] would restore the operating state display (as would BACK [F2] or the Back key before you start typing the password):



To access the Main Menu, use the numeric keys to type the correct password, then press SEL [F3] or the Enter key. If the password was 56, for example:



Typing the first digit changes the F1 prompt to UNDO—pressing that key would then clear any digits you had typed so far and restore the initial Password screen. In contrast, pressing BACK [F2] or the Back key will clear only the last typed digit.

Whenever any Main Menu screen is displayed, you can scroll through its four options by pressing the Up or Down key, display the first option of the indicated subordinate menu by pressing SEL [F3] or the Enter key, or exit the menu system by pressing HOME [F1]:

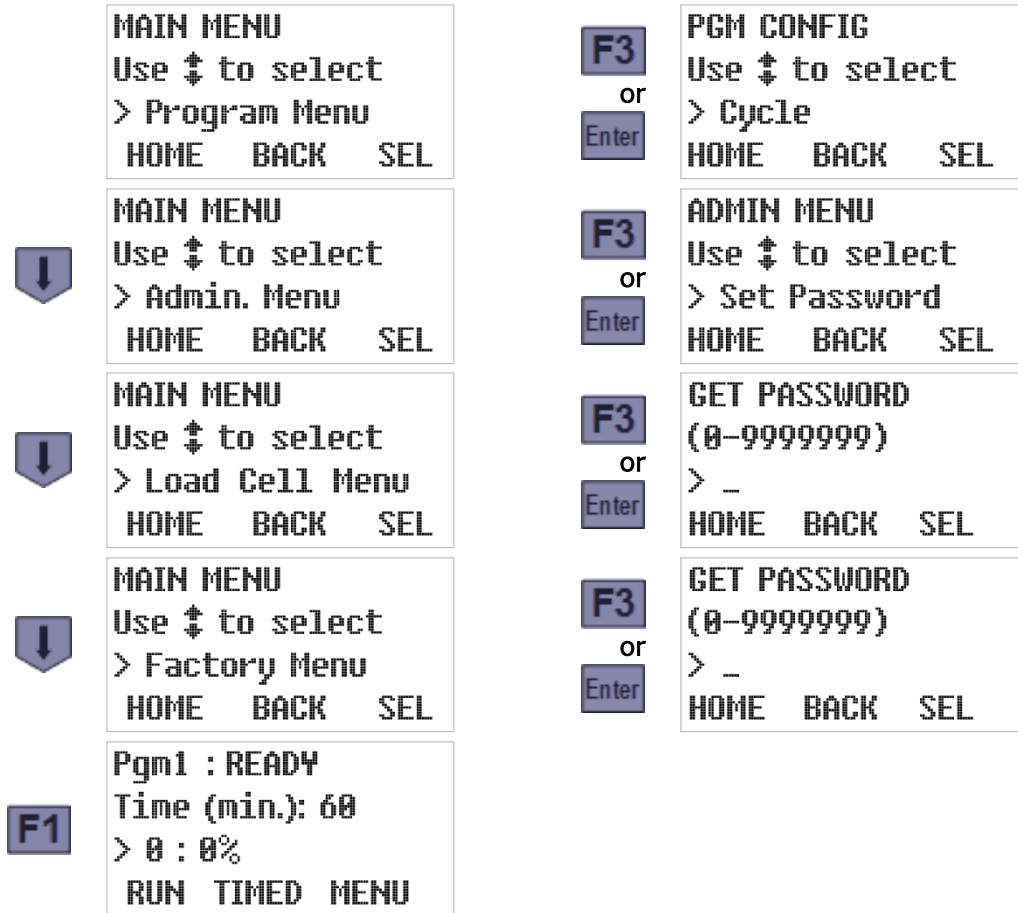

For convenience, each of those subordinate menus is set up so saving a setting (or initiating an action) automatically displays the next one. Also, pressing the Enter key (or SEL [F3], if available) when a setting's current value is first displayed leaves it unchanged. So you can advance through the entire menu, viewing but not changing any settings, by simply pressing the Enter key enough times.

⚠ Access to the Load Cell and Factory Menus, which are used to adapt each controller to its sampler prior to shipment, are restricted by additional secret passwords.

3.2: Administration Menu

Administration Menu screens can be used to:

- change or clear the [administration password](#) (see page 22),
- set the [real-time clock](#) and enable/disable daylight savings time (see page 24),
- adjust the [LCD brightness](#) (page 25),
- download and erase the [archived data](#) (see page 25),
- change the unit's [ID number](#) (page 26), and/or
- select English or Metric [volumetric units](#) (page 26).

To access those features:

1. Access the **Main Menu** by pressing the MENU [F3] key and (if so prompted) entering the optional password (see [Menu System](#) above).
2. Press the DOWN key to scroll to the **Administration Menu** option, then press the SEL [F3] or Enter key to display that menu's first option:

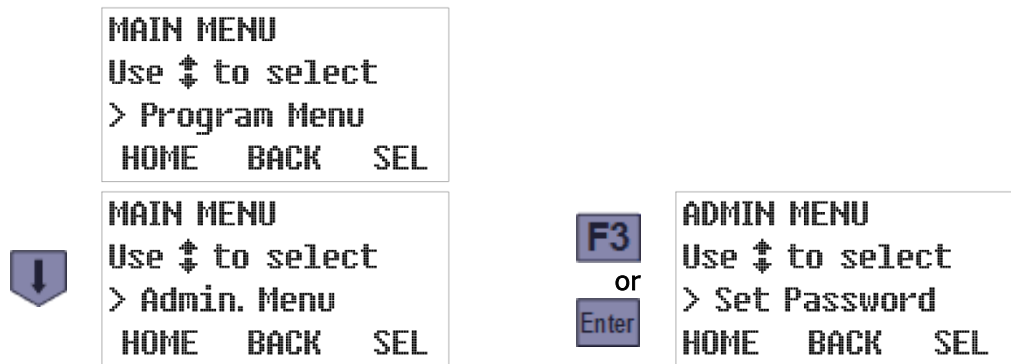

3.2.1: Administration Password

The [administration password](#) can be used to prevent unauthorized individuals from accessing the [Administration and Program menus](#) (see page 20):

- If it is set to zero (its factory default value), pressing the MENU [F3] key will immediately display the first Main Menu option.
- If it is assigned a value from 1 to 9,999,999 (leading zeroes are not allowed), pressing MENU [F3] will display the Password entry screen.

- ⚠ *The Load Cell and Factory Menus, which are meant to be used only by QCEC personnel, are protected by additional passwords that must be entered even if the administration password is cleared (set to zero).*
- ⚠ *If you forget the value of your administration password, contact QCEC for instructions on how to regain access to your sampler's menu system.*

To change the administration password's value:

1. Select the [Administration menu](#) (see page 22) to display its first option (Set Password). The second line of the readout will then show the range of allowable values while the third displays the current password:

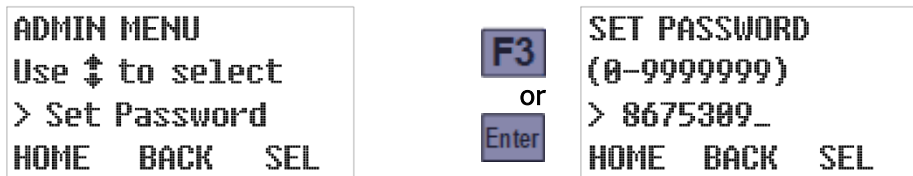

2. Type the new password by pressing the corresponding numeric keys (the old password will be erased and the F1 prompt will change from HOME to UNDO). Then press the SEL [F3] or Enter key to save the displayed password and advance to the next Administration Menu option. To change it to 56, for example, just press 5, then 6, and finally SEL [F3] or Enter. The new value will then be saved and the next Admin Menu option will be displayed:



While entering a new password:

- Pressing UNDO [F1] would restore the old password value.
- Pressing BACK [F2] or the Back key would delete the right-most typed digit. Backspacing over the first digit will restore the old password.

Setting the password to zero (0) removes any previously set Administration and Program Menu protection. An easier way to do that, however, is to execute the second Admin Menu option:

1. Select the [Administration Menu](#) (see page 22 and press the DOWN key to display its Clear Password option.
2. Press the SEL [F3] or Enter key to immediately set the password to zero. A STATUS UPDATE screen will appear briefly, followed by the next Administration Menu option:

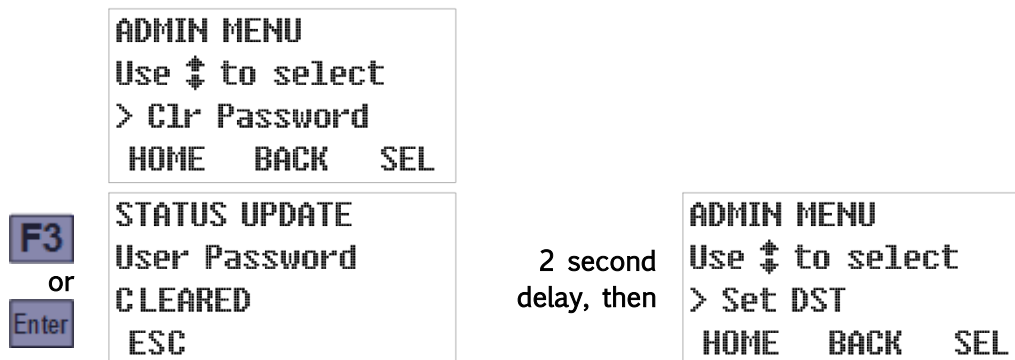

3.2.2: Clock Settings

The control board includes a real-time clock chip with a backup battery, so it runs even when the control board is powered down. This enables it to timestamp all archived data and to collect samples at scheduled times. In addition, the current time and date are displayed on the third line of the second operating [status screen](#) (see page 57).

The third Administration Menu option allows you to quickly adjust the clock by one hour when daylight savings time (DST) begins or ends, while the fourth allows you to directly reset the clock to the current date and time. Because you should make sure the DST option is correct before setting the time, those options should be executed in the order presented:

1. Select the [Administration Menu](#) (see page 22), use the Down key to scroll to its third (Set DST) option, and then press the SEL [F3] or Enter key. The third line of the readout will then show the current daylight savings time setting:

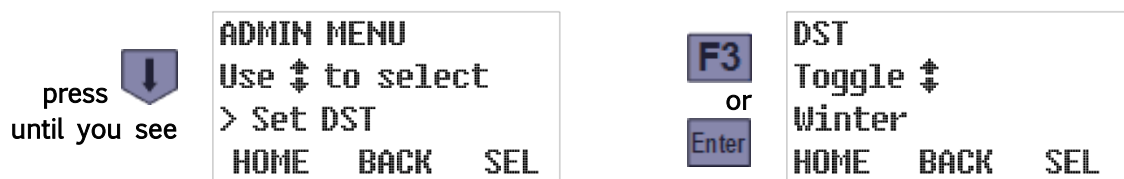

2. If necessary, press either the Up or the Down key to toggle that setting. When the desired setting is displayed, press the SEL [F3] or Enter key to save it and display the Set Clock option:



3. To adjust the date and time settings, press the SEL [F3] or Enter key. Otherwise, scroll to another Administration Menu option or press the HOME [F1] key to restore the Main Menu. The current date setting is displayed first. If it is correct, or after you have corrected it, press the Enter key to save the displayed date and access the current time setting:



The same techniques are used to change both settings. The third line displays the current value, with an underline cursor indicating the digit currently subject to editing:

- Press the Previous [F2] or Next [F3] key to move that cursor one digit left or right.
- Press any appropriate numeric key to set the current digit and advance the cursor, OR press the Up or Down key to increment or decrement the current digit.
- Press the ESC [F1] key to undo any change to the displayed setting and return to the Administration Menu/Set Clock screen.

- Pressing the Enter key while the time setting is displayed saves that time and displays the next Administration Menu option:

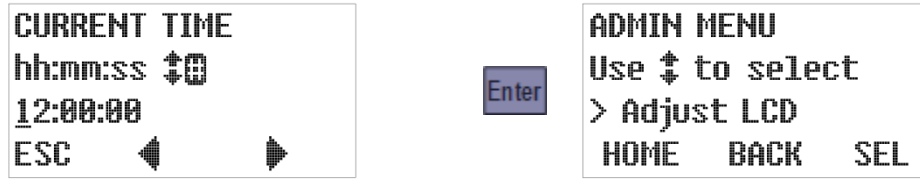

3.2.3: LCD Brightness

To adjust the brightness of the LCD backlight, which determines the contrast of the user interface panel:

- Select the [Administration Menu](#) (see page 22), use the Up or Down key to scroll to its fifth (Adjust LCD) option, and then press the SEL [F3] or Enter key to display the current setting:

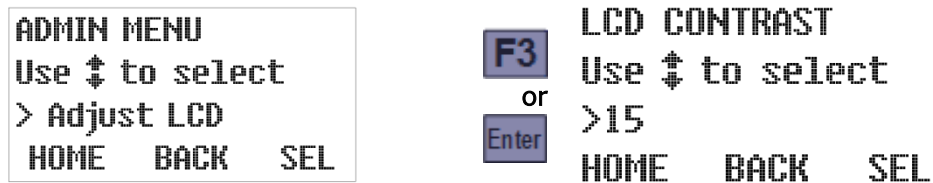

- Pressing the Up or Down key will increment or decrement that setting while making the screen slightly brighter or darker. The darkest possible setting is 0, the brightest is 30:



- Pressing the SEL [F3] or Enter key saves the displayed setting and displays the next Administration Menu option.



3.2.4: Archival Data Administration

Future firmware versions will record the details of each collected sample in the controller’s internal flash memory. The following as-yet-unimplemented Administration Menu options will then copy that data to USB-connected memory devices and then optionally erase it:

- Download Archive
- Clear Archive

3.2.5: Set ID Number

Each sampler can be assigned a unique ID number that will be included in its archival data files and used to identify it via its serial communication channels. To set it:

1. Select the [Administration Menu](#) (see page 22), use the Up key to scroll to its Set ID option, and then press the SEL [F3] or Enter key to display the current ID:

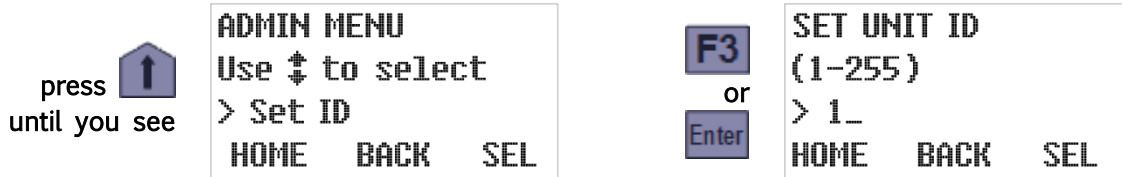

2. Type the new ID by pressing the corresponding numeric keys, then press the SEL [F3] or Enter key to save it and advance to the next Administration Menu option:



3.2.6: Set Volumetric Units

Each sampler can be configured on-the-fly to display flow volumes and composite bottle sizes in either English or metric units (e.g., gallons or liters). To do so:

1. Select the [Administration Menu](#) (see page 22), use the Up key to scroll to its Set Units option, and then press the SEL [F3] or Enter key to display the currently selected option:

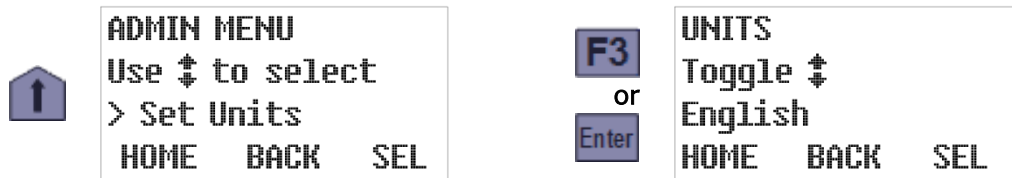

2. Press the Up or Down key to toggle to this option's alternate value. Then press the SEL [F3] or Enter key to save the displayed setting and advance to the next Administration Menu option:



Chapter 4: Sampling Program Configuration

The user interface panel's **Program Menu** is used to configure the **Sampling Programs** (see Appendix A:) and specify which one is selected to be configured and/or started. Although you can directly view and change individual parameters in each program's set, the menu is designed so that all parameters for each program can be set in one continuous process:

- Each program's parameters are divided into several configuration groups.
- Selecting a specific program displays the first parameter in its first group.
- Pressing the SEL [F3] or Enter key (whether or not you have changed the displayed value) displays the next parameter in the same group.
- Options that are rendered inapplicable by those you have already set are not displayed.
- Setting the last parameter in any group returns you to the Program Configuration menu with the next parameter group selected.

In other words, simply access the Program Menu, select the program you want to configure, and then keep pressing the SEL [F3] or Enter key as you verify or change each setting.

4.1: Program Selection

Access the **Main Menu** by pressing the MENU [F3] key and (if so prompted) entering the optional password (see **Menu System** on page 20). The **Program Menu** should be the first Main Menu option—if not, use the Up or Down key to scroll to that option. Then press the SEL [F3] or Enter key to display the Program Select screen:

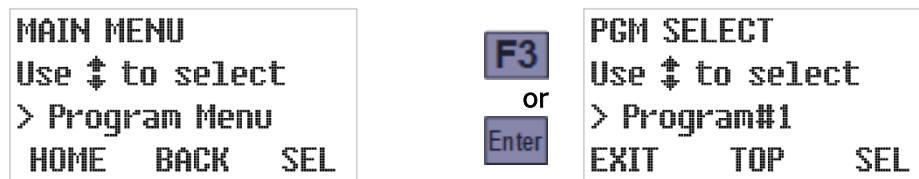

Use the Up or Down key to scroll to the program you want, then press the SEL [F3] or Enter key to select it and display the Program Configuration menu.

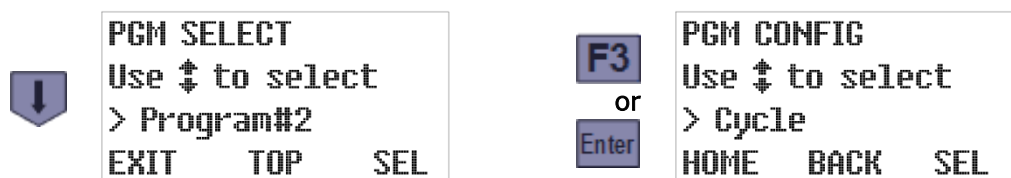

If that program has already been configured and you are just selecting it to be run, press HOME [F1] twice (or BACK [F2] or the Back key three times) to return to the Ready screen:



Otherwise, you can configure the selected program by setting the parameters in each of its five **configuration groups** (see next section).

4.2: Program Configuration Groups

The configuration parameters for each program are divided into five groups:

- [Sampling Cycle Settings](#) (see page 29)
- [Sampling Intervals](#) (see page 33)
- [Bottle Options](#) (see page 41)
- [Run Options](#) (see page 42)
- [Program Events](#) (see page 47)

To access a particular group, select the program you want to configure (see above) to display its Program Configuration menu. Use the Up or Down key to scroll to the parameter group of interest, then press the SEL [F3] or Enter key to display that group's first setting:

↓	<pre>PGM CONFIG Use ↑↓ to select >Cycle HOME BACK SEL</pre>	F3 or Enter	<pre>PREPURGE (0-99 sec.) > 15_ HOME BACK SEL</pre>
↓	<pre>PGM CONFIG Use ↑↓ to select >Smpl. Interval HOME BACK SEL</pre>	F3 or Enter	<pre>SMPL. INTERVAL Use ↑↓ to select >Time HOME BACK SEL</pre>
↓	<pre>PGM CONFIG Use ↑↓ to select >Bottle Opts. HOME BACK SEL</pre>	F3 or Enter	<pre>SAMPLE TYPE Use ↑↓ to select >Composite HOME BACK SEL</pre>
↓	<pre>PGM CONFIG Use ↑↓ to select >Pgm. Run Opts. HOME BACK SEL</pre>	F3 or Enter	<pre>AUTO RERUN Toggle ↑↓ >Enable HOME BACK SEL</pre>
↓	<pre>PGM CONFIG Use ↑↓ to select >Pgm. Events HOME BACK SEL</pre>	F3 or Enter	<pre>PGM EVENT #1 Use ↑↓ to select >End List HOME BACK SEL</pre>

You can return to the Program Configuration menu from any parameter screen by pressing the HOME [F1] key, and then to the Program Selection screen by pressing the BACK [F2] key:

F1	<pre>PGM CONFIG Use ↑↓ to select >Cycle HOME BACK SEL</pre>	F2	<pre>PGM SELECT Use ↑↓ to select > Program#1 EXIT TOP SEL</pre>
-----------	--	-----------	--

4.3: Sampling Cycle Settings

This group includes the parameters that configure the [sampling cycle](#) (see page 59):

- [pre-sampling purge duration](#) (see page 29)
- [sample size](#) (see page 30)
- [post-sampling purge duration](#) (see page 30)
- [line conditioning rinses](#) (see page 31)
- [incomplete sample recycling](#) (see page 32)
- [consecutive sampling](#) (see page 32)

To access those parameters, [select the program](#) you want to configure (see page 27) and press the SEL [F3] or Enter key to display its first parameter group (Cycle). Then press the SEL [F3] or Enter key again to display that group's first setting:

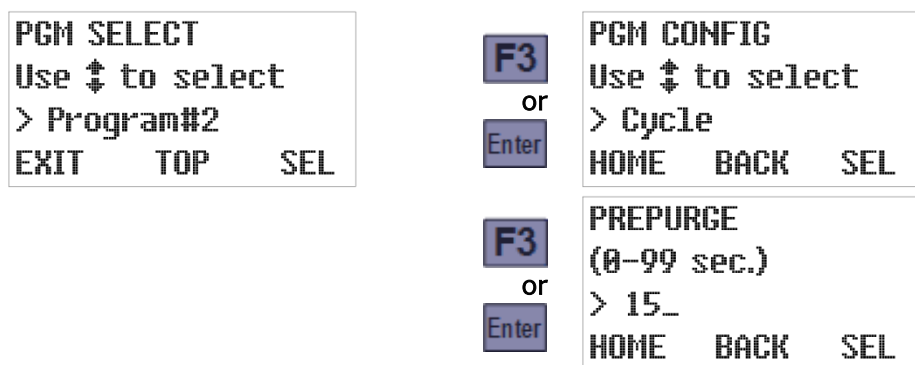

4.3.1: Pre-Sampling Purge Duration

This parameter specifies the number of seconds the chamber will be pressurized to clear the sampling tube prior to drawing a sample. To determine and optionally change its value:

1. Select the Cycle parameter group to display this parameter's current value (see above).
2. If desired, type a new prepurge duration by pressing the corresponding numeric keys. When you type the first digit, the old value is erased and the F1 prompt changes from HOME to UNDO. You can then press the UNDO [F1] key to start over, or the BACK [F2] or Back key to delete the most-recently typed digit.
3. Press the SEL [F3] or Enter key to save the displayed value (changed or not) and advance to the next Sampling Cycle group parameter.

To change the prepurge duration to 20 seconds, for example:



4.3.2: Sample Size

This parameter specifies the intended size of each sample in milliliters/grams. To determine and optionally change its value:

1. Accept or change the Prepurge Duration, which will display this parameter's current value.
2. If desired, type a new sample size by pressing the corresponding numeric keys. When you type the first digit, the old value is erased and the F1 prompt changes from HOME to UNDO. You can then press the UNDO [F1] key to start over, or the BACK [F2] or Back key to delete the most-recently typed digit.
3. Press the SEL [F3] or Enter key to save the displayed value (changed or not) and advance to the next Sampling Cycle group parameter.

To change the sample size to 100 ml, for example:



If the new sample size triggers an automatic reduction in the configured number of [samples per bottle](#) (see page 41), the following screen will briefly appear:

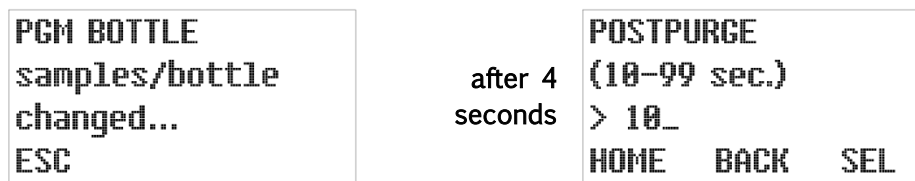

4.3.3: Post-Sampling Purge Duration

This parameter specifies the number of seconds the chamber will be pressurized after each sample is drawn, in order to reverse the fluid flow and clear the sampling tube prior to weighing the samples. To determine and optionally change its value:



1. Accept or change the Sample Size, which will display this parameter's current value.
2. If desired, type a new postpurge duration by pressing the corresponding numeric keys. When you type the first digit, the old value will be erased and the F1 prompt will change from HOME to UNDO. You can then press the UNDO [F1] key to start over, or the BACK [F2] or Back key to delete the most-recently typed digit.
3. Press the SEL [F3] or Enter key to save the displayed value (changed or not) and advance to the next Sampling Cycle group parameter.

4.3.4: Line Conditioning Rinses

This feature can be configured to rinse out the intake line up to four times prior to drawing each sample. To enable it, specify a non-zero number of rinses and then set its pressure and vacuum phase durations:

1. View/change the Postpurge Duration and then press the SEL [F3] or Enter key to display the currently-specified number of rinses (see above).
2. Type the desired value by pressing the corresponding numeric key. Then press the SEL [F3] or Enter key to save the displayed number of rinses:
 - Setting it to 0 disables this feature, in which case the screens for setting its pressure and vacuum phase durations will not be displayed:



- Setting it to any other value would display the current pressure phase duration:



3. Type the new pressure time by pressing the corresponding numeric keys. Then press the SEL [F3] or Enter key to save the displayed pressure time and display the current vacuum phase duration:

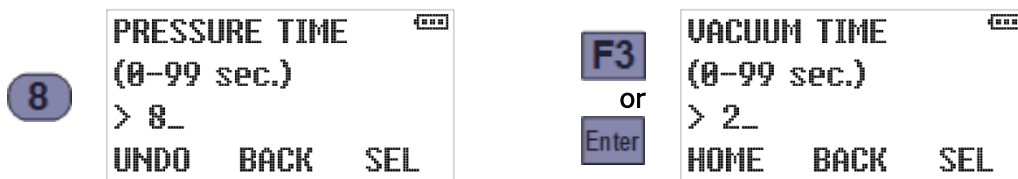

4. Type the new vacuum time by pressing the corresponding numeric keys. Then press the SEL [F3] or Enter key to save the displayed vacuum time and advance to the next Sampling Cycle group parameter:



⚠ The vacuum phase should be brief enough that no water is drawn into the sampling chamber. If it was, it would limit the minimum size of the sample and might even result in the chamber overflowing into the pump.

4.3.5: Incomplete Sample Recycling

If this feature is enabled, the controller will “recycle” the collection of incomplete (less than 60 percent of the configured size) samples by repeating the sampling cycle (except for initializing and zeroing the load cell) as many as four times. To enable or disable it:

1. View/change the rinse settings and then press the SEL [F3] or Enter key to display the current status of this feature.
2. You can enable this feature by pressing the 1 key, disable it by pressing the 0 key, or toggle its status by pressing the TGL [F2], Up or Down key.
3. Press the SEL [F3] or Enter key to save the displayed status and advance to the next Sampling Cycle group parameter.



4.3.6: Consecutive Sampling

This parameter specifies the number of samples to be drawn at the end of each time or flow interval. If you set it to more than one, the full sampling cycle (including recycling if needed) will be repeated the specified number of times for each interval.

You might want to specify more than one and configure appropriate [bottle options](#) (see page 41) for either of two reasons:

- Drawing several samples one after the other and discharging them to the same container effectively allows you to collect samples larger than the 900 ml maximum size.
- Drawing consecutive samples and discharging them to different containers allows you to save and process duplicate samples for verification purposes.

To view/change the number of samples to be drawn per interval:

1. View/change the recycling settings and then press the SEL [F3] or Enter key to display the current value of this parameter.
2. Type the new value by pressing the corresponding numeric keys. Then press the SEL [F3] or Enter key to save the displayed value and return to the Program Configuration menu scrolled to the next parameter group.

To configure a sample to draw two samples per interval, for example:



4.4: Sampling Intervals

This group includes one main parameter that specifies the type of sampling interval(s) the controller will use, and several parameter groups that configure those interval(s).

To directly access the sampling interval type, [select the program](#) you want to configure (see page 27), then press the Down key to scroll to the Sample Intervals group:

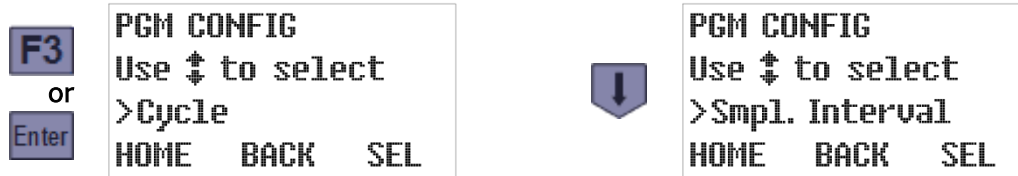

Press the SEL [F3] or Enter key to display the currently-configured interval type, then use the Down or Up key to scroll to the desired new setting. With that value displayed, press the SEL [F3] or Enter key to display the first parameter for that interval type:

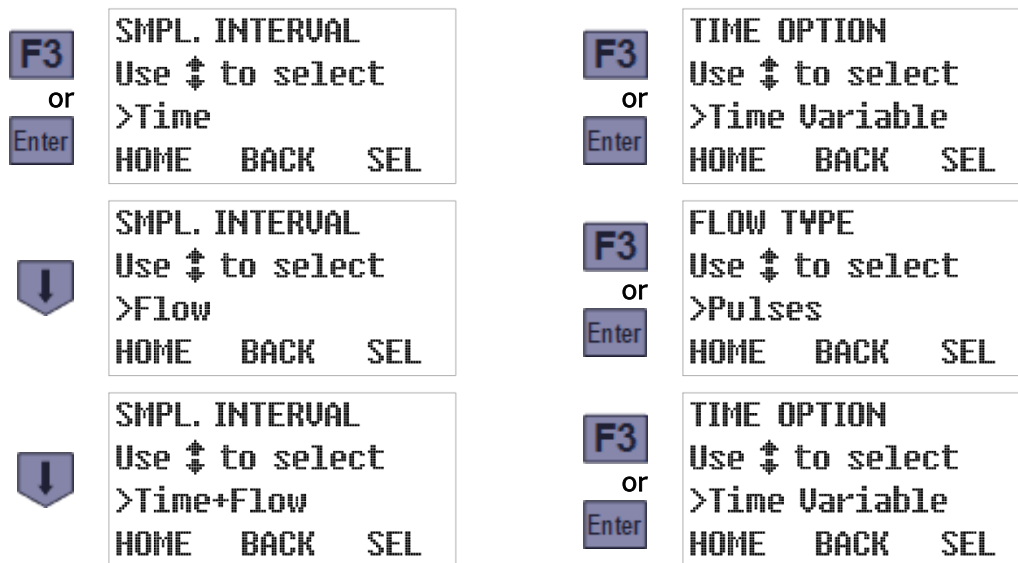

4.4.1: Timed Interval Sampling

Selecting the **Time** sampling interval option configures the controller to wait a specified number of minutes after initiating one sample before initiating the next:

- If the samples are to be drawn at regular intervals, select the **Time Fixed** option and then set the fixed length of those intervals. For example, you might configure a program to draw samples every 60 minutes until it is stopped.
- Otherwise, select the **Time Variable** option and then specify no more than 24 time intervals. One sample will be drawn at the end of each specified interval, after which the last interval will be repeated until the program is stopped. For example, you might configure a program to draw its first sample an hour after starting and then switch to 30 minute intervals.

To select the desired option:

1. Scroll the Sample Interval parameter's value to Time (see above), then press the SEL [F3] or Enter key to save that value and display the currently-selected Time Option:

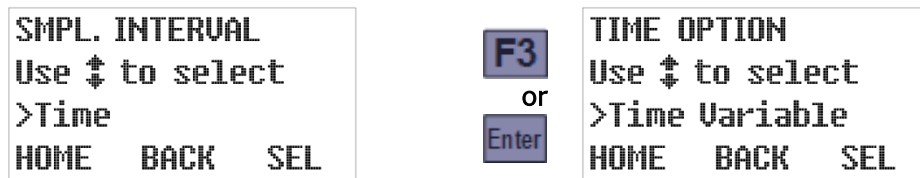

2. Use the Up or Down key to toggle between that parameter's two possible values, then press the SEL [F3] or Enter key to save the displayed value and display its first setting:

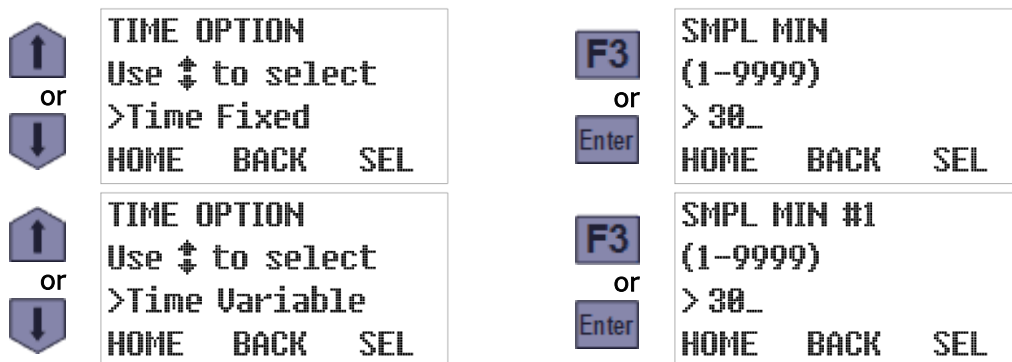

4.4.1.1: Fixed Length Time Intervals

As shown above, selecting the **Time Fixed** option displays its first (and only) parameter—the length of time it waits between initiating any sample and the next. To change it, type the new duration (20 minutes, for example) by pressing the corresponding numeric keys. Then press the SEL [F3] or Enter key to save the displayed Sample Minutes (changed or not) and display the Program Configuration menu's Bottle Options screen:



4.4.1.2: Variable Length Time Intervals

As shown previously, selecting the **Time Variable** option displays the first of 24 Sample Minutes parameters—the length of time it will wait before drawing its first sample. To change its value, type the new duration (20 minutes, for example) by pressing the corresponding numeric keys. Press the SEL [F3] or Enter key to save that value (changed or not) and display the next:

<p>2 0</p>	<p>SMPL MIN #1 (1-9999) > 20_ UNDO BACK SEL</p>	<p>F3 or Enter</p>	<p>SMPL MIN #2 (0-9999)0-end > 60_ HOME BACK SEL</p>
------------	--	----------------------------	---

The digit keys can then be used to change the number of minutes the program would wait between initiating its first and second samples. Pressing the SEL [F3] or Enter key would again save the displayed value and display the next. And so on until pressing the SEL [F3] or Enter key while Sample Minutes #24 is displayed restores the Program Configuration menu scrolled to its next group (Bottle Options).

<p>6 0</p>	<p>SMPL MIN #24 (1-9999)0-end > 60_ UNDO BACK SEL</p>	<p>F3 or Enter</p>	<p>PGM CONFIG Use ↑ to select > Bottle Opts. HOME BACK SEL</p>
------------	--	----------------------------	---

However, you do not need to set all 24 intervals—setting any one of them to 0 configures the program to use the value of the preceding parameter for all subsequent intervals. For example, setting Sample Minutes #5 to 120 and Sample Minutes #6 to 0 would have the same effect as setting Sample Minutes #6 through #24 all to 120 (the value of Sample Minutes #5):

<p>1 2 0</p>	<p>SMPL MIN #5 (0-9999)0-end > 120_ UNDO BACK SEL</p>	<p>F3 or Enter</p>	<p>SMPL MIN #6 (0-9999)0-end > 150_ HOME BACK SEL</p>
<p>0</p>	<p>SMPL MIN #6 (0-9999)0-end > 0_ UNDO BACK SEL</p>	<p>F3 or Enter</p>	<p>PGM CONFIG Use ↑ to select > Bottle Opts. HOME BACK SEL</p>

4.4.2: Flow Interval Sampling

Selecting the **Flow** sampling interval option configures the controller to initiate sampling as its accumulated flow measurement increases by specified volumes. You must then:

- Select the flow input type (4-20 mA, 0-5 Vdc, 0-10 Vdc, or discrete pulse).
- Specify the flow rate corresponding to the maximum signal (analog input only).
- Specify the incremental flow between the initiation of one sample and the next:
 - If the samples are to be drawn at regular intervals (for example, after each 5000 gallon flow increment), select the **Flow Fixed** option and set the fixed length of those intervals.
 - Otherwise, select the **Flow Variable** option and specify no more than 24 flow intervals. One sample will be drawn at the end of each specified interval, after which the last interval will be repeated until the program is stopped. For example, you might configure a program to draw its first sample when the total flow reaches 5000 gallons, and then switch to 2500 gallon intervals (i.e., after 7500, 10000 and so on total gallons).

Flow volumes are specified in either gallons or liters, depending on the current Administration Menu **Units Setting** (see page 26).

To **specify the input type**, scroll the Sample Interval parameter's value to Flow, then press the SEL [F3] or Enter key to save that value and display the currently-selected Flow Type:

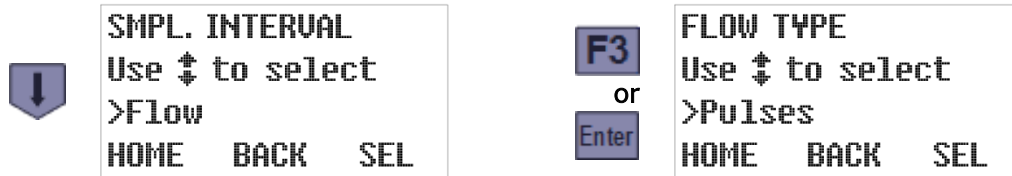

Use the Up or Down key to scroll to the desired type, then press the SEL [F3] or Enter key to save it and display its first setting:

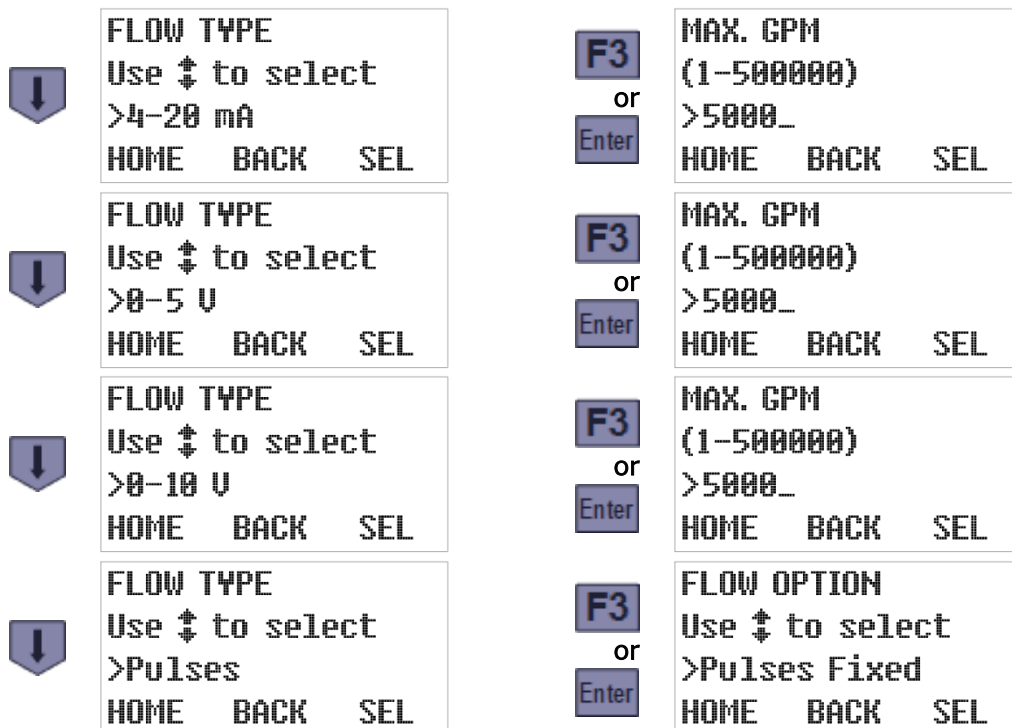

4.4.2.1: Analog Flow Input

If you select one of the analog inputs types (4-20 mA, 0-5 Vdc, or 0-10 Vdc), samples will be initiated an integer number of gallons apart. Thus, you must specify the flow rate (in gallons per minute) corresponding to the transmitter's maximum signal, after which you can specify the sampling intervals in gallons:

1. Select the flow input type (as described above) to display the current maximum flow rate setting (the rate at which the transmitter would transmit its maximum signal). This example shows the 0-10 Vdc option, but the resulting screen would be the same for the 0-5 Vdc or 4-20 mA options as well:

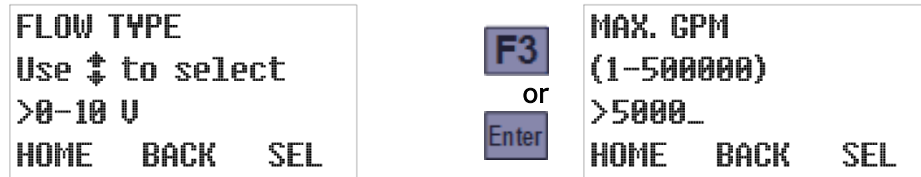

2. To change that setting, type a new maximum flow rate by pressing the corresponding numeric keys. When you type the first digit, the old value will be erased and the F1 prompt will change from HOME to UNDO. You can then press the UNDO [F1] key to start over, or the BACK [F2] or Back key to delete the most-recently typed digit.
3. Press the SEL [F3] or Enter key to save the displayed value (changed or not) and display the current flow option (fixed or variable sampling intervals). As an example:



The above example assumes you are using a flow transmitter whose signal varies from 0 Vdc at no flow up to 10 Vdc at 1500 gallons per minute. A 1.0 Vdc signal would then indicate the flow was 150 gpm, so the controller would then calculate the instantaneous flow by multiplying 150 by the input signal in volts.

4. Use the Up or Down key to toggle between the Flow Option's two possible values, then press the SEL [F3] or Enter key to save the displayed value and display its first setting:

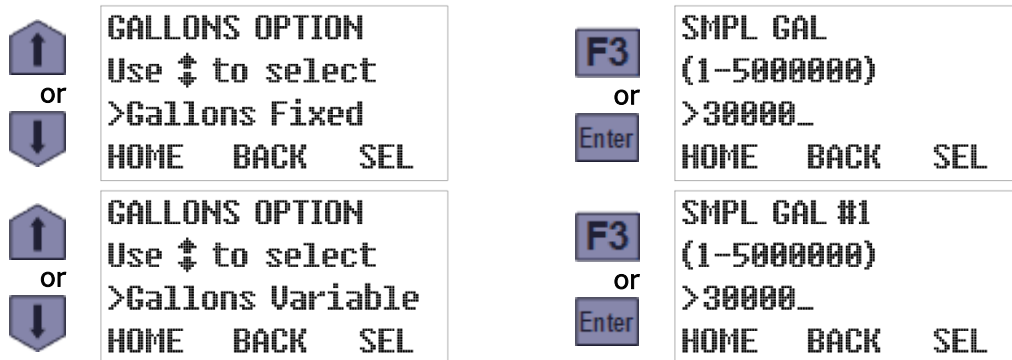

4.4.2.1.1: Fixed Volume Flow Intervals

As shown previously, selecting the **Flow Fixed** option displays its only parameter—the specified change in flow between samples. To change that interval, type a new value by pressing the corresponding numeric keys. Then press the SEL [F3] or Enter key to save the displayed Sample Gallons (changed or not) and display the Program Configuration menu’s next screen:



4.4.2.1.2: Variable Volume Flow Intervals

As shown previously, selecting the **Flow Variable** option displays the first of 24 Sample Gallons parameters—the incremental flow at which the controller will draw its first sample. To change it, type the new flow increment (2400 gallons, for example) by pressing the corresponding numeric keys. Press the SEL [F3] or Enter key to save that value (changed or not) and display the next:



The digit keys can then be used to change the number of gallons the program would measure between initiating its first and second samples. Pressing the SEL [F3] or Enter key would again save the displayed value and display the next. And so on until pressing the SEL [F3] or Enter key while Sample Gallons #24 is displayed restores the Program Configuration menu scrolled to its next group (Bottle Options):



However, you do not need to set all 24 intervals—setting any one of them to 0 configures the program to use the value of the preceding parameter for all subsequent intervals. For example, setting Sample Gallons #5 to 4000 and Sample Gallons #6 to 0 would have the same effect as setting Sample Gallons #6 through #24 all to 4000 (the value of Sample Gallons #5):

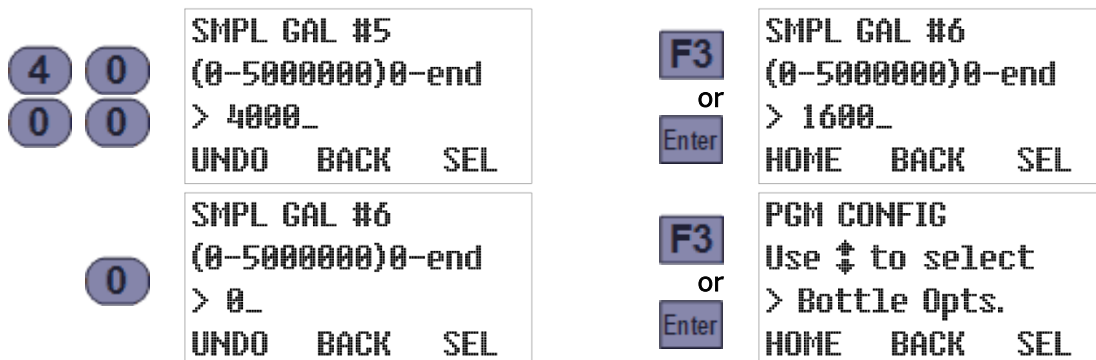

4.4.2.2: Pulsing Flow Input

The pulse flow type is for meters that transmit discrete pulses at specific flow intervals. For example, a meter that sends one pulse for every 100 gallons of flow will transmit its first pulse when the total flow it has measured reaches 100 gallons, a second at 200 gallons, and so on.

When this flow type is selected, you must configure the controller to draw samples at intervals that are an integer number of pulses apart (which correspond to the flow increments at which you really want it to draw samples):

1. Select the **pulse flow type** (see page 36) to display the current value of the flow option (fixed or variable intervals):

```
FLOW TYPE
Use ↑↓ to select
>Pulses
HOME  BACK  SEL
```

F3
or
Enter

```
FLOW OPTION
Use ↑↓ to select
>Pulses Variable
HOME  BACK  SEL
```

2. Use the Up or Down key to toggle between that parameter's two possible values, then press the SEL [F3] or Enter key to save the displayed value and display its first setting:

↑
or
↓

```
FLOW OPTION
Use ↑↓ to select
>Pulses Fixed
HOME  BACK  SEL
```

F3
or
Enter

```
SMPL PULSES
(1-9999)
>320_
HOME  BACK  SEL
```

↑
or
↓

```
FLOW OPTION
Use ↑↓ to select
>Pulses Variable
HOME  BACK  SEL
```

F3
or
Enter

```
SMPL PULSES #1
(1-9999)
>320_
HOME  BACK  SEL
```

4.4.2.2.1: Fixed Pulses Flow Intervals

As shown above, selecting the **Pulses Fixed** option displays its only parameter—the specified number of input pulses between samples. To change that setting, type the new interval pulse count (240, for example) by pressing the corresponding numeric keys. Then press the SEL [F3] or Enter key to save the displayed Sample Pulses (changed or not) and display the Program Configuration menu's next screen:

2 4
0

```
SMPL PULSES
(1-9999)
>320_
HOME  BACK  SEL
```

F3
or
Enter

```
PGM CONFIG
Use ↑↓ to select
> Bottle Opts.
HOME  BACK  SEL
```

You can repurpose the flow-pulse input to initiate a sample each time a connected PLC or other external device closes its circuit (see page 72). In that case, you would of course set this parameter to 1.

4.4.2.2.2: Variable Pulses Flow Intervals

Selecting the **Pulses Variable** option displays the first of 24 Sample Pulses parameters—the number of pulses at which the controller will draw its first sample. To change it, type the new first sample pulse count (240, for example) by pressing the corresponding numeric keys. Press the SEL [F3] or Enter key to save that value (changed or not) and display the next:



The digit keys can then be used to change the number of pulses the program would wait between initiating its first and second samples. Pressing the SEL [F3] or Enter key would again save the displayed value and display the next. And so on until pressing the SEL [F3] or Enter key while Sample Pulses #24 is displayed restores the Program Configuration menu scrolled to its next group (Bottle Options):

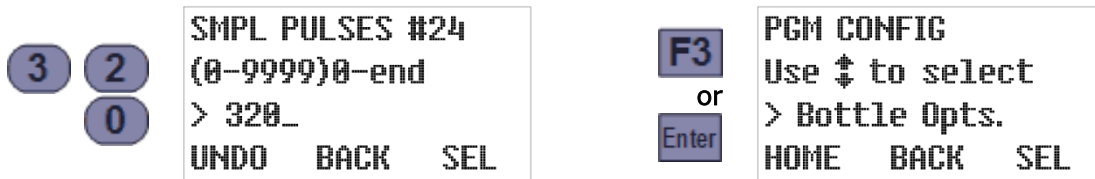

However, you do not need to set all 24 intervals—setting any one of them to 0 configures the program to use the value of the preceding parameter for all subsequent intervals. For example, setting Sample Pulses #5 to 400 and Sample Pulses #6 to 0 would have the same effect as setting Sample Pulses #6 through #24 all to 400 (the value of Sample Pulses #5):

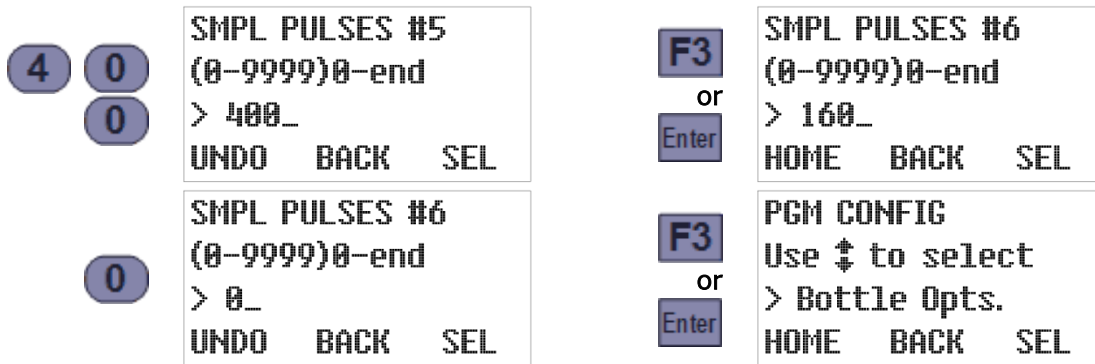

4.4.3: Time+Flow Interval Sampling

Selecting the **Time+Flow** sampling interval option configures the controller to draw samples at either time or flow intervals, whichever proves to be the soonest for each sample. In other words, it accumulates both the time and the flow since the last sample was initiated, and initiates the next (and resets both counters) as soon as either reaches its configured target.

When this option is selected, you will be prompted to:

1. select the **Time Option** and set its associated parameters (see page 34), and then
2. select the **Flow Type and Option** and set their associated parameters (see page 36).

4.5: Bottle Options

This group includes one main parameter that specifies which type of [sample containers](#) your sampler has (see page 13), and a set of parameters for each possible type. To directly access that main parameter, [select the program](#) you want to configure (see page 27), then press the Down key twice to scroll to the Bottle Options group:

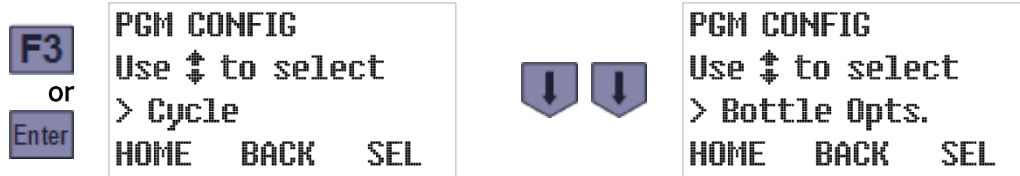

Press the SEL [F3] or Enter key to display the currently-selected storage type. For Wall-Mount Samplers, this will always be Composite and cannot be changed. Pressing the SEL [F3] or Enter key will then display the currently-configured container size:



That size will be shown in either liters or gallons, depending on the current Administration Menu [Units Setting](#) (see page 26). Use the Up or Down key to scroll to the container size you are using, then press the SEL [F3] or Enter key to save that setting and display the number of samples that container is currently set to receive (note that the maximum is calculated by dividing 90 percent of the container volume by the previously-set sample size):

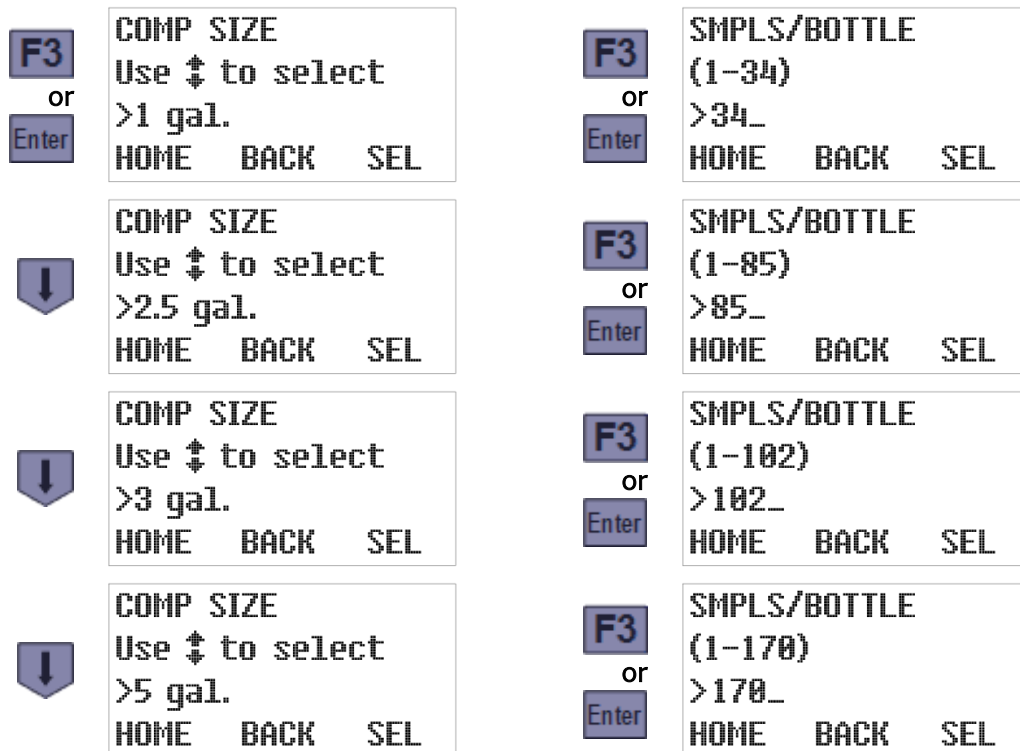

The digit keys can then be used to change the number of samples the program will discharge to the container before automatically stopping itself. Pressing the SEL [F3] or Enter key will save the displayed value and display the Program Configuration menu with its next group selected:



 This setting might be automatically reduced if you subsequently select a smaller container or increase the configured sample size.

4.6: Program Run Options

This group includes the parameters that configure the following features:

- [automatic rerun](#) (see page 43)
- [delayed starting](#) (see page 43)
- [float enable](#) (see page 44)
- [fault enable](#) (see page 44)
- [timed stop](#) (see page 45)
- [bottle limit override](#) (see page 46)

To directly access those parameters, [select the program](#) you want to configure (see page 27):

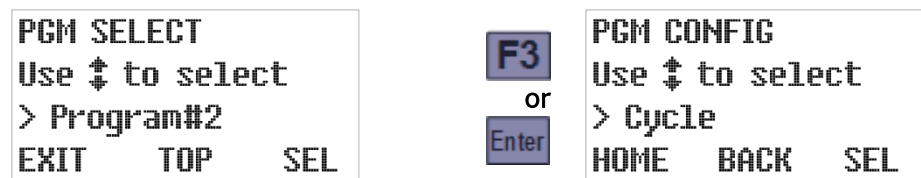

Press the Up key twice to scroll to the Program Configuration menu's Run Options group, then press the SEL [F3] or Enter key again to display that group's first setting:



4.6.1: Automatic Rerun

By default, the sampling program must be manually reset each time it stops, which indicates to the controller that the sample containers have been emptied. If you configure a [Start Event](#) (see page 47) to repeatedly start and stop the sampler, enabling the Automatic Rerun parameter as well would enable the program to restart without being reset.

⚠ You should not enable this parameter unless you are scheduling automatic start events.

To view and optionally change this setting:

1. Select the Run Options group to display this parameter's current value (see above).
2. If desired, press the Up or Down key to toggle it on or off, then press the SEL [F3] or Enter key to save the displayed value (changed or not) and advance to the next Run Options group parameter.



4.6.2: Delayed Start

By default, starting a sampling program will immediately initiate its interval timers. If it is set up to draw samples at one hour intervals, for example, the first will be taken one hour after the program is started. You can configure it to wait longer than that by setting a non-zero start delay. Other methods of delaying the first sample are to use the Float Enable parameter (see below), schedule regular automatic [Start Events](#) (see page 47), or manually set up one-time [Timed Starts](#) (see page 54).

To view and optionally change this setting:

1. Accept or change the Auto Rerun setting, which will display this parameter's current value.
2. If desired, type a new delay duration by pressing the corresponding numeric keys. When you type the first digit, the old value is erased and the F1 prompt changes from HOME to UNDO. You can then press the UNDO [F1] key to start over, or the BACK [F2] or Back key to delete the most-recently typed digit.
3. Press the SEL [F3] or Enter key to save the displayed value (changed or not) and advance to the next Run Option group parameter.

To change the start delay to 360 minutes, for example:



4.6.3: Fault Option

This parameter specifies whether the [alarm relay](#) (see page 70) should energize when the sampling program is waiting to be reset (whether it completed normally, was manually stopped, or detected a fatal fault) or is continuing to run despite have detected a non-fatal fault.

To view and optionally change this setting:

1. Accept or change the Float Option setting, which will display this parameter's current value.
2. If desired, press the Up or Down key to toggle it on or off, then press the SEL [F3] or Enter key to save the displayed value (changed or not) and advance to the next Run Options group parameter:

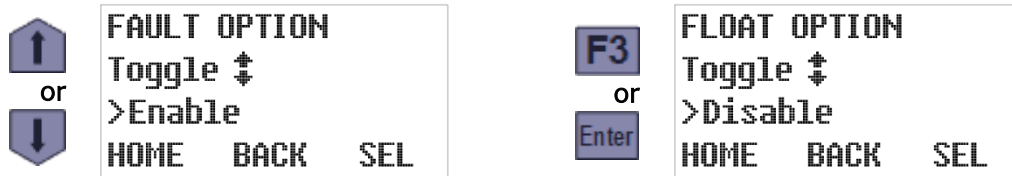

4.6.4: Float Option

This parameter configures the program to suspend sampling until its [float input](#) circuit is closed and subsequently either continue or pause sampling if it reopens (see page 71).

To view and optionally change its value:

1. Accept or change the Delay Start setting, which will display this parameter's current value.
2. If desired, press the Up or Down key to toggle it on or off, then press the SEL [F3] or Enter key to save the displayed value (changed or not) and advance to the next Run Options group parameter.



4.6.5: Timed Stop

This parameter configures the program to automatically stop a specified number of hours or minutes after it initiates its interval timers. To view and optionally change its value:

1. Accept or change the Fault Option setting, which will display this parameter's current value.
2. If desired, press the Up or Down key to scroll to the desired value, then press the SEL [F3] or Enter key to save that value (changed or not). Selecting any option other than Custom will save that value and display the next Run Option parameter's current value:

The image shows a sequence of five terminal screens for the 'TIMED STOP' parameter. Each screen has a downward arrow icon to its left. The screens display the following text:

- Screen 1: **TIMED STOP**
Use ↑↓ to select
> None
HOME BACK SEL
- Screen 2: **TIMED STOP**
Use ↑↓ to select
> 24 Hour
HOME BACK SEL
- Screen 3: **TIMED STOP**
Use ↑↓ to select
> 12 Hour
HOME BACK SEL
- Screen 4: **TIMED STOP**
Use ↑↓ to select
> 8 Hour
HOME BACK SEL
- Screen 5: **TIMED STOP**
Use ↑↓ to select
> Custom
HOME BACK SEL

To the right of these screens are two more terminal screens:

- Screen 6: **PGM CONFIG**
Use ↑↓ to select
> Pgm. Events
HOME BACK SEL
- Screen 7: **STOP TIME**
(0-9999 min.)
> 0_
HOME BACK SEL

Navigation is indicated by a box containing 'F3' or 'Enter' with an arrow pointing to the right, and another box containing 'F3' or 'Enter' with an arrow pointing down.

Selecting the Custom option displays a screen for setting the number of minutes the program will run before automatically stopping. The digit keys can then be used to change that setting, and pressing the SEL [F3] or Enter key will save the displayed value and display the next Run Option parameter's current value:

The image shows two terminal screens:

- Screen 1: **STOP TIME**
(0-9999 min.)
> 960_
UNDO BACK SEL
- Screen 2: **BOTTLE LIMIT**
Toggle ↑↓
> Pgm Stop
HOME BACK SEL

Navigation is indicated by a box containing 'F3' or 'Enter' with an arrow pointing to the right, and another box containing 'F3' or 'Enter' with an arrow pointing down. The digit keys 9, 6, and 0 are shown in circles to the left of the 'STOP TIME' screen.

4.6.6: Bottle Limit Override

Each program's **Bottle Options** (see page 41) configure it to stop after discharging a specific number of samples into its composite sample container, provided this parameter has its default "Program Stop" value. If you would prefer that the unit continue drawing samples indefinitely, without keeping track of how full the sample container is, you should instead set this parameter to "Program Continue":

1. Accept or change the Stop Time setting, which will display this parameter's current value.
2. If desired, press the Up or Down key to toggle between its two possible values, then press the SEL [F3] or Enter key to save the displayed value (changed or not) and return to the Program Configuration menu.



4.7: Program Events

Each program's [scheduled events](#) (see page 79) are defined by a list that can be accessed via the **Program Events** group. Each event on that list has three associated values:

- the type of event (start, stop, pause, halt, resume or manually sample),
- the days of the week on which the event will be executed, and
- the time of day on those days at which the event will be initiated.

Events are consecutively numbered as they are defined, so the event numbers shown when you review the list do not indicate the order in which those events will be executed. You cannot directly access a particular event's settings, add a new event without reviewing those already on the list, or delete an event without deleting all higher numbered events as well. But you can disable an existing event (by setting it to execute on no days of the week), or replace it by changing any or all of its three settings (type, days and/or time).

4.7.1: Reviewing Scheduled Events

When you access the Program Events group, it will initially display the event type for the first event on the list (which will be **End List** if there are none). Repeatedly pressing the Enter key will then display the remaining settings for that event, followed by the settings for the second event, and so on until you reach the first undefined event (whose type will be End List).

To review the event schedule:

1. Select the [program](#) you want to schedule events for (see page 27):



2. Press the Up key to scroll to the Program Events group, then press SEL [F3] or the Enter key to display the type of the first scheduled event (**Start Time** in the example below):



3. Press the Enter key to view that event's days setting, and again to view its time setting:



The second line of the WEEKDAYS screen displays seven letters representing the days of the week, while the third displays bullets indicating the days (if any) on which the event will occur—Monday through Friday in the example to the left above.

Similarly, the second line of the EVENT TIME screen displays the program’s 24-hour time (a.k.a. military) time format while its third line indicates the time on those days at which this event will be initiated—2:00 PM (1400 hours) in the example to the right above.

4. Continue pressing the Enter key repeatedly to review each event in turn. You can also re-examine previously-viewed screens by repeatedly pressing the Back key.
5. After you have reviewed the last listed event, the readout will indicate you have reached an event assigned the End List type. You can then press the Event key again to return to the Program Configuration menu, or add a new event to the end of the list (see below).

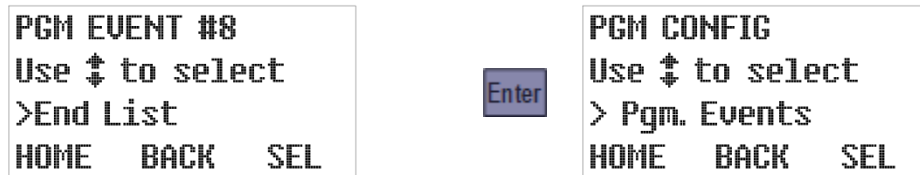

4.7.2: Adding and Editing Events

Entirely new events can only be added to the end of the list, by changing the placeholder **End List** event that is displayed after you review the last existing event (see above). However, you might be able to effectively add a new one by editing a **disabled event** (see page 51). *In either case, there is no procedural difference between adding and editing an event.*

1. Navigate to the **Program Events** group and access its End List event as described above:

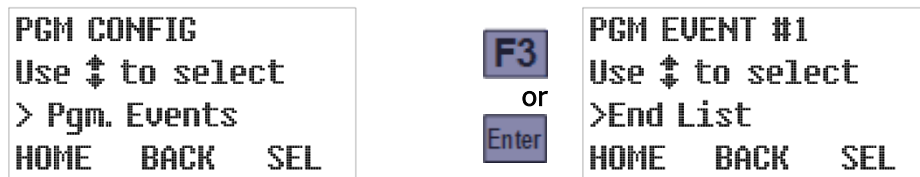

This example assumes no events have yet been set up. If any have, you must review them (see above) in order to access the End List event. While doing so, you can verify that the event has not been set up previously and make sure it would not be better to create it by rescheduling or otherwise editing an existing event.

2. Use the Up or Down key to scroll to the desired event type (Start Time, for example), then press SEL [F3] or the Enter key to save that selection and display the Weekdays screen:

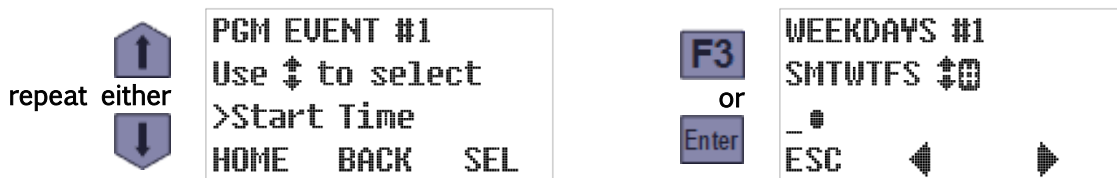

3. The third line includes an underline cursor that can be moved to a different day by pressing the Previous [F2] or Next [F3] key:



- Pressing the Up or Down key will toggle execution on the cursor-selected weekday on or off, as indicated by the arrows prompt at the end of the second line:

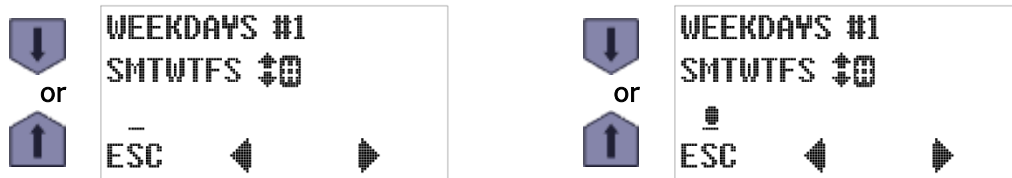

- You can schedule an event to occur on a specific set of days by pressing the 7 (all days), 0 (no days), 2 (Saturday and Sunday only), or 5 (Monday through Friday) key—as hinted by the hash tag/number sign prompt at the end of the second line:

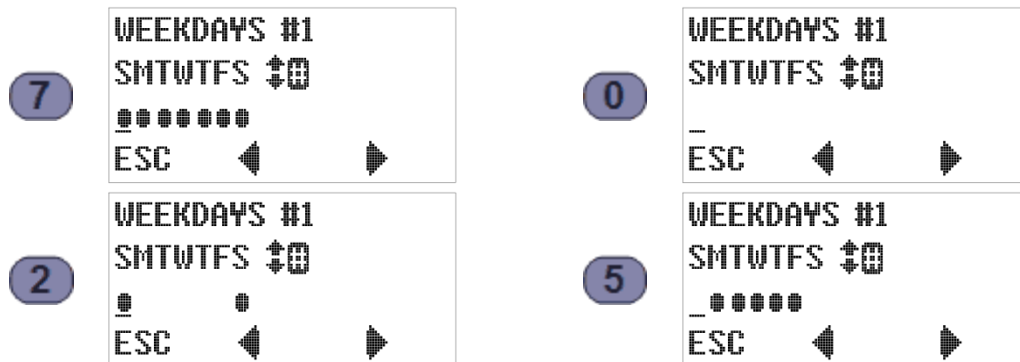

- Pressing the ESC [F1] key cancels any change(s) you have tentatively made to this setting (but not any changes made to the current event's other settings) and restores the parent Program Event screen. For example:



- Pressing the Enter key saves the weekdays setting and displays the Event Time screen:

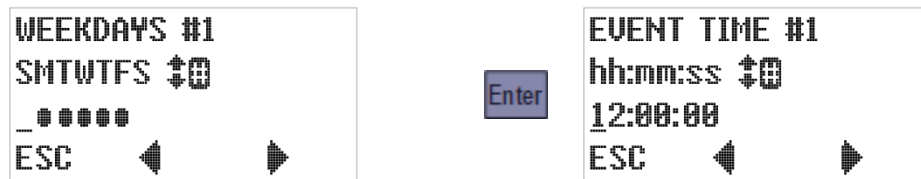

Again, an underline cursor indicates the digit currently subject to editing:

- Press the Previous [F2] or Next [F3] key to move that cursor one digit left or right.
 - Press any appropriate numeric key to set the current digit and advance the cursor, OR press the Up or Down key to increment or decrement the current digit (either action is recognized only if a valid time results).
 - Press the ESC [F1] key to undo any change to the displayed time and return to the Weekdays screen.
- Pressing the Enter key saves the indicated time setting and displays the first screen for the next Program.

4.7.3: Deleting Events

Events can be deleted only from the end of the list—by reviewing the settings for each event you want to keep and then changing the type of the first one you want to delete to **End List**.

⚠ An event could effectively be removed from the middle of the list by disabling it, as described in the next topic.

For example, if there were eight listed events and you wanted to delete all but the first two:

1. Access the **Program Events** group as described above:

<pre>PGM CONFIG Use ↓ to select > Pgm. Events HOME BACK SEL</pre>	<p>F3 or Enter</p>	<pre>PGM EVENT #1 Use ↓ to select > Start Time HOME BACK SEL</pre>
--	--	---

2. Press the Enter key repeatedly until the first Event #3 screen appears, then use the Up or Down key to scroll to the End List event type:

<p>Enter repeat until</p>	<pre>PGM EVENT #3 Use ↓ to select >Stop Time HOME BACK SEL</pre>	<p>repeat either</p> <p>↑ or ↓</p>	<pre>PGM EVENT #3 Use ↓ to select >End List HOME BACK SEL</pre>
--------------------------------------	---	--	--

3. Finally, press SEL [F3] or the Enter key to delete this and any higher-numbered events:

<p>F3 or Enter</p>	<pre>PGM CONFIG Use ↓ to select > Pgm. Events HOME BACK SEL</pre>
--	--

4.7.4: Disabling Events

You can disable an event without deleting it (so you could later re-enable it), or effectively delete an event from the middle of the list, by configuring it to occur on no days of the week. For example, if there are four or more defined events but you no longer want the third one to execute:

1. Access the **Program Events** group as previously described:

```
PGM CONFIG
Use ↑↓ to select
> Pgm. Events
HOME  BACK  SEL
```

F3
or
Enter

```
PGM EVENT #1
Use ↑↓ to select
> Start Time
HOME  BACK  SEL
```

2. Press the Enter key repeatedly until the first Event #3 screen appears. The displayed event type will be irrelevant once the event has been disabled, so you need only press SEL [F3] or the Enter key to display its WEEKDAYS screen:

Enter
repeat until

```
PGM EVENT #3
Use ↑↓ to select
>Stop Time
HOME  BACK  SEL
```

F3
or
Enter

```
WEEKDAYS #3
SMTWTFS ↑↓
●●●●●●
ESC  ←  →
```

3. Press the 0 (zero) key to deselect all days of the week, then press the Enter key to save that change and display the event's execution time:

0

```
WEEKDAYS #3
SMTWTFS ↑↓
_
ESC  ←  →
```

Enter

```
EVENT TIME #3
hh:mm:ss ↑↓
12:00:00
ESC  ←  →
```

4. The time setting will also be irrelevant given that execution has been disabled for every weekday. So you need only press the Enter key to display the next event's type screen, from which you can exit the Program Events group by pressing HOME [F1]:

Enter

```
PGM EVENT #4
Use ↑↓ to select
>Pause Program
HOME  BACK  SEL
```

F1

```
PGM CONFIG
Use ↑↓ to select
> Pgm. Events
HOME  BACK  SEL
```

Chapter 5: Sampler Operation

Although a QLS Wall Mount Sampler requires little or no operator intervention (see page 9), its user interface panel can be used to:

- select a different sampling program (see page 27)
- start the indicated program (see page 54)
- monitor the program while it is running (see page 57)
- manually collect unscheduled samples (see page 61)
- pause and resume sample collection (see page 61)
- stop and reset the sampling program (see page 63)

That interface (see below) is mounted in the upper housing’s top panel and consists of a keypad and a four-line LCD readout:

- The readout’s top line identifies the selected program and displays its operating state.
- Its second and third lines display sets of status information you can cycle through by pressing the Up or Down keys to the right of the readout.
- Its bottom line indicates the functions of the F1, F2 and F3 keys.

In addition, any of the icons listed in Table 5-1 might be displayed along its right edge.

Table 5-1: User Interface Panel and Icons

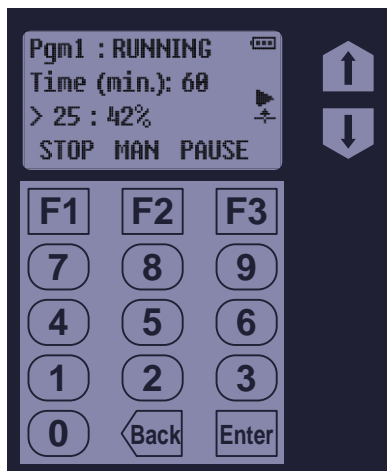



 program is running (see page 57)



 program is paused (see page 61)

 program will automatically start at a specific time (see pages 56 and 55)

 program will automatically stop at a specified time (see page 63)

 sampling cycle is being repeated (see page 60)

 non-fatal faults (see page 54)

 or  arrow up: float switch is closed
arrow down: float switch is open (see pages 55 and 62)

 or  or  power supply voltage level

5.1: Ready State

The LCD's top line identifies the selected program and its operating state, which is "READY" while it is waiting to be started. The second and third lines display sets of additional information you can scroll through using the Up and Down keys:

If set for Time+Flow intervals, the elapsed Time and Gallons or Time and Pulses will be shown. If not, only one of them will.

```
Pgm1 : READY
Time (min.): 60
> 0 : 0%
RUN TIMED MENU
```

Program 1 is set to sample at timed intervals. The first one will be drawn 60 minutes after the program is started.

```
Pgm1 : READY
Gallons : 2500
> 0 : 0%
RUN TIMED MENU
```

Program 1 is set to sample at flow meter volume intervals. The first one will be drawn 2500 gallons after the program is started.

```
Pgm1 : READY
Pulses : 600
> 0 : 0%
RUN TIMED MENU
```

Program 1 is set to sample at flow meter pulse intervals. The first one will be drawn 600 pulses after the program is started.



```
Pgm1 : READY
Smp1:#1
12:34:56 07/08/15
RUN TIMED MENU
```

The next sample drawn will be the first. The current time is 12:34:56. The current date is July 8, 2015.



```
Pgm1 : READY
Comp: 5 gal.
Smp1#: 0 of 168
RUN TIMED MENU
```

Program 1 is set to discharge 168 samples into a 5 gallon container.

When the program is waiting to be started:

- Pressing the RUN [F1] button starts it immediately.
- Pressing the TIMED [F2] button allows you to set the date and time at which it will start.
- Pressing the MENU [F3] key will activate the menu system, from which you could select a [different program](#) (see page 27).

The Alarm Relay (if enabled) is energized if the program is waiting to be reset after completing normally or being manually stopped, or if the float input circuit is enabled and open.

5.2: Sampler Conditions

The approximate control system power supply voltage is always indicated by a battery icon in the upper right corner of the user interface readout.

In addition, a fault icon will be displayed if any of the following conditions exists:

- sampling has been suspended because the float input circuit is open; or
- the most recent sample cycle failed to collect the programmed size sample.

Those conditions will also energize the Alarm Relay (if enabled), which is also energized when the program is waiting to be reset after completing normally or being manually stopped.

5.3: Starting the Selected Program

When the control system is in its Ready state:

- Pressing the RUN [F1] key starts the selected sampling program immediately. However, it might not begin sampling until a time delay elapses, a bottle-full or stream-level float switch is closed, or a scheduled time arrives.
- Pressing the TIMED [F2] key allows you to set a timer that starts that program at a specified time and date (see [Timed-Delay Starting](#) below). Any configured time or float-input delay would further delay the first sampling interval.
- Pressing the MENU [F3] key will activate the [menu system](#) (see 20). You could then select a different program using the [Program Menu](#) (see page 27), although you might first need to enter the [administration password](#) (see page 20).

5.3.1: Timed-Delay Starting

The interval counter(s) will not start until the start delay (if non-zero) has elapsed. In the meantime, the operating state will display as DELAYED and the first information screen will indicate the progress of that delay:

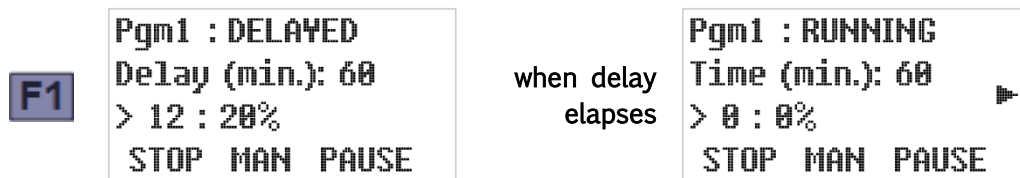

5.3.2: Float-Delayed Starting

If the **float input** is enabled (see page 44), the sampling program will not start its interval counter(s) until the **float-switch circuit** is closed (see page 71). Those counter(s) will remain at zero as long as the float icon points down and start accumulating when it points up (think of this icon as a thumbs-up or thumbs-down indicator):

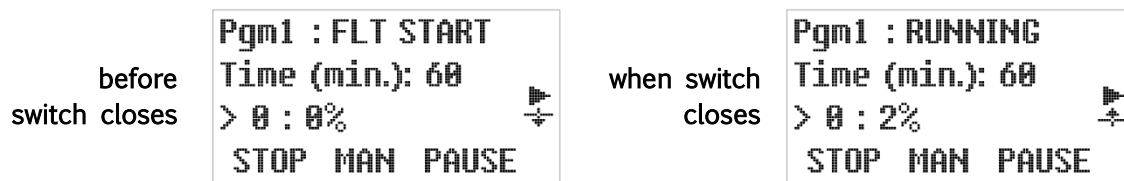

Depending on which of the Factory Menu float input options is enabled, the sampler will subsequently either continue or **suspend sampling** (see page 62) if the float-switch circuit subsequently reopens.

5.3.3: Timed Starting

The selected program can also be started by pressing the TIMED [F2] key, which displays the first of two screens from which you specify the date and time at which you want it to start:



That screen initially displays today's date. Leave it unchanged or:

- Press the Previous [F2] or Next [F3] key to move the underline cursor (which initially selects the first digit of the month for editing) one digit left or right.
- Press the appropriate numeric key to set the selected digit and automatically move the cursor to the right, OR
Press the Up or Down key to increment or decrement that digit, then press the Previous [F2] or Next [F3] key to manually move the cursor.
- Press the ESC [F1] key to cancel the Timed Start and return to the Ready state screen.

Once the desired start date has been set, press the Enter key to save it and display the screen for specifying the time of day at which the program should start. That screen initially shows the current time, which can be changed using the same methods as the date. Use F2 and F3 to select a digit you want to change, then press the Up or Down arrow or a numeric key to change that digit as desired. Finally, press Enter to initiate the TIMED operating state discussed in the following section:



5.3.3.1: Timed State

The Timed operating state is entered when the selected program is:

- set to start at a specified time and day (see previous section), or
- configured to start (or restart) at scheduled times on specified days of every week and then manually started by pressing the RUN [F1] key (see next section).

The run-time screens will then display a clock icon and you can scroll to an additional screen that shows the time and date at which the interval counters will start. The following example of that screen indicates sampling will begin in approximately two days:

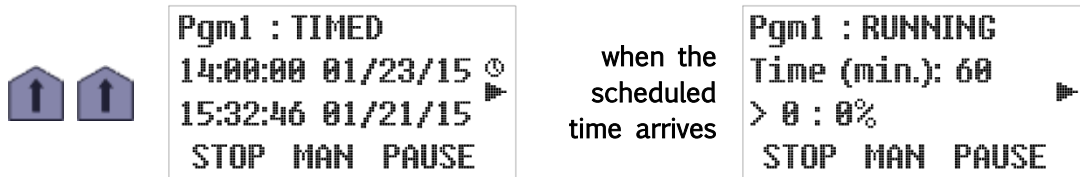

When that time arrives, the program proceeds as if you had just pressed the RUN [F1] key:

5.3.4: Scheduled Starting

Each program can be configured to start (or restart) at scheduled times on specified days of every week. Manually starting such a program will initiate its Timed operating state (see above). When the scheduled time arrives, the program will proceed as if you had just pressed the RUN [F1] key.

When that program completes or is stopped, it will have to be reset before the next start event can restart it unless it is also configured for automatic restarting. If it is, it will instead reset itself and then enter its Auto Rerun state, which is identical to the Timed state described above except the displayed state would be AUTO RERUN instead of TIMED:



When this screen first appears, the sample containers should be replaced with empties.

5.4: Running State

Once the selected program has initiated its sampling-interval counters, the readout's top line displays its operating state as "RUNNING". The second and third lines display scrolling sets of additional information similar to those available in the Ready state:

If set for Time+Flow intervals, the elapsed Time and Gallons or Time and Pulses will be shown. If not, only one of them will.

```
Pgm1 : RUNNING
Time (min.): 60
> 25 : 42%
STOP MAN PAUSE
```

Program 1 is sampling at timed intervals. The next one will be drawn after a 60 minute interval that started 25 minutes ago (42 percent elapsed).

```
Pgm1 : RUNNING
Gallons : 2500
> 1048 : 42%
STOP MAN PAUSE
```

Program 1 is sampling at measured flow intervals. The next one will be drawn after a 2500 gallon interval that started 1048 gallons ago (42 percent elapsed).

```
Pgm1 : RUNNING
Pulses : 600
> 253 : 42%
STOP MAN PAUSE
```

Program 1 is sampling at flow meter pulse intervals. The next one will be drawn after a 600 pulse interval that started 253 pulses ago (42 percent elapsed).

```
Pgm1 : RUNNING
Smp1:#8 : 100 ml
12:34:56 07/08/15
STOP MAN PAUSE
```

Program 1 is drawing 100 ml. samples. The next one will be the eighth (#8). The current time is 12:34:56. The current date is July 8, 2015.



[sample container screens](#) (see page 58)



[start timer](#) (see page 54) or [stop timer](#) (see page 63) screen

When the indicated program is running, the top row keys are assigned the following functions:

- Pressing F1 will immediately [stop the program](#) (see page 63).
- Pressing F2 will immediately trigger the collection of a [manual sample](#) (see page 61).
- Pressing F3 will [pause the sampling](#) (see page 61).

5.4.1: Sampling Intervals

As shown on the previous page, the second and third lines of the primary run-state readout will depend on whether the selected program is configured to draw samples at the end of elapsed time (minutes) or stream flow (gallons or pulses) intervals.

If the program has been configured to sample at the ends of flow intervals with a time limit, both screens will be displayed—you can then use the Up and Down keys to scroll between them. When either interval counter reaches 100 percent, both counters will be reset as an automatic sampling cycle is initiated.

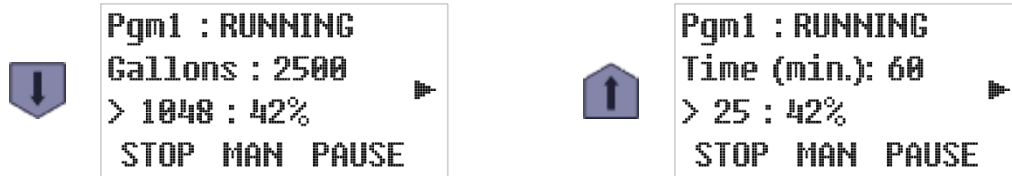

5.4.2: Sample Container Screens

Unless the [No Limit option](#) (see page 63) has been enabled, the controller will keep track of the total volume of wastewater discharged to each sample container and stop if it exceeds 90 percent of the container’s capacity. The following run-state screens indicate which containers are installed and how full they are:

use



and



to alternate

Pgm1 : RUNNING
 Comp: 5 gal.
 > 705 ml : 4%
 STOP MAN PAUSE

The sampler is equipped with a 5 gallon container, into which samples totaling 705 ml have been discharged. So it is about 4 percent full.

Pgm1 : RUNNING
 Comp: 5 gal.
 Smp1#: 7 of 168
 STOP MAN PAUSE

Seven of the 168 samples the program is configured to deposit into that container have been discharged to it so far.

The container size is shown in either liters or gallons, depending on the Administration Menu [Set Units](#) setting (see page 26).

5.4.3: Sampling Cycle

Figure A-2 on page 74 illustrates the full QLS sampling cycle, which can be configured to include up to four optional **line rinse** and an optional **line pre-purge**. When the running program triggers that cycle (or a manual sample is initiated), the optional Run-Status output is set, the displayed state will change to “SAMPLING” and the second and third lines of the readout will report the progress of the sampling cycle (which requires no operator participation):

<pre>SAMPLING loadcell init... sec: 2 STOP</pre>	initialization counts down to zero, then	<pre>SAMPLING loadcell zero... sec: 20 STOP</pre>
--	--	---

The zeroing step determines the sampling chamber’s tare weight. It should take less than the allotted 20 seconds, after which the cycle will advance to its rinse or prepurge phase.

If the sample chamber’s tare weight cannot be determined, the remainder of the current sampling cycle will be skipped and the following screen will be briefly displayed:

<pre>SMPL. ERROR Loadcell Not Zeroed... STOP</pre>	after a few seconds	<pre>Pgm1 : RUNNING Time (min.): 60 > 3 : 5% STOP MAN PAUSE</pre>
--	------------------------	--

Once the load cell has been zeroed, any accumulated water will be blown from the sampling line and strainer by either the first line rinse or the pre-purge:

- If line rinsing is disabled, the program will simply purge the sampling line before suctioning in the intended sample.
- Otherwise, each enabled rinse first blows the line clear and then partially fills it with wastewater. The sample is drawn after the line is purged to complete the final rinse.

as soon as the tare weight is determined	<pre>SAMPLING rinse press... sec: 14 STOP</pre>	these two screens are displayed only if one or more optional rinse cycles have been set up	
followed by	<pre>SAMPLING rinse vac... sec: 10 STOP</pre>		
when the final rinse (if any) is completed	<pre>SAMPLING prepurge... sec: 12 STOP</pre>	prepurge counts down, then sample is drawn	<pre>SAMPLING size: 100 ml. sec: 99 STOP</pre>

The sample is continuously weighed as it is drawn in. When the target weight is reached, the line is again purged and the sample is reweighed:

<p>as soon as the target weight is reached</p>	<pre>SAMPLING postpurge... sec: 25 STOP</pre>	<p>post-purge counts down</p>	<pre>SAMPLING read weight... sec: 4 STOP</pre>
--	---	-----------------------------------	--



After the final weight is recorded, pressure is briefly applied to clear the sampling line. Then the discharge valve is opened to drain the sample to the storage container. The optional Run State output is then cleared and the [run state readouts](#) (see page 57) are restored:

<p>the chamber is slightly pressurized</p>	<pre>SAMPLING read done please wait... STOP</pre>	<p>then the discharge valve opens</p>	<pre>SAMPLING discharge... sec: 12 STOP</pre>
<p>after the discharge step counts down to zero, the running state readouts are restored (the interval counter was restarted when the sample was initiated)</p>			<pre>Pgm1 : RUNNING Time (min.): 60 > 3 : 5% STOP MAN PAUSE</pre>

5.4.3.1: Incomplete Sample Recycling

If a minimum of 60 percent of the intended sample weight is not collected within the allotted 99 seconds, a failed sample error will be indicated:

- If “recycling” is disabled, the error screen is displayed for only a few seconds, after which the line is purged and the incomplete sample is weighed.
- If it is enabled, a recycling icon is displayed while the prepurge and sampling steps are repeated. When the intended weight is reached, or the fourth recycle fails, the line is purged and the sample is weighed.

<p>if the target weight is not reached</p>	<pre>SAMPLING failed sample please wait... STOP</pre>	<p>If recycling is enabled</p>	<pre>SAMPLING failed sample please wait... STOP</pre> <div style="text-align: right; font-size: small;">   </div>
<p>when sample is completed or aborted</p>	<pre>SAMPLING postpurge... sec: 25 STOP</pre>	<p>post-purge counts down</p>	<pre>SAMPLING read weight... sec: 4 STOP</pre>

5.4.3.2: Manual Sampling

Pressing the MAN [F2] key while the selected program is running will trigger the immediate collection of an unscheduled sample using the configured sampling cycle discussed above:

<pre>Pgm1 : RUNNING Time (min.): 60 > 25 : 42% STOP MAN PAUSE</pre>	<div style="background-color: #4a69bd; color: white; padding: 2px 8px; font-weight: bold;">F2</div>	<pre>SAMPLING loadcell init... sec: 2 STOP</pre>
--	---	--

That sample will be counted toward the number of samples the program is configured to put into the sample container. If that fills it the sampling program will be stopped.

If an automatic sample would otherwise have been triggered during the manual cycle, the following screen will be briefly displayed:

```
SMPL. INTERVAL
Sample Blocked
>Wait
ESC
```

Blocked samples ARE NOT DRAWN when the manual sample is completed.

5.5: Paused and Halted States

If you press the PAUSE [F3] key while a program is running, it will immediately enter its PAUSED state. Programs can also be configured to automatically pause and resume at scheduled times.

While the program is paused, the run icon is replaced by a paused icon. The sampling interval will continue to accumulate, but no samples will be taken until the RUNNING state is restored by pressing the RESUME [F3] key:

interval continues to accumulate	<pre>Pgm1 : RUNNING Time (min.): 60 > 25 : 42% STOP MAN PAUSE</pre>	<div style="background-color: #4a69bd; color: white; padding: 2px 8px; font-weight: bold;">F3</div>	<pre>Pgm1 : PAUSED Time (min.): 60 > 26 : 43% STOP RESUME</pre>
	<pre>Pgm1 : PAUSED Time (min.): 60 > 47 : 78% STOP RESUME</pre>	<div style="background-color: #4a69bd; color: white; padding: 2px 8px; font-weight: bold;">F3</div>	<pre>Pgm1 : RUNNING Time (min.): 60 > 48 : 80% STOP MAN PAUSE</pre>

Programs can also be configured to halt and resume at scheduled times. The resulting Halted state is similar to the Paused state, except that any configured flow intervals will not continue to accumulate.

While the program is halted, the running icon is replaced by a halted icon (as shown below). The Running state is often automatically restored at a scheduled time, but in any case can be manually restored by pressing the RESUME [F3] key:

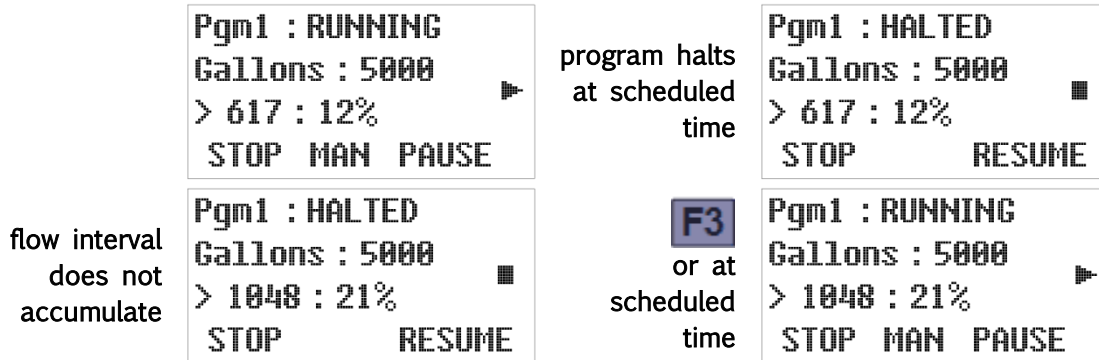

You can stop the program or take manual samples while automatic sampling is paused or halted. If the configured sampling interval reaches 100 percent one or more times, the following screen will briefly appear:

```
SMPL. INTERVAL
Sample Blocked
>Wait
ESC
```

Blocked samples are not drawn when the paused or halted program is resumed.

5.5.1: Float Suspended Sampling

If the [Float Option](#) (see page 44) is enabled and [factory-configured](#) (see page 71) to suspend sampling when that input is cleared, the interval counters are held at zero whenever the float switch is open:

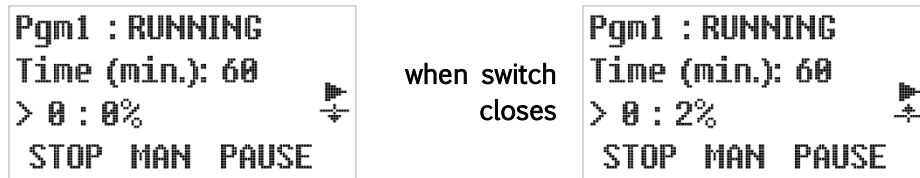

Note that the float icon points down when the float-switch circuit is open (sampling suspended) and up when that circuit is closed (sampling resumed). This can be remembered by thinking of this icon as a thumbs-up or thumbs-down indicator:

- indicates the stream depth is insufficient to sample
- indicates the stream depth is sufficient to sample

5.6: Stopping the Program

The running program might have been set up to take a specific number of samples and then stop, in which case it would then display the following DONE operating state screen:

<pre>Pgm1 : RUNNING Comp: 5 gal. Smp1#: 167 of 168 STOP MAN PAUSE</pre>	<p>when final sample has been drawn</p>	<pre>Pgm1 : DONE >Pgm Complete >Normal RESET</pre>
---	---	--

Alternately, it might have been set to only run for a specified length of time or to stop at a specific, scheduled time. If so, it displays a timed stop icon above the running icon (as shown below) and you can scroll to an added RUNNING screen whose second line shows the time and date at which the program will shut down and display the DONE operating state screen:

	<pre>Pgm1 : RUNNING 18:00:00 07/09/15 12:34:56 07/08/15 STOP MAN PAUSE</pre>	<p>when scheduled time arrives</p>	<pre>Pgm1 : DONE >Pgm Complete >Normal RESET</pre>
---	--	--	--

In either case, the program can be prematurely stopped by pressing the STOP [F1] key, after which it would then display its STOPPED screen:

	<pre>Pgm1 : STOPPED >Pgm Stopped >From Keypad RESET</pre>
---	---

The RESET prompt indicates you cannot restart the program until you press the F1 key to zero its interval and container volume counters and advance it to its READY state.

5.6.1: Continuous Operation

If the [Bottle Limit](#) option (see page 46) is set to “Program Continue”, the program will ignore its samples per bottle setting and continue sampling indefinitely, without requiring anyone to ever press the RESET [F1] key.

As the sampling program has no way of knowing how many samples it has discharged since the container was last emptied, the sample count screen (see page 58) merely indicates “NL” (no limit). However, a composite sampler would still suspend sampling if its bottle-full float switch ever opened, restarting its interval counter(s) when the container was replaced:

<pre>Pgm1 : RUNNING Smp1#:NL 12:34:56 07/08/15 STOP MAN PAUSE</pre>	<p>if composite container filled up</p>	<pre>Pgm1 : RUNNING Time (min.): 60 > 0 : 0% STOP MAN PAUSE</pre>
---	---	--

Chapter 6: Maintenance

QLS Wall Mount Samplers are designed to be nearly maintenance free, but routine cleaning is advisable and some parts might eventually wear out. Due to their compact size, failed units can easily be returned to the factory for repair. Alternately, replacement parts can be ordered using the numbers listed in Appendix B:

6.1: Cleaning the Sampler

You should periodically flush the sample chamber and intake line by drawing several samples from a bucket of warm, soapy water, followed by several more drawn from a bucket of warm rinse water (you might want to set up a special program configuration for this purpose). Replace the tubing and/or chamber if that process fails to remove all significant fouling.

6.2: Compression/Vacuum Pump

QLS Wall Mount Samplers are equipped with continuous-duty, permanently-lubricated, piston air compressor/vacuum pumps that provide long-term consistent sampling with vertical lifts of up to 28 feet. **These pumps need no routine maintenance.** In particular, and unlike the costly to maintain, inconsistent, and unreliable peristaltic pumps used in competing samplers, they do not have flexible internal tubes that frequently wear out and need to be replaced.

The pump and its 4-way solenoid valve are mounted behind the housing's protective partition. If your pump's performance declines unacceptably, replacement pumps and service/rebuild kits (including instructions) can be obtained from QCEC.

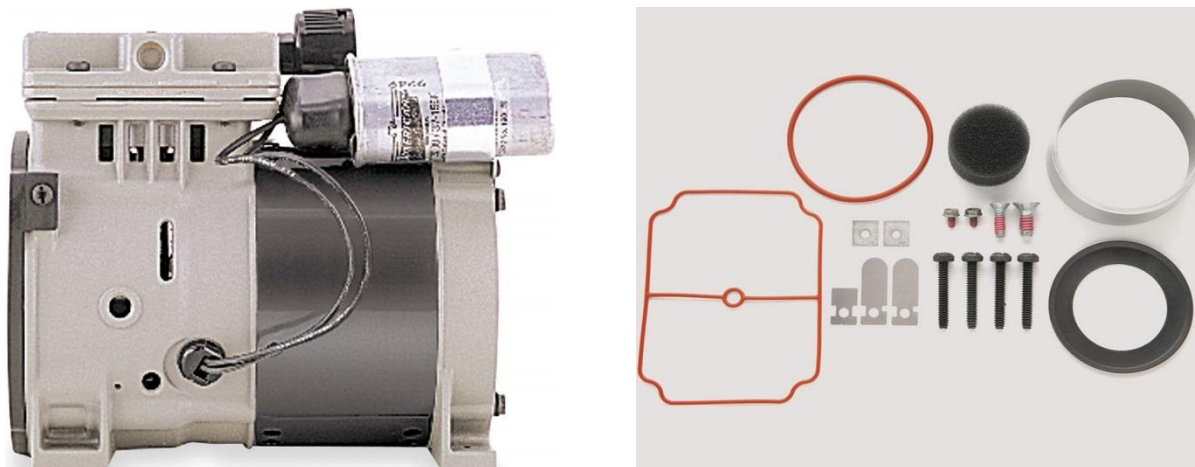

Figure 6-1: QLS Compressor/Vacuum Pump and Service Kit

6.3: Fuse

The sampler's electrical components are protected by a fast-acting, 10A/250 V cartridge fuse whose holder is mounted behind and can be accessed by removing the controller:

- That fuse can be checked and/or replaced by pulling the front cover of that holder forward and down, which automatically ejects the right end of the fuse.
- The control system can be powered down by tipping the top of the holder up to the left.

6.4: Troubleshooting Tips

Use the following suggestions to troubleshoot the listed problems.

1: User interface panel is dark:

- a) Press any key to turn backlight on (it turns off after two minutes of inactivity).
- b) If the screen is still dark but you can make out that it is displaying information, use the Administration Menu to [adjust the backlight](#) (see page 25).
- c) If the screen is uniformly black, make sure the sampler is powered up (you should be able to hear the fan circulating air through the sample compartment).
- d) Check the [control system fuse](#) (see page 64)
- e) Reboot the controller by briefly tripping that fuse or unplugging the sampler.
- f) If the controller is powered but its interface panel is black, the logic board is probably defective—call QCEC for technical assistance.

2: One or more buttons never work:

- a) The logic board is malfunctioning—call QCEC for technical assistance.

3: Readout never changes and cannot be scrolled:

- a) Reboot the controller by briefly unplugging the sampler.
- b) Controller hardware or software is faulty—call QCEC for technical assistance.

4: Readout indicates program will automatically start at midnight, 12/31/99

- a) Stop the selected program and disable its Automatic Rerun parameter.

5: Readout indicates the load cell cannot be initialized:

- a) Check the load cell controller's plug-in connection
- b) Call QCEC for technical assistance.

6: Readout indicates sampling failures—too little (if any) wastewater is collected:

- a) Check the intake strainer and tube for obstructions and make sure the intake strainer is fully submerged.
- b) Make sure the intake line is properly connected to the sampler's intake port. If a compression fitting is used, the ferrule must be properly positioned and the nut properly tightened.
- c) Make sure the pinch valve is energizing and seals the discharge tube when it does.
- d) Make sure the vacuum pump and solenoid are depressurizing the sample chamber.
- e) Check for vacuum line leaks.
- f) Adjust the velocity control valve for more vacuum.

7: Samples are too large—small sample size is consistently exceeded:

- a) Make sure line conditioning rinses are not drawing wastewater into the sample chamber.
- b) Make sure sample chamber empties completely after each sample.
- c) Adjust the velocity-limiting valve (see page 16).

8: Purging does not clear the intake line:

- a) Make sure the pinch valve is energizing and seals the discharge tube when it does.
- b) Check the intake strainer and tube for obstructions.
- c) Make sure the vacuum pump and solenoid are pressurizing the sample chamber.

9: Sampling continues despite full or over-flowing container:

- a) Check the configured container size.
- b) Verify that the No Limit feature is disabled. If you deliberately enabled it, be sure to empty the container before it overflows.

Appendix A: Controller Capabilities

This appendix describes the capabilities of the version 2.0 sample control system firmware, in order to help you decide how best to adapt it to the needs of your sampling application.

A.1: Overview

The control system consists primarily of six **sampling programs** and a **supervisory routine** that executes when the sampler is first powered up and whenever the selected program is stopped.

A.1.1: Supervisory Routine (Ready State)

When the sampler is powered up, the supervisory routine briefly displays the installed firmware version number and revision letter (e.g., Version 2.0 Revision C). It then indicates the controller is Ready to run. While it is operating in that state, the user interface panel can be used to:

- start the selected program immediately,
- start that program, but delay its execution to a specified future date and time-of-day, or
- display its administration and configuration menus, in order to:
 - set the sampler's configuration password and ID number, adjust its real-time clock and display panel, and manage its archival data;
 - select and configure the control program; and
 - set up certain hardware and menu system features (QCEC personnel only).

Once the selected program has been started, the menu system functions are unavailable until it stops (or is stopped)—at which time the controller returns to its supervisory/Ready state.

- ✎ The controller administration and program configuration functions are not available while the sampling program is running.

A.1.2: Menu System Outline

The following outline lists all possible Menu System entries. Those that are actually displayed by any given sampler will depend on its hardware features, purchased options, and values assigned to related Factory and Program Menu parameters.

Main Menu

Program Menu

Program Select parameter (1|2|3|4|5|6)

Program Configuration menu (for selected program)

sampling Cycle group

Prepurge (seconds)

Sample Size (milliliters)

Postpurge (seconds)

Number of Rinses (0 to 4)

if > 0:

Pressure Time (seconds)

Vacuum Time (seconds)

Recycle (Enable/Disable)

Consecutive Samples (1 to 24)

Sample Intervals group

Sample Interval (Time|Flow|Time+Flow)

if Time or Time+Flow:

Time Option (Time Fixed|Time Variable)

if Time Fixed:

Sample Minutes

if Time Variable:

Sample Minutes list

if Flow or Time+Flow:

Flow Type (4-20mA|0-5V|0-10V|Pulses)

if 4-20mA|0-5V|0-10V:

Maximum Gallons [Liters] Per Minute

Gallons {Liters} Option (GallonsFixed|GallonsVariable)
[LitersFixed|LitersVariable]

if Gallons [Liters] Fixed:

Sample Gallons [Liters]

if Gallons {Liters} Variable:

Sample Gallons [Liters] list

if Pulses:

Flow Option (PulsesFixed|PulsesVariable)

if Pulses Fixed:

Sample Pulses

if Pulses Variable:

Sample Pulses list

- Bottle Options group
 - Sample Type (Composite)
 - Composite Size (options enabled at factory)
 - Samples per Bottle
- Program Run Options group
 - Automatic Rerun
 - Delay Start (minutes)
 - Float Option (enable/disable)
 - Fault Option (enable/disable)
 - Timed Stop (None|24Hour|12Hour|8Hour|Custom)
 - if Custom:
 - Stop Time (minutes)
- Program Events list
 - for each:
 - Program Event (Start|Stop|Sample|Pause|Halt|Resume)
 - Weekdays
 - Time (of day)
- Administration Menu
 - Set Password
 - Clear Password
 - Set Daylight Savings Time (enable/disable)
 - Set Clock (date & time-of-day)
 - Adjust LCD
 - Download Archive
 - Clear Archive
 - Set ID
 - Set Units (English|Metric)
- Factory Menu (for QCEC personnel only)
- Loadcell Menu (for QCEC personnel only)

A.2: Inputs and Outputs

As shown on the [Electrical Diagram](#) appended to this manual, the sampling controller has the following required and optional inputs and outputs:

- run-status and alarm output relays (see below)
- pump-motor, solenoid-valve and pinch-valve sampling outputs (see below)
- the sample chamber's load-cell controller (see page 71)
- a float-switch input (see page 71)
- one analog and one discrete-pulse flow input (see page 72)

This section tells how the QLS sampling software uses its optional field inputs and outputs.

The QLS Wall Mount Sampler utilizes neither the temperature input nor the turntable inputs and outputs.

A.2.1: Run-Status Output

The controller energizes the power board's run-status relay (thus connecting pins 3 and 4 of the optional field I/O connector) as each sampling cycle is initiated, and de-energizes it as that cycle discharges the sample it collected.

A.2.2: Alarm Output

If the power board's alarm relay is [enabled](#) (see page 44), the controller energizes it (thus connecting pins 5 and 6 of the optional field I/O connector) when:

- sampling has been suspended because the float input circuit is open, as discussed [below](#) (this will also be indicated by displaying a fault icon along the right edge of the screen);
- the most recent sample cycle failed to determine the sampling chamber's tare weight, or failed to collect at least 60 percent of the specified sample volume; or
- the sampling program is waiting to be reset after completing or being manually stopped.

A.2.3: Sampling Outputs

Three electrically-actuated devices control the flow of air and wastewater into and out of the sample chamber (as illustrated above). As shown on the appended [Electrical Diagram](#), each of those devices is controlled by a relay on the controller's power board:

- The Pump relay turns the compressor/vacuum pump motor on at the beginning of each sampling cycle, and off after the collected sample has been discharged.
- The Solenoid relay energizes and de-energizes the four-way solenoid valve that alternately connects the sample chamber to that pump's the vacuum or pressure port.
- The Pinch relay energizes the pinch valve solenoid to seal off the chamber's discharge tube during all but the final (discharge) phase of the sampling cycle. That valve connects to it via a 2-pin CPC in the roof of the sample compartment.

A.2.4: Load Cell Controller

Each sample cycle vacuums wastewater into the sample chamber until its load cell signals that the programmed amount of liquid has been collected, as detailed in the [QLS Sampling Cycle](#) section on page 74. That device has its own control box, mounted in the sample compartment, which attaches to the controller's SDI-12 communication port.

A.2.5: Float Input

The controller provides one internally-powered discrete input that can be connected to an external stream-level float switch. The controller can then be configured (see below) to draw samples only while or after that input circuit has closed. Thus:

- If a stream-level float switch is connected, it should close as the stream level rises above an appropriate minimum level. The sampler could then be configured to draw samples only when the stream depth was sufficient to cover the intake strainer (or above some other appropriate threshold).
- More generally, this is essentially a remote run-permissive input that could be connected to any appropriate field device or PLC relay output.

A.2.5.1: Factory Menu Float Setting

If the [Float Option](#) (see page 44) is enabled and its input circuit is open when the control program is started, the unit will not start drawing samples until the float switch circuit is closed. If that circuit opens after sampling has begun, the program's response will depend on its Factory Menu FLT setting (which is set to your specifications before the unit is shipped):

- If the FLT START/STOP setting is selected, the program will reset its sampling interval counters and not restart them until the float circuit closes again (i.e., those counters will restart from zero when the water level rises high enough to reclose the float switch).
- If the FLT START setting is selected, the program will continue sampling without interruption even if that circuit reopens.

If the FLT OFF setting is selected, the float input is disabled and the Program Menu's FLOAT INPUT parameter is hidden.

A.2.6: Flow Input

The controller provides one analog and one discrete input that are meant for connecting flow meter signals. All Wall-Mount Samplers are equipped with four-pin circular plastic connectors (CPC) that provide terminals for both of those inputs.

Connecting either type of signal allows you to configure [flow interval counters](#) (see page 76) that will initiate samples as the total flow in the sampled stream passes specified volumes. Alternately, the pulse input can be used to remotely trigger the collection of individual samples (see below):

To do that, you must set parameter(s) that specify the connected signal type (4-20 mA, 0-5 VDC, 0-10 VDC, or discrete pulse):

- If an analog flow-rate signal is connected, you must also specify the flow rate (in gallons) corresponding to its maximum value (20 mA, 5 VDC or 10 VDC) and the desired flow intervals in gallons. The controller then integrates that signal to determine the accumulated flow, and draws samples at the specified intervals.
- The discrete signal type is intended to be used with a flow meter that integrates its own flow rate measurement and pulses an output relay on and off at specific accumulated flow intervals. If you connect such an input signal, you need only specify the number of pulses corresponding to the flow intervals at which samples are to be drawn.

Assuming you really want your samples to be drawn at flow volume intervals, you can calculate those counts by dividing the desired flow intervals (in volumetric units) by the incremental flow (in the same units) that triggers each meter relay pulse.

For example, assume the meter pulses its output relay once for every 1000 gallons of stream flow, and you want to sample that stream at 25,000 gallon intervals. You should then set the interval duration to 25 pulses per sample (25000 gallons per sample divided by 1000 gallons per pulse).

A.2.6.1: Remote Sample Initiation

Alternately, you can repurpose the pulse input to initiate a sample each time its circuit is closed by a connected PLC or other external device, effectively allowing such a device to remotely trigger the collection of individual samples.:

1. Select either the Flow or Time+Flow sampling interval option.
2. Set the Flow Type parameter to Pulses.
3. Set the Flow Option parameter to Pulses Fixed.
4. Set the Sample Pulses parameter to 1.

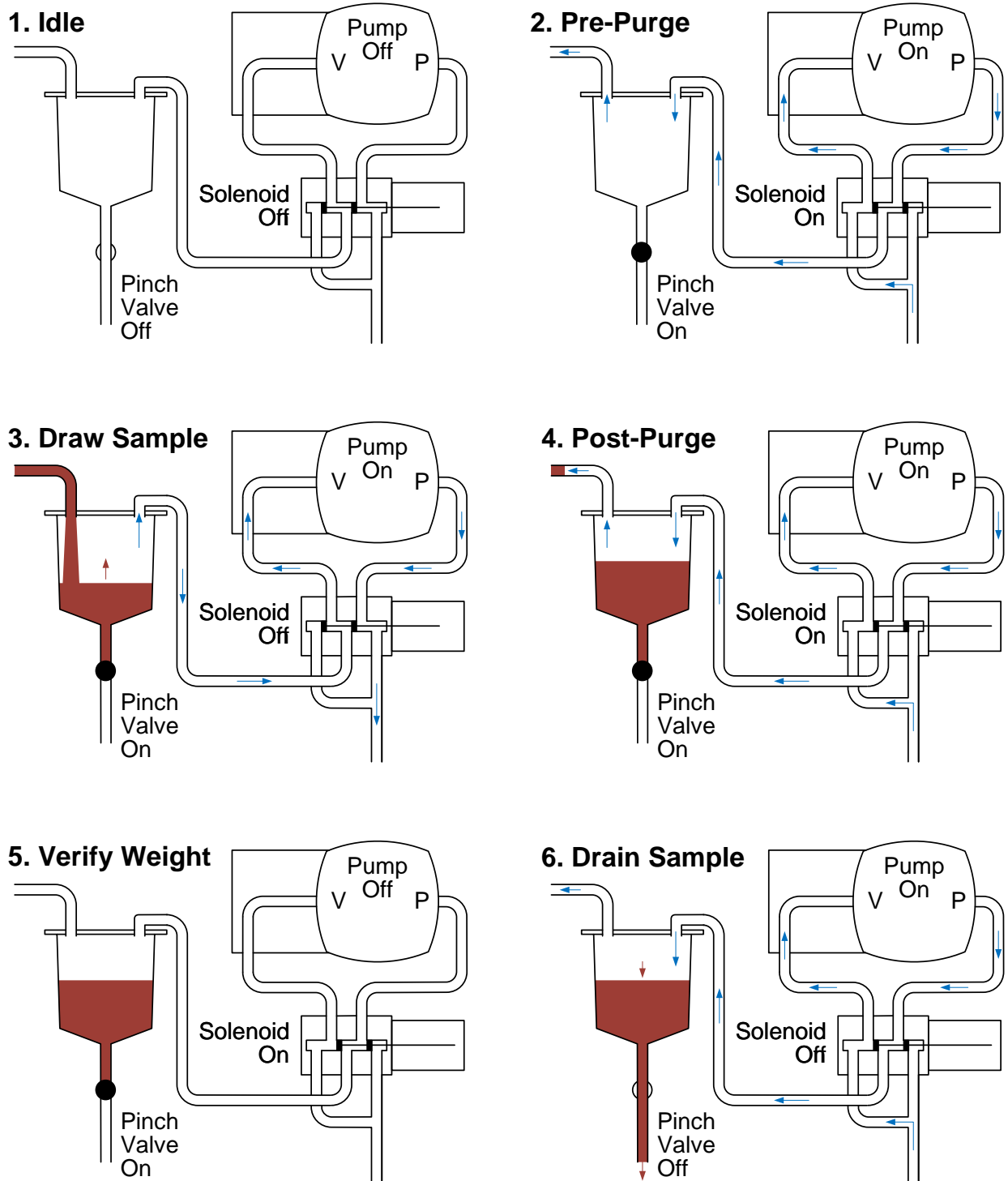

Figure A-1: QLS Flow Sequencing

A.3: Sampling Program

The sampling programs all use the same underlying instructions, but can be configured (via the Program Menu) to provide very different features sets. Each can be set up to:

- draw configurable, fixed-size (20 to 500 milliliters/grams) samples, or sets of consecutive samples, at specified time or flow intervals;
- rinse the sampling line up to four times prior to drawing each sample;
- repeat any sampling cycle up to four times (five total) if needed to collect the specified volume of wastewater;
- delay its execution a specified number of minutes after it is started, or until the optional float input is asserted (or pause and resume repeatedly as that input is set and cleared);
- automatically stop after a configurable amount of time or number of samples; and
- start sampling, pause or halt and later resume, take manual samples and finally stop at scheduled times on specified days of the week, then automatically restart itself if desired.

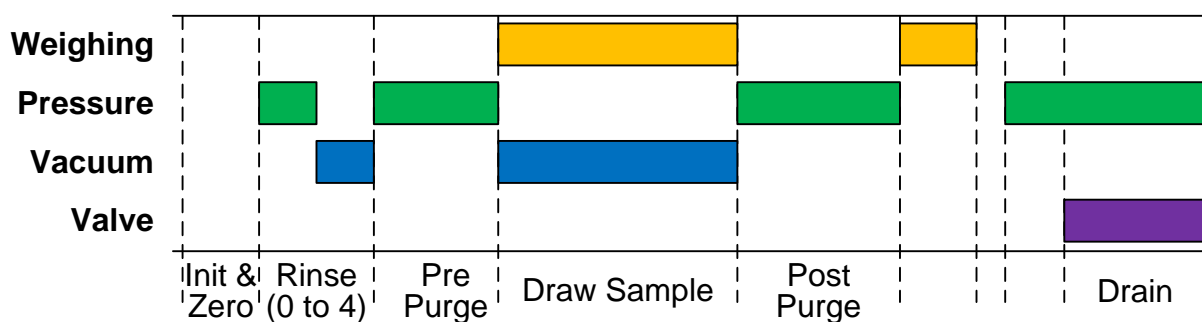

Figure A-2: QLS Sampling Cycle

A.3.1: QLS Sampling Cycle

The figures above and on the preceding page illustrate the full QLS sampling cycle, which can be configured to include up to four optional **rinse** cycles (one is shown) and an optional **prepurge** step (also shown):

1. As each sampling cycle is initiated, the load cell is initialized and the empty chamber is weighed. That tare weight is subtracted from the load cell measurement to zero it.
2. The sampling tube and strainer are optionally rinsed up to four times and then “prepurged” to clear out accumulated water and debris:
 - The prepurge pressurizes the sample chamber for a specified number of seconds, which will presumably clear the intake line. It is rarely disabled.
 - It can be preceded by up to four rinses, each of which first pressurizes the chamber to blow out the line and then sucks a limited amount of water into it. The prepurge phase would then blow out the water drawn in by the last rinse.
3. The chamber is depressurized for up to 100 seconds to draw wastewater into the chamber.

⚠ *When configuring the optional rinse phase, do not make it so long that water is drawn into the sampling chamber. If it was, it would limit the minimum size of the sample and might even result in the chamber overflowing into the pump.*

4. The chamber is “postpurged” for a specified number of seconds to stop the flow and clear at least the portion of the sampling tube that weighs on the load cell, so the sample can be accurately weighed.
5. The weight of the sample is then determined.
6. If [sample recycling](#) (see page 75) is enabled and the sample is more than 40 percent below its intended weight, the above steps will be repeated up to four times.
7. The final weight of the sample is recorded and the cycle is [recalibrated](#) (see page 75).
8. The sample is then discharged by blowing air into the chamber (which will create only a slight positive pressure because the tube has been purged) and then opening the discharge pinch valve.
9. If duplicate sampling has been set up, this procedure immediately repeats the specified number of times.

A.3.1.1: Automatic Calibration

In order to consistently draw samples of the specified size, the sampling cycle automatically recalibrates itself using the following procedure:

1. The sample chamber’s tare weight is determined at the start of each sampling cycle.
2. Each sample is continuously weighed as it is drawn into the chamber.
3. When its net weight equals the configured sample size less a calibration factor calculated from previous samples, the chamber is “postpurged” (i.e., briefly pressurized) to stop the flow as quickly as possible. The weight of the additional wastewater that enters the chamber while the flow is being reversed will ideally equal the calibration factor.
4. The sample is then reweighed and recorded. If it differs from the specified sample size, the calibration factor is recalculated.

The previous sample data this process uses is cleared any time the sample size changes.

A.3.1.2: Sample Recycling

Enabling Recycling configures each sampling cycle to repeat its rinse, prepurge, sample, postpurge and weigh phases up to four times before discharging the accumulated sample if:

- the collected sample does not reach its target weight within the allotted 100 seconds, and
- the final weight is less than 60 percent of the specified sample size.

If the sample was underweight because debris was sucked into and restricted the intake tube, the repeated pre- and post-purging might clear the obstruction and allow the sample to reach its intended weight/volume. If it was underweight because the sampler was sucking air due to an insufficient sampled stream flow, that flow might increase during the recycling process.

In any event, if the final, discharged sample is underweight, a non-fatal fault is indicated and the program keeps running. The fault is cleared the next time a full sample is collected.

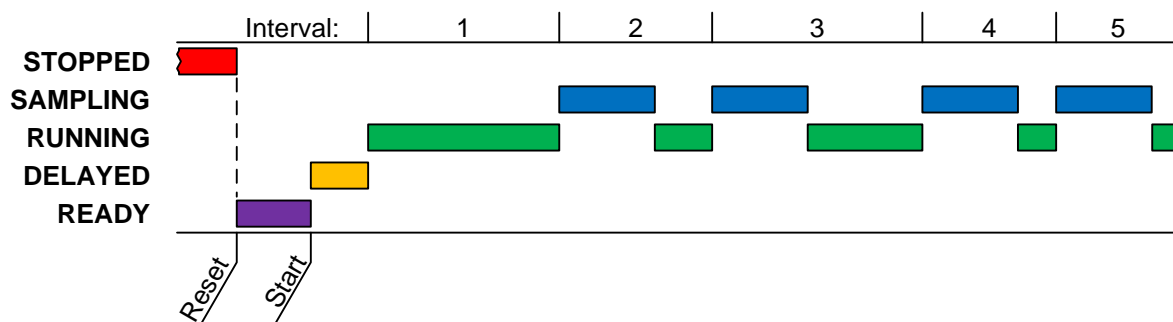

Figure A-3: Basic Sample Timing Diagram

A.3.2: Sampling Intervals

Each program is configured to draw samples in an optionally repeating sequence of up to 24 fixed or variable, time and/or flow-based Sampling Intervals. As shown above, the first interval starts after any [configured delay](#) (see page 77). At the end of that interval, the program simultaneously triggers its first automatic sample and restarts its interval counter(s). And so on.

The durations of time-sampling intervals are specified in minutes. If any flow-sampling options is selected, a suitable [flowmeter](#) must be connected (see page 72) and the interval durations are specified in gallons or flow input pulses (each corresponding to a fixed increment in the total flow measured by the meter):

- When **Time** sampling is chosen, the interval lengths (in minutes) can be fixed or vary in a specified sequence.
- When **Flow** sampling is chosen the interval lengths (in gallons or pulses) can be fixed or vary in a specified sequence,.
- When **Time+Flow** intervals are chosen, both a maximum time and a maximum accumulated flow interval are specified for each sample. Fixed or variable lengths can be independently set for each. For example, you could specify a sequence of variable flow intervals with a fixed maximum time between samples. When the first of each sample's intervals elapses, its sampling cycle is initiated and both interval counters are restarted.

A.3.2.1: Variable Intervals

Selecting Time Variable (or Flow Variable) interval timing allows you to specify a sequence of up to 24 interval durations.

- Each sample is drawn when the corresponding interval elapses, until the program's [stopping criterion](#) is met (see page 78).
- If the specified number of intervals is fewer than the number of samples the program is configured to draw, the last of those intervals will be used for all subsequent samples.

For example, if the program is configured to stop after 750 minutes (12.5 hours), and you configure six alternating 2 and 1 hour intervals (i.e., 2, 1, 2, 1, 2 and 1), the sixth interval would be used for the sixth and all subsequent samples. Thus, samples would be drawn after 2, 3, 5, 6, 8, 9, 10, 11 and 12 hours.

A.3.3: Bottle Options

Each program must be “told” how big its sample container is and how many samples to put into it. This is done by setting the associated **Bottle Options** parameters:

- The Composite Size setting specifies the size of the sample container.
 - The Samples per Bottle setting specifies how many samples will be discharged to that container before the program automatically stops.
- ✎ The maximum number of samples you can specify is limited to 90 percent of the specified container size divided by the Cycle group Sample Size parameter. Increasing the sample size after the Samples per Bottle parameter has been set might automatically reduce the value of the Sample Size parameter.*
- ✎ At least one extra container is usually kept on hand to allow sampling to continue while the filled bottles are readied for reuse.*

In addition, a Wall-Mount Sampler can be configured to collect multiple samples at essentially the same time by assigning the Cycle group’s Consecutive Samples parameter a value greater than one. This would allow you to collect samples larger than the QLS maximum sample size. If the Sample Size is set to 400 and Consecutive Samples is set to 3, for example, a total of 1200 mL (three samples) will be collected each time the interval counter elapses.

A.3.4: Delayed Starting

The selected sampling program can be started by pressing either the START [F1] or TIMED [F2] key while the controller is in its Ready state (i.e., when the supervisory routine is running):

- Pressing START [F1] starts the program immediately.
- Pressing TIMED [F2] prompts you to specify the date and time at which the program will appear to start. Until then, it will operate in a Timed state in which the sampling interval counters do not run but you can initiate manual samples. An additional run-time screen will display the date and time at which the program will “start”, along with the current time and date. When that time comes, the program will proceed as if you had just pressed the RUN [F1] key.

If one or more Program Start [events](#) (see page 79) have been configured, the program will also enter its Timed state when the START [F1] key is pressed. It would then proceed as if you had just pressed the RUN [F1] key when the first scheduled start time arrived.

In either case, the sampling interval counters might be further delayed:

- If the program has been set to wait for a [Float input](#) (see page 71), it will not start its interval counter(s) until that input is asserted. Until then, the program will display its operating state as TIMED.
- If a non-zero value (up to 9999 minutes) has been assigned to the [Delay Start](#) run Option (see page 43), the first sampling interval will be further delayed by that many minutes (see [Figure A-3](#) on page 76). Until then, the program will display its operating state as DELAYED.

A.3.5: Timed Stopping

Once a sampling program has started, it will continue running until it has drawn the number of samples specified by its Bottle Options unless:

- it is stopped by pressing the STOP [F3] key,
- its Timed Stop Run Option (see page 45) has been set to stop it a specified number of hours or minutes after the program was started, or
- Stop Program events have been configured it to stop at configured times on specified days of the week (see next section).

If either a Timed Stop or a Stop Program event has been configured, an additional run-time screen will show the scheduled stop time and all such screens will display a timer icon.

A.3.6: Scheduled Events

Each program can be set to automatically start its interval counters, pause or halt and then resume, initiate manual samples, or stop itself at scheduled times on specified days of the week. As discussed on page 47, those **Program Events** are defined by a variable-length list of parameters, each of which has three associated values:

- the type of event (see table on next page),
- the days of the week on which the event will be executed, and
- the time of day on those days at which the event will be initiated.

Events do not have to be defined in the order they will execute, and can only be added or deleted from the end of the list.

Table A-1: Available Program Event Types

Start Program	The parent program will start automatically if it is ready when the scheduled time is reached on the next scheduled day.
Stop Program	The parent program will stop automatically if it is running when the scheduled time is reached on the next scheduled day. Unless the Auto Rerun option is enabled (see page 43), the program will have to be manually reset before it can be restarted.
Manual Sample	A manual sample will be drawn if the program is running when the scheduled time is reached on the next scheduled day. If a time or flow interval elapses while the manual sample is being drawn, an automatic sample will be drawn as soon as the manual sample cycle has been completed.
Pause Program	Sampling will be suspended if the program is running when the scheduled time is reached on the next scheduled day, but the time and flow interval counters will continue to run. Sampling can be resumed by a Resume Program event, or from the user interface panel. If one or more intervals elapse while the program is paused, only the first such sample will be drawn when the program is resumed.
Halt Program	The interval time and flow counters will be paused if the program is running when the scheduled time is reached on the next scheduled day. Those counters can be resumed (with the accumulated values they had at the time they were halted) by a Resume Program event, or from the user interface panel.
Resume Program	Interval sampling will resume if the program is paused or halted when the scheduled time is reached on the next scheduled day.
End List	Previous event is the last one on the list. Changing an event's type to End List deletes it and all high-numbered events.

Appendix B: Replacement Parts

 Please use current “WW” part numbers when ordering—the obsolete “QL” numbers are provided for cross-reference purposes only.

Table B-1: Electrical System Parts

Part	Part Numbers		Additional Information
Power Cord, 9-foot	WW142	QL-12	14-3 AWG, grounded plug
AC Fuse	WW326	—	fast-acting, 10A/250 V cartridge fuse
Transformer, Controller Power	WW300	QL-9R	120VAC step-down

Table B-2: Control System Parts

Part	Part Numbers		Additional Information
Controller, Complete	WW322	—	specify sampler model
Controller Backup Battery	WW390	—	CR2032
Controller Face Plate	WW354	QL-1	
Controller Face Plate Gasket	WW355		
Controller Logic Board	WW401	QL-2	specify controller model
Controller Power Board	WW320	QL-3	
Field Inputs Connector	WW002	QL-13	female
Protective Cover	WW005		6-pin CPC panel connector, female
Mating Cable Connector	WW001	QL-14	male
Field Outputs Connector	WW024		female
Protective Cover	WW005		4-pin CPC panel connector, female
Mating Cable Connector	WW025		male
Float Switch, Bottle-Full	WW130		dry-contact, normally-closed
Load Cell Assembly	WW376	QL-56	load cell and control module
Pinch Valve Assembly	WW373	—	
Pinch Valve	WW193	QL-57	
Pinch Valve Cover	WW370	QL-58	

Table B-3: Intake and Discharge Line Parts

Part	Part Numbers		Additional Information
Discharge Funnel	WW??		
Intake Fitting, Compression	WW112	QL-16	
Intake Strainer, PVC & Stainless	WW189	QL-22	
Intake Strainer, Stainless Steel	WW181	QL-23	
Intake/Discharge Line Tubing, 3/8-inch I.D., flexible, clear	WW043		sold by the foot—specify length

Table B-4: Vacuum/Pressurization System Parts

Part	Part Numbers		Additional Information
Pressure Regulator, 20 psi	WW092		
Solenoid Valve, 4-Way	WW030	QL-8	
Vacuum Pump, Quick Lift	WW102	QL-6R	1/3 HP, 120 VAC piston pump
Vacuum Pump Mounting Pads	WW131	QL-7R	4 required
Vacuum Pump Service Kit	WW298	—	
Velocity-Limiter, Bleed Valve	WW033	QL-15	a.k.a. Pisco Valve
Velocity-Limiter, Check Valve	WW019	QL-75	

Table B-5: Top-Feed Sample Chamber Parts

Part	Part Numbers		Additional Information
Chamber Body	WW408		preassembled if ordered together
Chamber Lid	WW407	—	
Chamber Gasket	WW425		
Discharge Hose	WW050	QL-60	specify 6 inch length
Sample and Vacuum Elbows	WW435		2 required
Nuts	WW434	—	

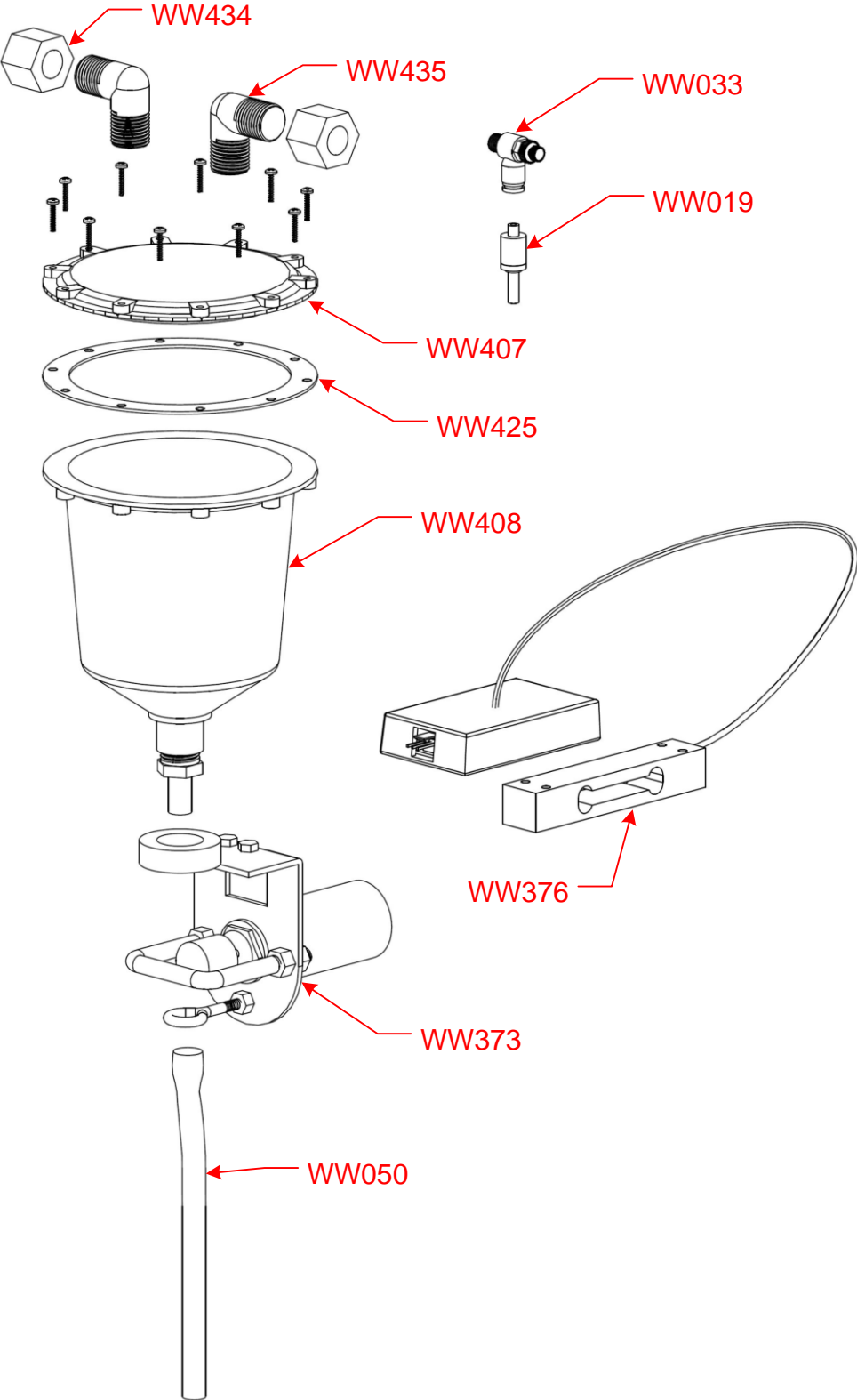

Figure B-2: QLS Top-Feed Sample Chamber

