

Century 3000 QLS

Refrigerated Wastewater Samplers
Composite and Sequential Models



Operations and Maintenance Manual Rev. B February 2019

Part Number: 692303312



4700 Superior Street • Lincoln, NE 68504
(402)464-0231 • (800) 228-4373
www.teledyneisco.com

Teledyne Isco Two Year Limited Factory Service Warranty*

This warranty exclusively covers Teledyne Isco instruments, providing a two-year limited warranty covering parts and labor.

Any instrument that fails during the warranty period due to faulty parts or workmanship will be repaired at the factory at no charge to the customer. Teledyne Isco's exclusive liability is limited to repair or replacement of defective instruments. Teledyne Isco is not liable for consequential damages.

Teledyne Isco will pay surface transportation charges both ways within the 48 contiguous United States if the instrument proves to be defective within 30 days of shipment. Throughout the remainder of the warranty period, the customer will pay to return the instrument to Teledyne Isco, and Teledyne Isco will pay surface transportation to return the repaired instrument to the customer. Teledyne Isco will not pay air freight or customer's packing and crating charges. This warranty does not cover loss, damage, or defects resulting from transportation between the customer's facility and the repair facility.

The warranty for any instrument is the one in effect on date of shipment. The warranty period begins on the shipping date, unless Teledyne Isco agrees in writing to a different date.

Excluded from this warranty are normal wear; expendable items such as desiccant, pH sensors, charts, ribbon, lamps, tubing, and glassware; fittings and wetted parts of valves; check valves, pistons, piston seals, wash seals, cylinders, pulse damper, diaphragms, inlet lines and filter elements, and damage due to corrosion, misuse, accident, or lack of proper maintenance. This warranty does not cover products not sold under the Teledyne Isco trademark or for which any other warranty is specifically stated.

No item may be returned for warranty service without a return material authorization number issued by Teledyne Isco.

This warranty is expressly in lieu of all other warranties and obligations and Teledyne Isco specifically disclaims any warranty of merchantability or fitness for a particular purpose.

The warrantor is Teledyne Isco, 4700 Superior, Lincoln, NE 68504, U.S.A.

*** This warranty applies to the USA and countries where Teledyne Isco does not have an authorized dealer. Customers in countries outside the USA, where Teledyne Isco has an authorized dealer, should contact their Teledyne Isco dealer for warranty service.**

Before returning any instrument for repair, please call, fax, or e-mail the Teledyne Isco Service Department for instructions. Many problems can often be diagnosed and corrected over the phone, or by e-mail, without returning the instrument to the factory.

Instruments needing factory repair should be packed carefully and shipped to the attention of the service department. Small, non-fragile items can be sent by insured parcel post. **PLEASE BE SURE TO ENCLOSE A NOTE EXPLAINING THE PROBLEM.**

Shipping Address: Teledyne Isco - Attention Repair Service
4700 Superior Street
Lincoln, NE 68504 USA

Mailing Address: Teledyne Isco
PO Box 82531
Lincoln, NE 68501 USA

Phone: Repair service: (800) 775-2965 (lab instruments)
(866) 298-6174 (samplers & flow meters)
Sales & General Information: (800) 228-4373 (USA & Canada)

Fax: (402) 465-3001

Email: IscoService@teledyne.com



February 2019 P/N 69-2303-312



Table of Contents

Warranty	2
Table of Contents.....	3
List of Illustrations.....	7
List of Tables.....	7
Specifications	8
Configuration Quick Start.....	9
Chapter 1: Introduction.....	12
1.1: Features.....	12
1.2: Physical Description.....	14
1.2.1: Temperature Control System.....	14
1.2.2: Sample Collection Systems.....	14
1.2.3: Sample Storage Systems.....	15
1.2.3.1: 10 or 20 Liter Bottle Insulation without turntable.....	15
1.2.3.2: Install Bottle Configuration: 24–500ml bottles.....	15
1.3.4: Sampling Control System.....	16
1.3.4.1: User Interface Panel.....	16
1.3.4.2: Inputs and Outputs.....	16
1.3.4.3: Sampling Programs	16
Chapter 2: Installation.....	18
2.1: Positioning the Sampler	20
2.1.1: Connecting Power	23
2.1.2: Hydrogen Sulfide Exposure.....	23
2.2: Sampling Line Connection.....	24
2.3: Velocity Control Valve Adjustment.....	25
2.4: Field I/O Connections.....	25
2.4.1: Flow Inputs	26
2.4.2: Relay Outputs.....	27
2.4.3: Float Input.....	27
Chapter 3: User Interface Panel.....	28
3.1: Control Buttons and Functions.....	29
3.2: Menu System	30
3.3: Administration Menu.....	32
3.3.1: Set Language.....	32
3.3.2: Administration Password.....	33
3.3.3: Clock Settings.....	34
3.3.4: LCD Brightness	35
3.3.5: Archival Data Administration.....	36
3.3.6: Set ID Number	36
3.3.7: Set Units (Volumetric).....	37
Chapter 4: Sampling Program Configuration.....	38
4.1: Program Selection.....	38
4.2: Program Configuration Groups.....	39
4.3: Sampling Cycle Settings.....	40
4.3.1: Pre-Sampling Purge Duration.....	40
4.3.2: Sample Size.....	41

4.3.3: Post-Sampling Purge Duration	41
4.3.4: Line Conditioning Rinses	42
4.3.5: RECYCLE (Sample Retry).....	43
4.3.6: Consecutive Sampling.....	43
4.4: Sampling Intervals	44
4.4.1: Timed Interval Sampling.....	45
4.4.1.1: Fixed Length Intervals.....	45
4.4.1.2: Variable Length Time Intervals.....	46
4.4.2: Flow Interval Sampling	47
4.4.2.1: Analog Flow Input.....	48
4.4.2.1.1: Fixed Volume Flow Interval	49
4.4.2.1.2: Variable Volume Flow Interval.....	49
4.4.2.2: Pulsing Flow Input	50
4.4.2.2.1: Fixed Pulses Flow Intervals	50
4.4.2.2.2: Variable Pulses Flow Intervals.....	51
4.4.3: Time+Flow Interval Sampling.....	51
4.4.4: Per-Bottle Timed Interval Sampling.....	52
4.4.5: Per-Bottle Flow Interval Sampling.....	53
4.5: Bottle Options.....	53
4.5.1: Composite Sample Containers.....	54
4.5.2: Discrete/Sequential Sample Containers.....	55
4.5.2.1: Bottle Indexing Options.....	56
4.5.2.2: After Time Indexing.....	57
4.5.2.3: Real Time Indexing	57
4.5.3: Installing the Sequential Drive Table (Platinum only)	57
4.5.4: Remove Sequential Sample Bottles (Platinum only).....	58
4.6: Program Run Options.....	59
4.6.1: Automatic Rerun.....	59
4.6.2: Delayed Start.....	60
4.6.3: Fault/Alarm Option.....	60
4.6.4: Float Option	61
4.6.5: Timed Stop.....	61
4.6.6: Bottle Limit Override	62
4.7: Program Event.....	63
4.7.1: Reviewing Scheduled Events.....	63
4.7.2: Adding and Editing Events	64
4.7.3: Deleting Events	66
4.7.4: Disabling Events	67
Chapter 5: Sampler Operation	68
5.1: Ready State	70
5.2: Sampler Conditions	71
5.3: Starting the Selected Program.....	71
5.3.1: Timed-Delay Starting	71
5.3.2: Float-Delayed Starting	72
5.3.3: Timed Starting	72
5.3.3.1: Timed State	73
5.3.4: Scheduled Starting.....	73
5.4: Running State.....	74
5.4.1: Sampling Intervals.....	75

5.4.2: Sample Container Screens	75
5.4.3: Sampling Cycle	76
5.4.3.1: Incomplete Sample Recycling	78
5.4.3.2: Manual Sampling	78
5.5: Paused and Halted States	79
5.5.1: Grab Sampling	80
5.5.2: Sample Calibration	81
5.5.3: Float Suspended Sampling	81
5.6: Stopping the Program	82
5.6.1: Continuous Operation	82
5.7: Reviewing Archived Data	83
Chapter 6: Maintenance	86
6.1: Periodic Maintenance Checklist	86
6.1.1: Sample Chamber Removal	86
6.1.2: Cleaning the Sample Chamber	86
6.1.3: Sample Chamber Installation	86
6.1.4: Cleaning or Replacing Wetted Parts	88
6.1.5: Sample Chamber Guidelines	88
6.1.6: Verifying the Temperature	88
6.2: Refrigeration System Maintenance	89
6.2.1: Adjusting the Thermostat	90
6.3: Compression/Vacuum Pump	92
6.4: Control System Fuse	93
6.5: Troubleshooting Tips	94
Appendix A: Controller Capabilities	96
A.1: Overview	96
A.1.1: Supervisory Routine (Ready State)	96
A.1.2: Menu System Outline	97
A.2: Inputs and Outputs	100
A.2.1: Run-Status Output	100
A.2.2: Alarm Output	100
A.2.3: Turntable I/O	100
A.2.4: Temperature Input	101
A.2.5: Flow Input	101
A.2.5.1: Remote Sample Initiation	101
A.2.6: Float Input	102
A.2.6.1: Factory Menu Float Setting	102
A.2.7: Load Cell Controller	102
A.2.8: Sampling Outputs	102
A.3: Sampling Program	104
A.3.1: QLS Sampling Cycle	105
A.3.1.1: Automatic Calibration	105
A.3.1.2: Calibrate Menu	106
A.3.1.3: Sample Recycling	106
A.3.2: Sample Intervals	107
A.3.2.1: Variable Intervals	107
A.3.3: Bottle Options	108
A.3.3.1: Composite Sampling	108
A.3.3.2: Sequential Sampling	108

A.3.3.2.1: After-Bottle Indexing.....	109
A.3.3.2.2: After-Sample Indexing.....	109
A.3.3.2.3: After-Time Indexing.....	109
A.3.3.2.4: Real Time Indexing.....	110
A.3.3.3: Per Bottle Sampling.....	110
A.3.3.4: Duplicate Sampling.....	111
A.3.4: Delayed Starting.....	111
A.3.5: Timed Stopping.....	112
A.3.6: Schedule Events.....	112
A.3.7: Data Archiving.....	113
Appendix B: Replacement Parts.....	114
Electrical Diagram.....	121

List of Illustrations

Figure 1-1:	Sampler Front	13
Figure 1-2:	Sampler Left.....	13
Figure 1-3:	Sampler Right Side	13
Figure 1-4:	Sequential Turntable assembly	14
Figure 2-1:	Liquid Flow Input Connection and Strainers	24
Figure 2-2:	Velocity Control Valve	25
Figure 2-3:	Flow Input Connections Diagram.....	25
Figure 2-4:	Relay Output and Float Input Connections.....	26
Figure 2-5:	I/O Output Connector	27
Figure 3-1:	User Interface Panel.....	28
Figure 5-1:	User Interface Panel and Icons	68
Figure 6-6:	Sampler Pump & Electrical Compartment	92
Figure 6-7:	Quick Lift Compressor/Vacuum Pump and Service Kit.....	92
Figure 6-8:	Control system fuse holder in open and tripped positions	93
Figure A-1:	QLS Flow Sequence	103
Figure A-2:	QLS Sampling Cycle.....	104
Figure A-3:	Basic Sample Timing Diagram.....	107
Figure B-4:	Sequential Bottle Kits.....	117
Figure B-5:	Composite Bottle Kits.....	117
Figure B-6:	Sample Chamber and Pinch Valve Components	118
Figure B-7:	Sequential Table Parts.....	119
Figure B-8:	Electrical Components	120

List of Tables

Table 1-0:	Specifications.....	8
Table 1-1:	Century 3000 QLS Features	14
Table 2-1:	I/O Output Connector	27
Table 3-1:	Control Buttons	29
Table 5-1:	User Interface Panel and Icons.....	69
Table A-1:	Available Program Event Types.....	112
Table B-1:	Labels and Controller	114
Table B-2:	Exterior Parts.....	115
Table B-3:	Inside the Sampler.....	116
Table B-4:	Sequential Bottle Kits.....	117
Table B-5:	Composite Bottle Kits.....	118
Table B-6:	Sample Chamber and Pinch Valve Components	118
Table B-7:	Sequential Table Parts.....	119
Table B-8:	Electrical Components	120

Specifications	
Size (HxWxD):	43 x 20 x 24.25 in. 110 x 51 x 62 cm
Weight (empty):	120 lbs. (55 kg)
Bottle Configurations:	3 configurations available: 24, 500ml- PP 1, 20-liter PE 1, 10-liter PE or glass
Refrigerator Body:	Black enamel painted steel
Power Requirements:	115 VAC \pm 10%, 60 Hz:
Installation Category:	II
Pollution Degree:	3
Maximum Altitude	6,562 feet (2,000 m)
Operational Temperature	32 to 120 °F (0 to 50° C)
Tubing	
Intake Suction Tubing Length	1 to 45 m 3 to 150 feet
Material:	Vinyl or FEP-lined polyethylene
Inside Diameter:	3/8 in. 9mm
Maximum Suction Lift	28ft (Optional) (8.5m) 23ft (Standard) (7.0m)
Typical Repeatability:	\pm 5 ml or \pm 5%
Typical Line Velocity at Head Height:	3/8 IN. suction line 3ft: 9.84ft/s 10ft: 7.38ft/s 20ft: 4.48ft/s
Liquid Presence Detector	Non-wetted, non-conductive weight measurement feedback to the controller.
Controller	
Enclosure Rating:	NEMA 4X, IP66
Program Memory:	Non-volatile ROM (Flash)
Flow Meter Signal Inputs	Pulses (dry contacts) 4-20 mA 0-5 VDC 0-10-VDC
Digital Alarm:	1 output, with 5 alarm configurations.
Number of Composite Samples:	Programmable from 1 to 999 samples.
Internal Clock Accuracy:	1 minute per month at 25°C
Software	
Sample Frequency:	1 to 9,999 minutes, in 1-minute increments. 1 to 9,999 flow pulses.

Century 3000 QLS Refrigerated Sampler

Programmable Sample Volumes:	20 to 500 ml in 1 ml increments
Rinse Cycles:	Rinsing of suction line up to 4 rinses for each sample collection.
Sampling Modes:	Constant Time, Constant Volume Variable Time, Constant Volume Constant Flow, Constant Volume Variable Flow, Constant Volume Time and Flow Based Sampling (refer to manual for more info) Incremental Time per Bottle Incremental Flow per Bottle
Sample Recycle (Retry)	If no sample is detected or less than 60% of programmed value collected, recycle activated up to 4 attempts.
Controller Diagnostics:	Tests for RAM, load cell error, indexing error. Live diagnostics while sampling.

QLS - Quick Start

At initial power up, the controller displays the Program Ready Screen:

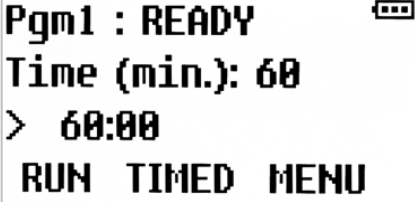

```

Pgm1 : READY
Time (min.): 60
> 60:00
RUN TIMED MENU
  
```

- 1) To run the displayed program, select F1 for RUN.
 - Program timer begins and the program runs as specified.
 - Select F1 to STOP the program at any point of the program running mode.
 - Select F1 again to RESET the program and go back to the Pgm Ready Screen.
- 2) To configure the program settings, select F3 for MENU. Use the arrows to the right of the display to scroll through the programs (1-6). Press F3, or SEL to select the program to configure.
 - Optionally scroll through the Program Configuration (PGM CONFIG) menu using the arrow keys to select which program setting to configure. The following list displays all of the variable sub-settings within each program setting.

PGM CONFIG:

- Cycle: Set the sampling parameters here.
 - PREPURGE: Enter the number of seconds (0-99) for the system to purge the intake lines prior to sampling. Then press F3 to accept.
 - SAMPLE SIZE: Enter the desired sample volume in milliliters/grams (20-500mL). Then press F3 to accept.
 - POSTPURGE: Enter the number of seconds (10-99) for the system to purge the intake after the sample is taken. Press F3 to accept.
 - NUM. RINSES: Enter the number of times (0-4) the intake line should be rinsed, prior to each sample. Press F3 to accept. Warning: when entering rinse/vacuum time, ensure that the sample does not reach the sampler during the rinse.
 - PRESSURE TIME: This menu item displays only if the Number of Rinses is not zero. Type in the number of seconds (0-99) each rinse should pressurize the sampler chamber. Press F3 to accept.
 - VACUUM TIME: Enter the number of seconds (0-99) each rinse should vacuum. Press F3 to accept. **(Do not allow the sample to enter the sample chamber)**
 - RECYCLE: Use up and down arrows to enable or disable the sample retry feature or press F3 to accept the setting. When the recycle feature is enabled, the sampler makes a second attempt to take the sample, if it failed to collect a sample on the first try.
 - CONSECUTIVE SMP: To draw just one sample per interval, type 1 and press F3 to accept.
- Smpl. Interval
 - SMPL. INTERVAL: Press F3 to select the Sampling Interval setting. Use the up and down arrows to scroll through the options and select F3 to accept. Generally, the sampling interval is a set time, in between samples.
 - TIME OPTION: Use the up or down arrow keys to scroll to the desired option (e.g. Time Fixed). Press F3 to accept.
 - SMPL MIN: Use the keypad to enter the desired Sampling Time Interval or leave as is, then press F3 to accept.

- Bottle Opts.
 - SAMPLE TYPE: Use arrows to scroll and press F3 to select Composite or Discrete/sequential sampling. If Discrete sample type was selected, the next menu is BOTTLE CONFIG. Use the arrows to scroll to the desired bottle configuration that is installed in the sampler, then press F3 to select.
 - NUM. BOTTLES: Enter the number of bottles that you want to use, otherwise press F3 to accept the default setting to use all the bottles.
 - SMPLS/BOTTLE: Enter the number of samples that you want to collect in every bottle. The maximum number of samples per bottle is defaulted; press F3 to accept this setting.
 - INDEX TYPE: Use the arrows to scroll to the desired indexing type. The “After Bottle” setting is defaulted, which tells the program to rotate to the next bottle, once all of the specified samples are discharged into the current bottle. Press F3 to accept this setting.
- 3) After entering these settings, the screen will return to the PGM CONFIG menu, signifying that the program setup is complete. If you do not wish to enable any PROGRAM RUN OPTIONS (Section 4.6), press F1 twice to return to the Program READY screen.
- 4) Press F1 to begin the program. The first sample will be taken once the turntable reaches the home position (bottle #1).

IMPORTANT: Do make sure that the discharge tube is directly above bottle 1 when the table finds the home position and stops. Failure to do this may result in spilling.

Calibration:

- 1) To properly calibrate the volume prior to running a program, you must go to MAIN MENU and scroll to find the CALIBRATE menu item. Press F3 SEL to select the menu item.
- 2) Calibrate #1 is displayed, press START (F3) to take a calibration sample. Discard the sample or proceed to Calibrate #2. There is a maximum of 3 Calibration iterations, then a Calibration Complete screen displays when the program is calibrated and ready to run.
- 3) Discard the calibration samples and press HOME (F1) to go to Program Ready Screen.

Grab Sampling:

- 1) A Grab sample (volume test sample) can be taken at any time while program is running.
- 2) When the program is running, push PAUSE (F3). Then push GRAB (F2) to enter grab mode.
- 3) Grab Smpl Size: enter the desired grab sample volume you would like to test. The sample volume that the current program is running will be populated in the volume field.
- 4) If the grab sample size is the same as the current program sample size, the screen will display Grab #1 and is ready to take a grab sample. If the desired Grab sample size is different from the current program sample volume, you may need to calibrate the grab sample volume. A Grab Calibrate screen will require you to complete calibration before taking a grab sample.

Velocity Control valve adjustment instruction:

- 1) Close the valve all the way (rotate clockwise) if lift height is greater than 3 meters.
- 2) Open the valve all the way (rotate counterclockwise) if lift height is 1 meter or less.
- 3) If the lift height is between 1 and 3 meters, close the valve all the way, then open two complete rotations. The sampler is always shipped at this setting.

Chapter 1: Introduction

Refrigerated QLS Samplers collect specified volumes of wastewater at programmed time or flow intervals and deposit them into refrigerated composite or sequential sample containers. The patented **Quick Lift Sampler (QLS)** systems precisely weigh each sample and self-calibrate to maintain the specified sample size. Their piston vacuum pumps provide long-term consistent sampling with vertical lifts of up to 28 feet, with no frequent maintenance required.

The QLS refrigerated sampler uses an indoor refrigerator with the controls mounted on top. If you have any questions or suggestions, feel free to call Teledyne ISCO at 1-800-228-4373.

1.1: Features

The Century 3000 QLS sampler features are identified in Figures 1-1 through 1-3 and described in table 1-1.

Table 1-1 Century 3000 CVE-16 Sampler Features	
1.	Control Enclosure
2.	Control Panel
3.	Discharge Tube
4.	Sample Chamber
5.	Sequential Table
6.	Refrigerator Door
7.	Door Latch
8.	Load Cell
9.	External Device Connector (4pin)
10.	Refrigerator
11.	Sample Line Intake
12.	I/O Connections (7 pin)
13.	Pinch Valve Assembly
14.	Lifting the sampler

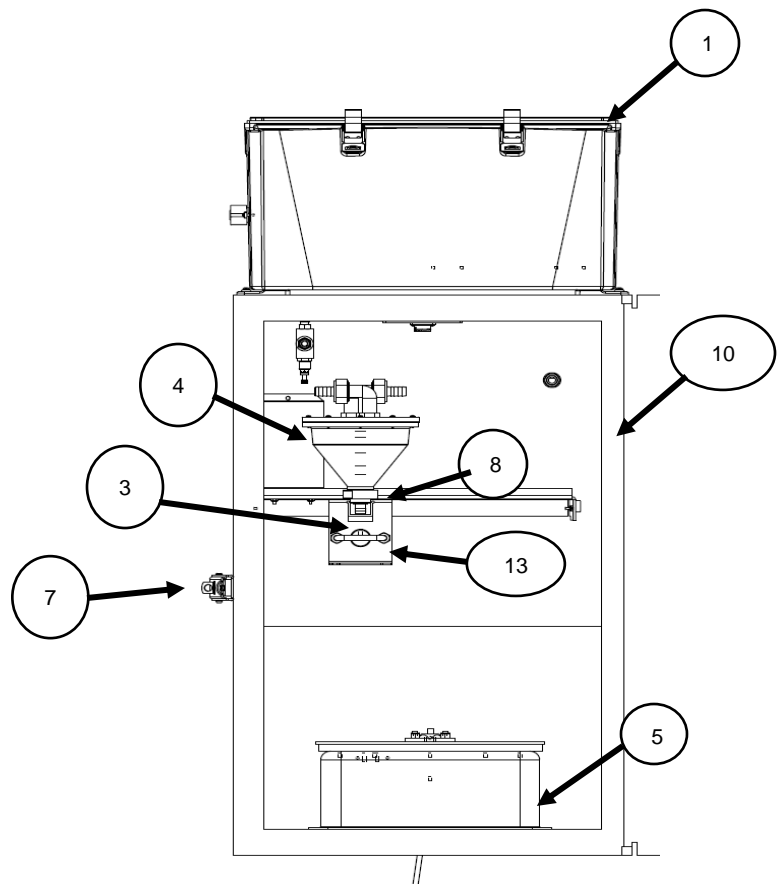

Figure 1-1 Sampler Front

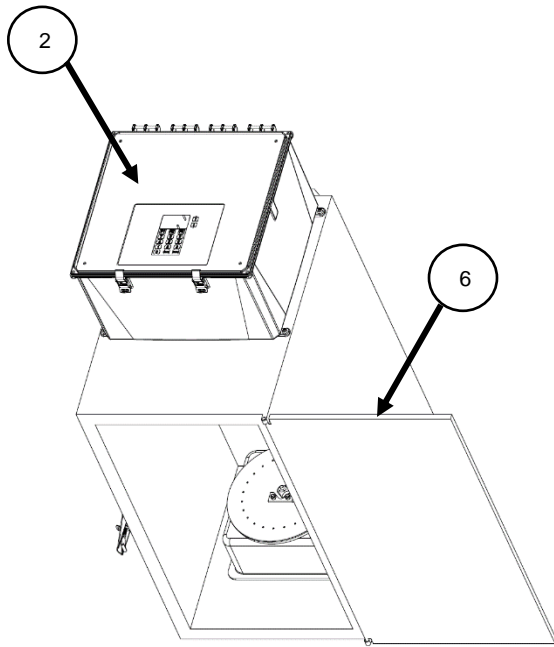

Figure 1-2 Sampler Top

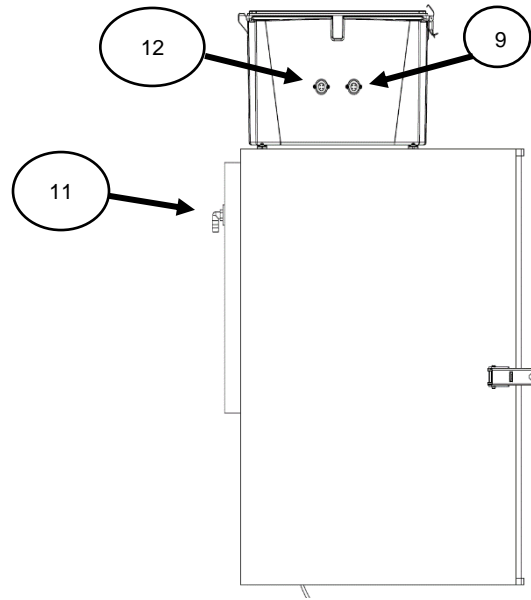

Figure 1-3 Sampler Right Side

Table 1-1 Century 3000 QLS Features

Item	Name	Description
1	Control Enclosure	Protects the control and sampler components.
2	Control Panel	Supports user control and programming of sampler operation.
3	Discharge Tube	Carries liquid to the sample bottle.
4	Sample Chamber	Sample is measured and collected in the chamber then discharged into sample container
5	Sequential Table	Rotates the bottles.
6	Refrigerator Door	Protects the collected samples inside the refrigerated compartment.
7	Latch	Secures the door. The latch mechanism may be locked with a user supplied padlock.
8	Liquid Detector	The non-wetted load cell utilizes weight measurement feedback to the controller with continuous self-calibration.
9	External Device Connection	Supports connections to external devices such as a flow meter for sample pacing or for a 4-20mA input
10	Refrigerator	Refrigerates the samples
11	Sample Line Intake	The sample intake line connects here.
12	Aux. Outputs	Alarm, Fl. Start, Fl. Start/Stop, Run Status
13	Pinch Valve Assembly	Pinch Valve pushes the discharge hose closed.

1.2: Physical Description

The components of each refrigerated QLS Sampler are mounted in two parts, refrigerator and control.

1.2.1: Temperature Control System

The temperature is control by the thermostat mount inside the refrigerator. The temperature is adjusted by turning the temperature control knob clockwise for colder settings.

1.2.2: Sample Collection Systems

The sample collection system has the following major components:

- A clear plastic **sample chamber** with a discharge-tube **pinch valve**.
- A **load cell** (and its control unit) that weighs the sample chamber as each sample is being drawn.
- A **vacuum/pressure pump** connected to that chamber by a four-way **solenoid valve**, which alternately evacuates and pressurizes the sample chamber in order to draw wastewater in, as well as to purge the system.
- A pump discharge **pressure regulator** and intake **velocity control valve**.
- A 3/8 inch **intake sampling tube** that extends to the sampled wastewater stream.

The sample chamber and load cell are mounted in the **sample compartment**, which also houses the sample storage system and is accessed through the unit's front door.

The pump, solenoid valve, pressure relief valve, step down transformer and fuse are located in the control box which is mounted on top of the refrigerator.

1.2.3: Sample Storage Systems

Refrigerated QLS Samplers can be configured with either composite or sequential sample storage systems, which are installed in their sample compartments.

Composite-storage systems deposit all samples into a single large container.

Sequential-storage system deposit samples into multiple bottles.

If the sampler is configured for composite sampling, place the discharge tube in the center of the sample bottle. Make sure the discharge tube does not come in contact with the sample bottle. If the sample tube touches the sample bottle the sampler cannot measure the sample properly. Refer to the instructions for your bottle size.

1.2.3.1: 10 or 20 Liter Bottle Installation without turntable

1. Remove cap (lid) and position the bottle under the discharge tube. Install a discharge tube if needed. **IMPORTANT:** Make sure the discharge tube does not contact the bottle in any way.
2. Go to BOTTLE OPT. in the Menu and select COMPOSITE and then select your bottle size.

<input checked="" type="checkbox"/> Note

The composite containers are not designated to be used in the sampler along with the sequential table installed. If switching from sequential to composite sampling, the sequential turntable needs to be removed. In Bottle Opt. under the program menu, select Composite sampling.

Sequential-storage systems have multiple sample bottles twenty-four 500ml bottles sitting on a turntable-mounted carousel, which are rotated under the sample chamber and filled as specified by the sampling program.

Each program can be set to discharge one sample into each bottle, then a second sample into each, and so on—stopping after each bottle has received the specified number of samples; or the specified number of samples into the first bottle, the same number into the second bottle, and so on—stopping after the last bottle has been serviced.

Figure 1-4: Sequential Turntable Assembly

Align the drive block with the square opening on the bottom of the tub.



1.2.3.2: Install Bottle Configuration: 24-500 ml bottles

The 24 bottle configurations use a rack to hold and align the containers. To install the bottles in the refrigerator using the rack:

- 1) Place the uncapped bottles into the rack. Install the bottle retaining ring in the center of bottles using the 3 bungee cords.
- 2) Locate the arrow in center of the rack and align it with the center block located on the turntable. (**Make sure the program is set for the proper bottle configuration before running the program**).
- 3) Activate the program to RUN and the table will turn to locate Bottle 1. After the table has stopped make sure the discharge tube is centered in the bottle. If the discharge tube is not centered, rotate/adjust the discharge tube to the center of the bottle.

Note: Make sure that in the program settings under BOTTLE OPT. The Sample Type is set to Discrete and the proper bottle configuration is selected.

1.3: Sampling Control System

Each sampler has a control mounted in a NEMA 4x enclosure. The control consists of a power board and a logic board.

- a 32-bit microcontroller that can run any of six **sampling programs**
- a **backup battery** that powers the microcontroller's **real-time clock** but not its field elements (thus precluding continued sampling) when external power is unavailable
- the onboard **user interface keypad**
- a variety of discrete and analog **inputs and outputs** (see next page)
- **SDI-12 communication interface** for the load cell controller

1.3.1: User Interface Panel

The controller's LCD readout and password-protected keypad are located under the control lid. They are used to:

- Adjust the clock and the LCD brightness/contrast, and administer the access passwords and archival data (see Chapter 3: User Interface Panel);
- Configure the sampling programs (see Chapter 4: Sampling Program Configuration)
- Monitor and control the unit's operation (see Chapter 5: Sampler Operation).

1.3.2: Inputs and Outputs

Each controller's logic board supports a variety of field input and output signals, some are wired directly to logic board connectors while others are routed through additional circuitry and connectors on the power board:

- All of the controller's required and optional inputs and outputs are described in detail in Appendix A.
- Those circuits, and the circular plastic connectors (CPCs) to which the corresponding field devices must or can be wired, are shown on the Electrical Diagram appended to the back of this manual.

Instructions for connecting your field devices to the controller's external CPCs are provided in Chapter 2.

1.3.3: Sampling Programs

Each control system provides six user-configurable sampling programs, one of which is selected and can be run at any given time. Each of those programs can be configured to:

- Draw configurable, fixed-size (20 to 500 milliliter) samples, or sets of consecutive samples, at specified time or flow intervals.
- Flow intervals can be based on either an analog or a discrete-pulse flow meter signal, or a PLC or other remote device could use the pulsing flow input to trigger individual samples.
- Rinse the sampling line up to four times prior to drawing each sample.
- Repeat any sampling cycle up to four times (five total) if needed to collect the specified volume of wastewater.
- Discharge each sample into a specified sequential-sampling bottle (if so equipped).
- Delay its execution a specified number of minutes after it is started, or until the optional float input is asserted.
- Automatically stop after a configurable amount of time or number of samples, or if the sample volumes discharged to any bottle exceed 90 percent of its capacity. AND/OR Suspend and Resume sampling as an optional external float switch opens and closes.
- Alternately, a PLC or other remote device could use the external float-switch input to remotely suspend and resume the collection of samples.
- Start sampling, pause or halt and later resume, take manual samples, and finally stop at scheduled times on specified days of the week, then automatically restart itself if desired.
- Energize a run-status relay to indicate a sample is being collected, or an alarm relay to indicate the program has stopped or encountered a fault condition.

Appendix A: Controller Capabilities discusses the configurable features of the sampling program, while Chapter 4: Sampling Program Configuration tells how to view and change the parameters that configure those features.

Chapter 2: Installation

The refrigerated samplers are meant to be used in fixed locations, with any optional external I/O devices connected, the far ends of their sampling lines fixed in the waste streams they are to sample, and their power cords plugged into alternating-current power receptacles.

When you are ready to install your sampler:

1. Move it to its intended final location, remove its protective packaging, lift it from its shipping pallet and set it in its intended position.
2. Adjust the feet so the sampler is approximately level.
3. Install the wastewater intake line(s) and strainer(s).
4. Connect any external I/O devices (flow and/or float inputs, run and/or alarm outputs).
5. Plug the provided power cord into a grounded AC power receptacle.
6. Verify or correct the control system clock settings (Chapter 3.2.3).
7. Configure the sampling program(s) to your needs (Chapter 4).
8. When lifting small samples, you may need to adjust the velocity valve (Chapter 2.3).

2.1: Positioning the Sampler

There are a few considerations when selecting a site for the sampler. The foremost concern should be personal safety.

The installation and use of this product may subject you to dangerous working conditions that can cause you serious or fatal injuries. Take any necessary precautions before entering the work site. Install and operate this product in accordance with all applicable safety and health regulations, and local ordinances.

The refrigerated samplers can be installed in nearly any indoor locations. Make sure the sample lift does not exceed 23 feet (optional 28ft.). Keep in mind the sample hose will be about 4 feet above the surface the sampler sits on.

You should provide clearance to each side of the cabinet (for cooling air flow and electrical and sample line clearance). As little as 2 inches of rear clearance is sufficient, although servicing the refrigeration unit would then require you to move the unit forward to provide 3 feet of space. Anything mounted over the sampler should be at least 5 feet above the floor.

If lift trucks and/or other moving equipment are frequently operated in the selected area, you might want to install protective barriers to keep them from running into the sampler.



If this product is used in a manner not specified in this manual, the protection provided by the equipment may be impaired.



This product has not been approved for use in hazardous locations as defined by the National Electrical Code.



The sampler is heavy. When lifting, use a two-person lift from the right and left sides. When possible, move the sampler using a two-wheeled hand cart from the side. To prevent damage to the refrigeration system, do not tip the sampler more than 45°.

Dangerous locations – If you must enter a manhole, confined space, or other dangerous location to install the suction line and strainer, observe standard safety precautions. Refer to Appendix B of the Installation and Operation guide for a discussion of safety considerations.

Support – The sampler should be installed on a surface capable of safely supporting the sampler, full liquid containers, and personnel.

AC Power – The mains line cord is the disconnect device should you need to remove power. Therefore, the electrical power outlet should be accessible.

Environmental – The sampler is designed for outdoor use. Refer to Table 1-2 for environmental specifications. When possible, avoid subjecting the sampler to chemical attacks and direct sunlight.

Avoid submersion – Although the control panel will resist damage (rated NEMA 4x) the refrigerator system and bottle compartment cannot prevent liquid from entering. In the event of submersion, liquid entering the refrigeration system could permanently damage the sampler; liquid entering the bottle compartment could contaminate the collected samples. Liquid entering the electrical compartment for the refrigeration system could result in a short circuit and possible shock hazard.

Liquid sample collection point – It is best to keep the distance between the sampler and the collection point as short as possible. The sampler inlet should be located above the liquid surface to be sampled with no liquid traps. Gravity will aid suction line rinses and allow the line to drain, thereby reducing the possibility of sample cross-contamination. Refer to Table 1-2 for maximum suction line lengths and suction head heights.

Security – The sample compartment and control panel have a padlock feature, but the location may need additional security to prevent tampering or vandalism.

Accessibility – The sampler must be installed in a location where personnel can easily exchange bottles and perform routine service.

The sampler requires about 2600 square centimeters (925 in²) of floor space. Additional space must be allowed in front of the sampler, at its left and right sides, and above. Do not block access to these areas. Obstructions will make routine servicing activities difficult or impossible. The back of the sampler may be placed against a wall as long as air from the side vents are unrestricted air can flow freely. Unrestricted air flow behind and around the sampler will allow the refrigeration system to work efficiently.

Level surface – The sampler should be placed on a level surface and the feet on the refrigerator body should be adjusted to prevent tipping or spills. If the sampler is not level, the sample liquid may miss the bottle mouth. To level the sampler, place a bubble level on the top of the refrigerated compartment.



Do not tip the sampler on its side or back. Tipping the sampler more than 45° might cause the oil to run into the compressor inlet, which can permanently damage the refrigeration system.

2.1.1: Connecting Power



Before connecting the sampler to an AC power source, be familiar with the Electrical Requirements.

The factory assembles the sampler for 115 VAC/60 Hz. The serial number label located inside the control cover identifies the AC power configuration of your sampler. You cannot convert the sampler in the field.

The mains power cord for 115 VAC samplers is equipped with a NEMA 5-15P plug for standard North American outlets. Plug the mains power cord into the outlet. The sampler control panel will briefly show this start up display:



2.1.2: Hydrogen Sulfide Exposure

Although the copper tubing in Refrigerated Samplers QLS refrigeration units is coated to resist hydrogen sulfide (H₂S) corrosion, the high concentrations of that gas present in some areas of a wastewater treatment facility can still create pin-hole leaks after as little as a year or two of exposure. Therefore, you should **select an installation location where the concentration of that gas is as low as possible**. Because H₂S is heavier than air, higher elevation locations are favored, as well as areas with adequate air circulation.

2.2: Sampling Line Connection

The wastewater inlet connection is a 1/2-inch FNPT fitting located in the back of the sampler on the upper right side. The sample line is 3/8" I.D x 5/8" O.D. clear PVC tubing. The intake tubing and strainer can be ordered from Teledyne ISCO.

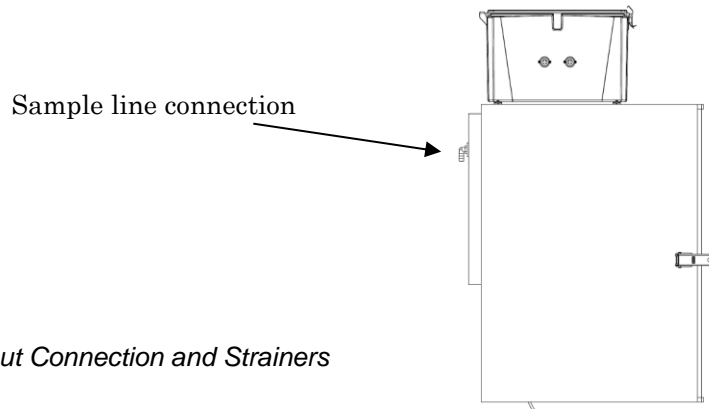
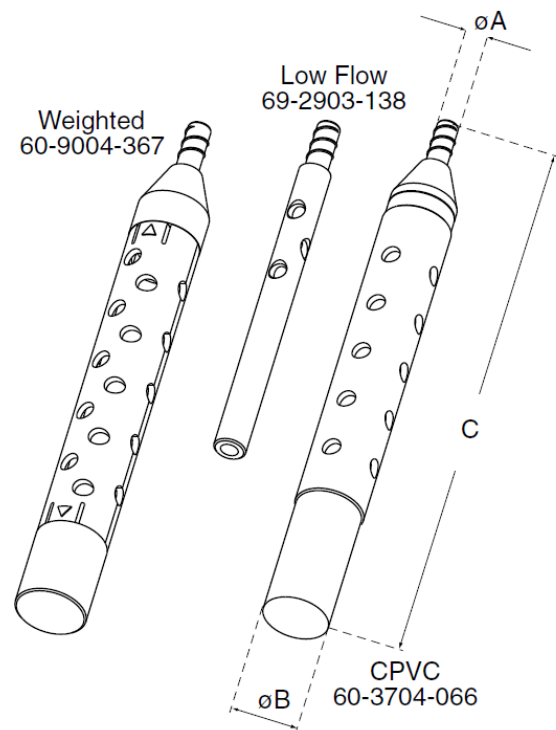

Figure 2-1: Liquid Flow Input Connection and Strainers

Strainer:

To attach the strainer to the suction line, carefully screw the strainer's threaded connector into the suction line. If attaching the strainer to an FEP-lined suction line, heat the suction line end before threading the strainer into the line. **Warming FEP-lined tubing will make it more pliable to avoid damage.**

- ⊘ *The QLS vacuum system cannot be used to sample pressurized wastewater streams, or open streams whose surfaces are higher than the sampler. Attempting to do so may fill the sampler with water and ruin it.*



Alternative to Strainers

When sampling from high velocity streams with heavy suspended solids, some field investigations suggest that more representative samples are obtained without the strainer. Consider attaching a short piece of thin walled aluminum tubing to the end of the suction line; anchor the tubing so that the inlet opens upstream. The aluminum tubing's thin wall will not disturb the flow stream, and most sample analyses disregard aluminum ions. Under most conditions, a pre-sample line rinse removes any debris over the tubing entrance.

Maximum Unanchored Length

During a pre or post-sample purge or line rinse, the suction line is filled with air which might cause the suction line and strainer to float. If the length of the suction line and strainer exceeds the listed value, securely anchor the strainer.

Even if the maximum length is not exceeded, it is a good idea to anchor the suction line and strainer when sampling from high velocity or turbulent flow streams.

Routing the Suction Line and Strainer

Route the suction line so that it has a continuous slope from the liquid source to the sampler. This helps to drain the line during pre and post-sample line purges and rinses. If a suction line exposed to freezing climates does not fully drain, there is a risk of liquid in the suction line becoming frozen. Frozen liquid will cause the sample collection to fail. A warm sampling source can usually prevent this, provided there are no traps or low spots in the suction line. Some extreme situations may require more protective measures, such as insulating the suction line or applying heat tape.

For representative samples, place the strainer in the main current of the flow stream, not in an eddy or at the edge of flow. Placing a strainer at the bottom may produce samples with excess heavy solids and no floating materials, while placing it at the top may produce the opposite conditions.

2.3: Velocity Control Valve Adjustment

The velocity control valve adjustment is to control the inlet velocity of the sample. The valve is located inside the refrigerator on the upper left side on the bottom of the PVC tee. The sample velocity can be adjusted by rotating the stainless-steel knob. Opening the valve decreases vacuum and the sample flow rate. In order to raise small samples short distances, you might need to further open the velocity-limiting valve:

- If the lift height is between 1 and 3 meters, close the valve all the way (rotate clockwise), then open two complete rotations (rotate counterclockwise). This is the default setting and the sampler is always shipped at this setting.
- Open the valve all the way if the lift height is 1 meter or less.
- Close the valve all the way if the lift height is greater than 3 meters.
- For very small sample volumes, the valve may need to be adjusted. If calibration is not achieved and the collected sample is too large, open the valve 3 to 6 turns to slow down the sample inlet velocity.

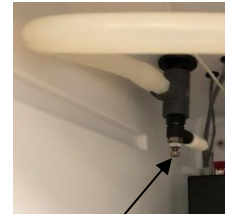

Figure 2-2: Velocity Control Valve

⊘ *Do not adjust the velocity-limiting valve while the sampling program is running!*

2.4: Field I/O Connections

Circular plastic connectors (CPCs) are mounted on the left side of control box. sides of Dual)
The field I/O devices:

- a four-pin flow inputs connector (analog and/or pulsing-discrete signals)
- seven-pin field I/O connector (alarm and run output and float input signals)

Custom cables must be fabricated (from the provided matching screw-terminal cable connectors) for any you chose to use.

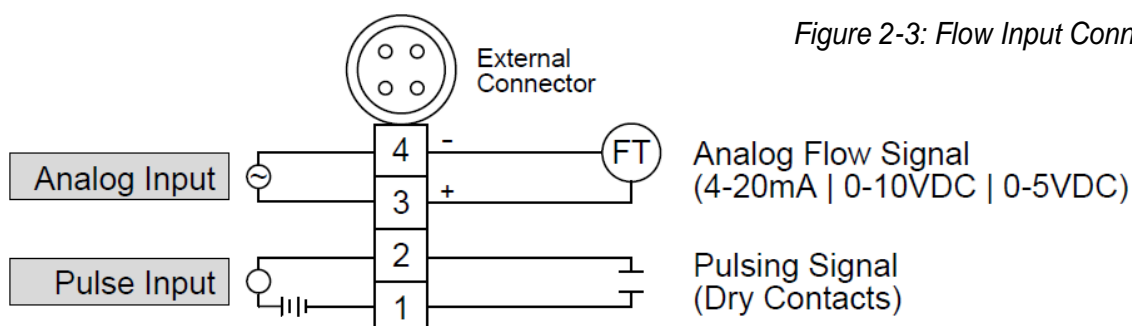

Figure 2-3: Flow Input Connections Diagram

2.4.1: Flow Inputs

The four-pin flow input connector provides field wiring terminals for pulse and analog flow input signals, either of which can be connected and used to trigger sample collection at configured stream flow intervals (Chapter A 2.6):

- If that feature is configured for a pulsing input, connect a dry-contact signal source to input connector pins 1 and 2. The interval pulse count will be incremented each time that controller-powered circuit is externally closed.
- ✎ *To adapt this input to an externally-powered discrete signal, connect it to the normally-open contacts of an interposing relay and use that signal to energize the relay coil.*
- If that feature is configured for a 4-to-20 mA, 0-to-5 V or 0-to-10 V analog flow signal, connect the transmitter's positive (+) and negative (-) terminals to input connector pins 3 and 4, respectively.

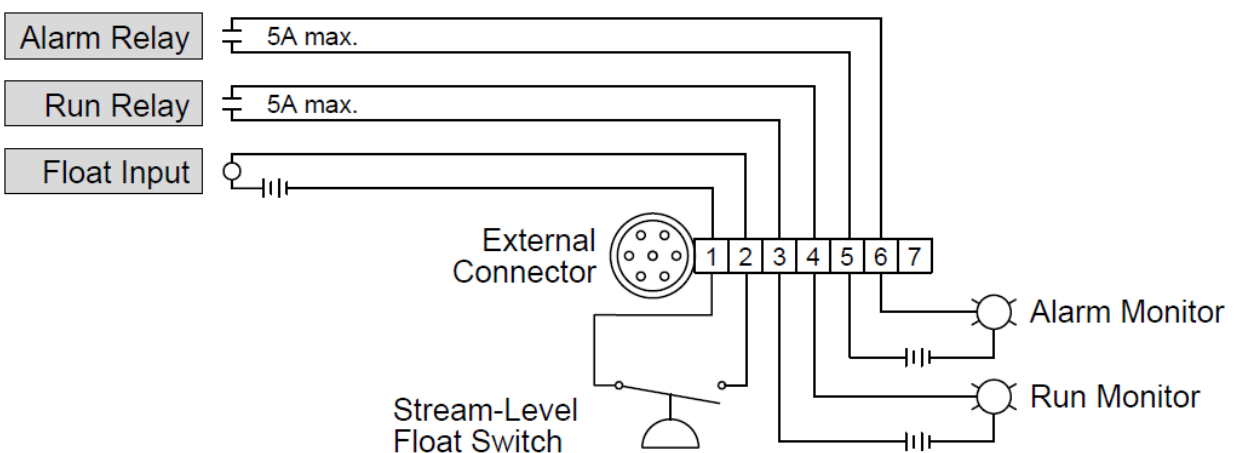
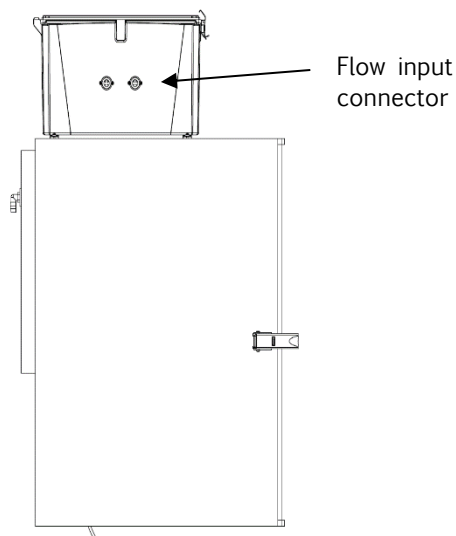

Figure 2-4: Relay Output and Float Input Connections

2.4.2: Relay Outputs

As shown above, four of the optional field I/O connector’s seven pins connect to 5 Amp relay contacts on the controller’s power board:

- the run-status relay connects pins 3 and 4 when the unit is sampling.
- the alarm relay (if enabled, Chapter 4.6.3) connects pins 5 and 6 when sampling is stopped or certain non-fatal fault conditions are detected (Chapter A 2.2).

They can thus be used to turn appropriate *externally-powered* indicator lamps or annunciators on and off, or to signal those conditions to a SCADA or other host control system.

Table 2-1: I/O Connector (7 pin)			
Pin	Wire Color	Signal Name	Parameters/ Comments
1	Orange	1.Float Start or 2.Float Start/Stop	Dry contact 1. Closed contact to initialize program start. OR 2. Closed contact to start the program and open contact stops the program.
2	Orange	Float Start or Start/Stop	
3	Blue	Run Status	Relay contact 250V 5 amp rated, closed contact during sample cycle
4	Blue	Run Status	
5	Red	Alarm	Relay contact 250V 5 amp rated, closed contact during a fault condition or when program is completed
6	Red	Alarm	

2.4.3: Float Input

Pins 1 and 2 (orange wires) of the seven-pin field I/O connector, which are internally wired to the controller’s self-powered float input, can be used to externally connect a dry-contact, normally- open, minimum-stream-level float switch.

Depending on which of the Float Input options has been factory-configured (Chapter A 2.6), enabling this input Chapter 4.6.3) will configure the sampling program to delay sample collection until that circuit closes and subsequently either:

- continue sampling even if the float circuit reopens, or
- toggle the collection of samples on and off as the rising and falling stream level closes and opens that circuit.

Due to the variety of suitable stream-level sensors that are available, contact Teledyne ISCO for more details.

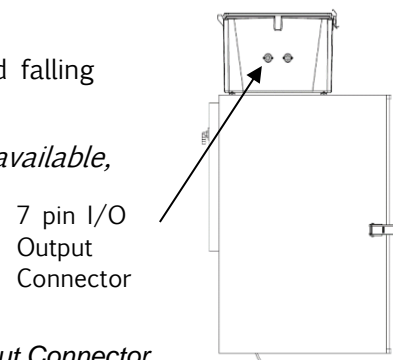

Figure 2-5: I/O Output Connector

Chapter 3: User Interface Panel

Each sampling system's operation can be configured, monitored and controlled using its user interface panel, which consists of a heated LCD readout and password-protected keypad located behind the upper-front door.

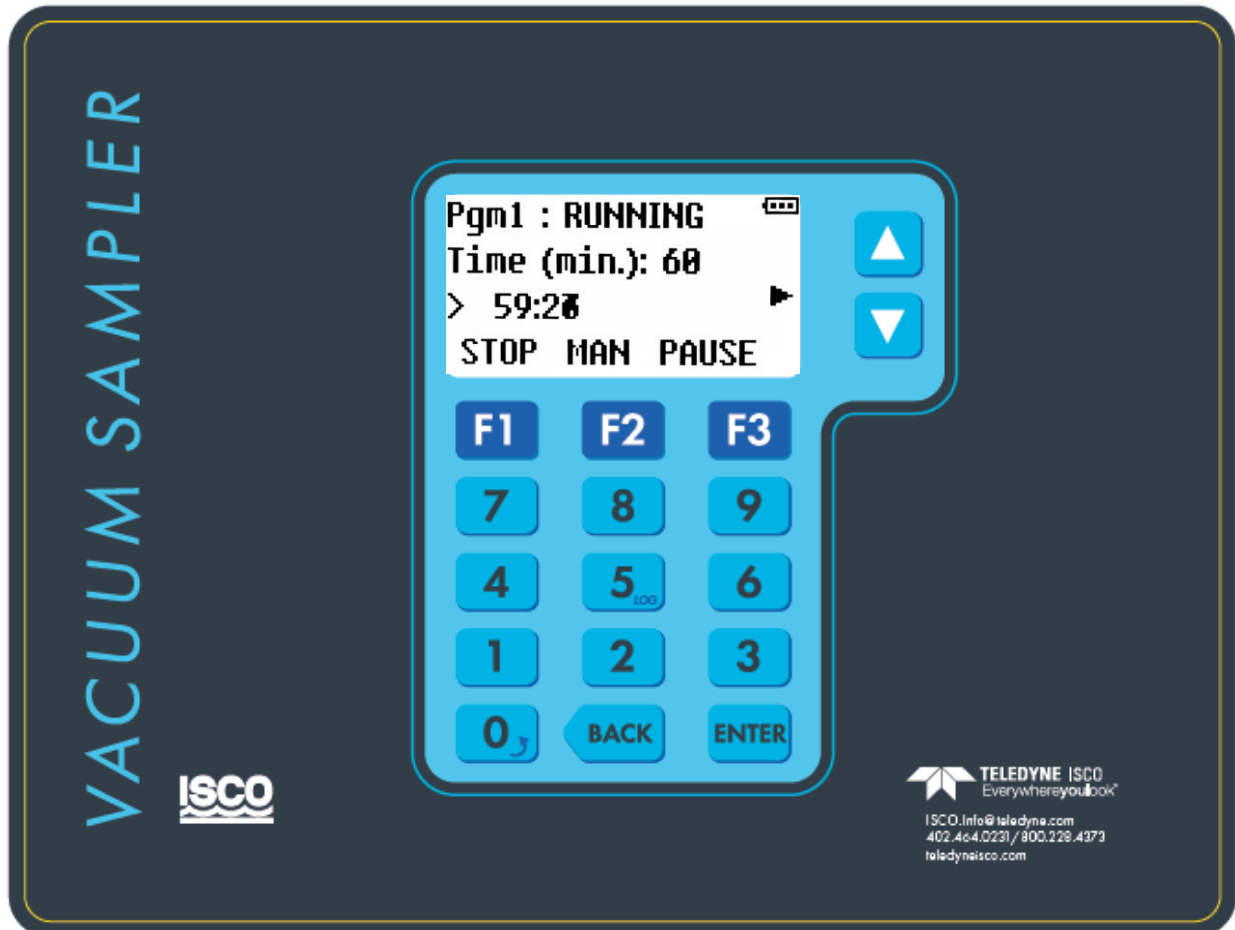

Figure 3-1: User Interface Panel

Its LCD readout displays the identity of the selected sampling program, which the operator can start and stop or pause and resume (see Chapter 5: Sampler Operation). It displays four lines of alphanumeric text, plus a column of status icons that might appear along its right edge:

- The top line identifies and displays that program's operating state. The second and third lines display sets of status information, which you can cycle through by pressing the UP and Down keys to the right of the LCD.
- The bottom line indicates the functions (if any) of the top three keys (F1, F2 and F3).
- Various status icons (see Table 5-1 Chapter 5) are displayed along the right edge of the readout (as you face it).
- *The display panel backlight will automatically turn off if no keyboard activity has been detected in the last two minutes. Pressing any key will then turn it back on.*

3.1: Control Buttons and Functions

Table 3-1: Control Buttons Table		
Icon	Name	Description
F1	HOME RUN STOP RESET ESC YES	Go to home screen Start the program Stop the program Reset the program Go back to previous menu Accept
F2	MAN TIMED GRAB BACK MORE	Manual sample Set a timed delay Grab sample Go back in the program See more detail in log file
F3	MENU SEL PAUSE RESTART START DETAIL CONTINUE NO	Go to menu Select Pause the program Restart a program Initiate sample View log detail Continue program Reject
Back		Press this button to back one space when entering a number.
Enter		Press this button to enter a number or to select a setting.
0-9	Keypad	Keypad enter number's

3.2: Menu System

The control system is set up and administered via a hierarchical menu (Appendix A.1.2) accessed by pressing the F3 key when the prompt above it reads “MENU”. If the administration password (Chapter 3.3.2) has its default value (0), the first Main Menu option will then be displayed:



If that password has a non-zero value, the Password entry screen will appear instead. Like many other menu screens, it assigns the HOME, BACK and SEL (select) functions to the F1, F2 and F3 keys:

- Pressing HOME [F1] generally displays the parent menu for the current screen. If you are editing settings, any changes you have made to the current parameter will not be saved.
- Pressing BACK [F2] or the **Back** (bottom row, center) key generally restores the previously-displayed screen or, if you are editing numerical parameter values, backspaces over the most-recently typed digit.
- Pressing SEL [F3] or the **Enter** (bottom row, right) key generally displays the next parameter or screen in a sequence. If you are editing settings, any changes you have made to the current parameter will be saved.

In this case, pressing HOME [F1] would restore the operating state display (as would BACK [F2] or the Back key before you start typing the password):



To access the Main Menu, use the numeric keys to type the correct password, and then press SEL [F3] or the Enter key. If the password was 56, for example:



Typing the first digit changes the F1 prompt to UNDO—pressing that key would then clear any digits you had typed so far and restore the initial Password screen. In contrast, pressing BACK [F2] or the Back key will clear only the last typed digit.

Note: Entering a password is not required to operate the control.

Whenever any Main Menu screen is displayed, you can scroll through its five options by pressing the Up or Down key, display the first option of the indicated subordinate menu by pressing SEL [F3] or the Enter key, or exit the menu system by pressing HOME [F1]:

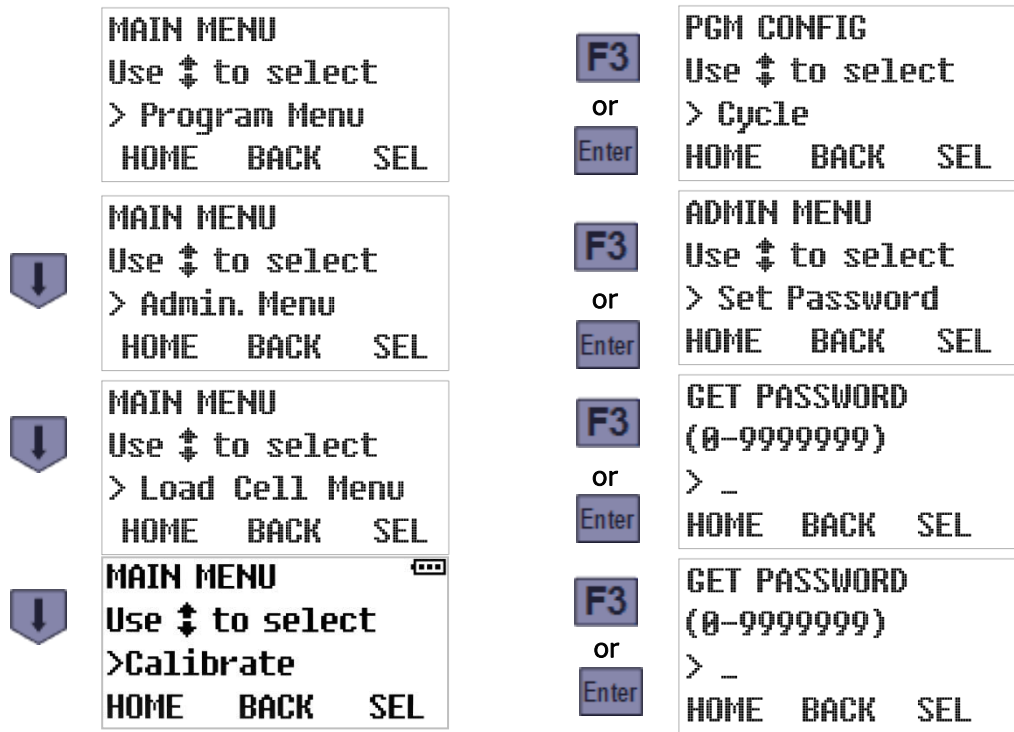

For convenience, each of those subordinate menus is set up so saving a setting (or initiating an action) automatically displays the next one. Also, pressing the Enter key (or SEL [F3], if available) when a setting's current value is first displayed leaves it unchanged. So you can advance through the entire menu, viewing but not changing any settings, by simply pressing the Enter key enough times.

- ⚠ Access to the Load Cell and Factory Menus, which are used to adapt each controller to its sampler prior to shipment, are restricted by additional passwords.



3.3: Administration Menu

Administration Menu screens can be used to:

- Set Language- change Languages (Chapter 3.2.1)
- Set Password- set a password (Chapter 3.2.2)
- Clr Password- allows you to clear the selected password
- Set DST- set time for daylight saving time
- Set Clock-set time and date (Chapter 3.2.3)
- Adjust LCD- adjust display contrast (Chapter 3.2.4)
- Download Archives- Downloading sampling data (not active at this time)
- Clear Archives- clear sampling data, the sampler will store the data for display viewing (Chapter 3.2.5)
- Set ID- sampler can be assigned ID number (Chapter 3.2.6)
- Set Units- set units English or Metric (Chapter 3.2.7)

1. Access the **Main Menu** by pressing the MENU [F3] key and (if so prompted) entering the optional password (see Menu System above).
2. Press the DOWN key to scroll to the **Administration Menu** option, then press the SEL [F3] or Enter key to display that menu's first option:

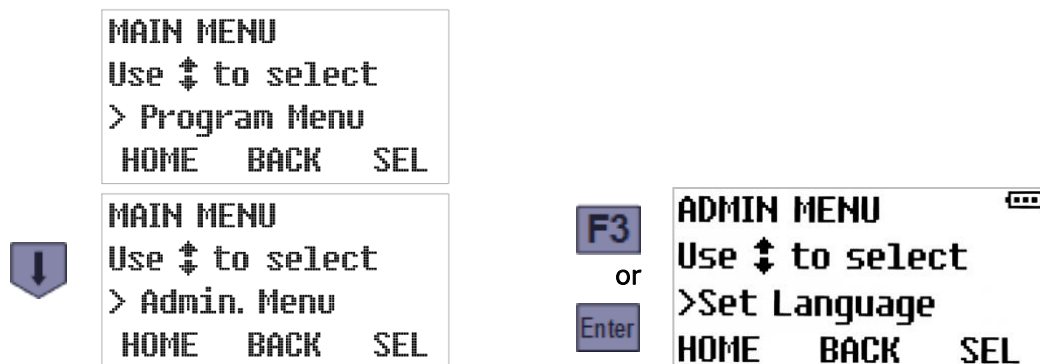

3.3.1: Set Language

Select this option to change the display language. Scroll through the menu using the up and down arrow to select the desired language. (English, German, French, Spanish, Italian, Polish, Danish, Sweden) Then push F3 (SEL) or Enter and the screen will advance to Change Language Yes or No. If the language change is correct select Yes, if incorrect press No. The unit of measure can be changed in > Set Units which is also in the ADMIN MENU.

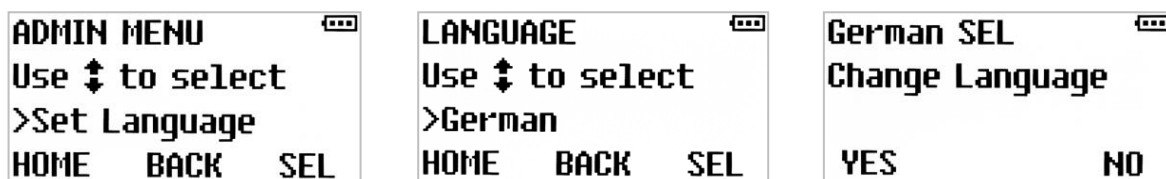

3.3.2: Administration Password

The **administration password** can be used to prevent unauthorized individuals from accessing the Administration and Program menus. Entering a Password is not required.

- If it is set to zero (its factory default value), pressing the MENU [F3] key will immediately display the first Main Menu option.
- If it is assigned a value from 1 to 9,999,999 (leading zeroes are not allowed), pressing MENU[F3] will display the Password entry screen.

⚠ The Load Cell and Factory Menus, which are meant to be used only by Teledyne ISCO personnel, are protected by additional passwords that must be entered even if the administration password is cleared (set to zero).

⚠ If you forget the value of your administration password, contact Teledyne ISCO for instructions on how to regain access to your sampler menu system or use the override password 951753.

To change the administration password's value:

1. Select the Administration menu (Chapter 3.2) to display its second option (Set Password). The second line of the readout will then show the range of allowable values while the third displays the current password:

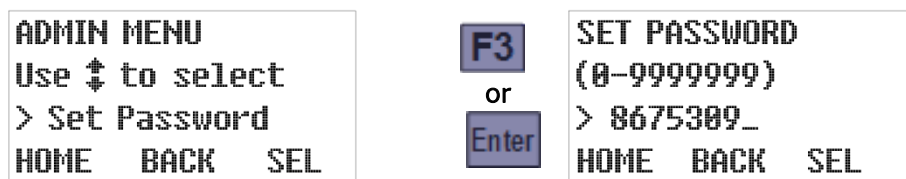

2. Type the new password by pressing the corresponding numeric keys (the old password will be erased and the F1 prompt will change from HOME to UNDO). Then press the SEL [F3] or Enter key to save the displayed password and advance to the next Administration Menu option. To change it to 56, for example, just press 5, then 6, and finally SEL [F3] or Enter. The new value will then be saved and the next Admin Menu option will be displayed:



While entering a new password:

- Pressing UNDO[F1] would restore the old password value.
- Pressing BACK [F2] or the Back key would delete the right-most typed digit. Backspacing over the first digit will restore the old password.

Setting the password to zero (0) removes any previously set Administration and Program Menu protection. An easier way to do that, however, is to execute the second Admin Menu option:

1. Select the Administration Menu (see page 31) and press the DOWN key to display its Clear Password option.
2. Press the SEL[F3] or Enter key to immediately set the password to zero. A STATUS UPDATE screen will appear briefly, followed by the next Administration Menu option:

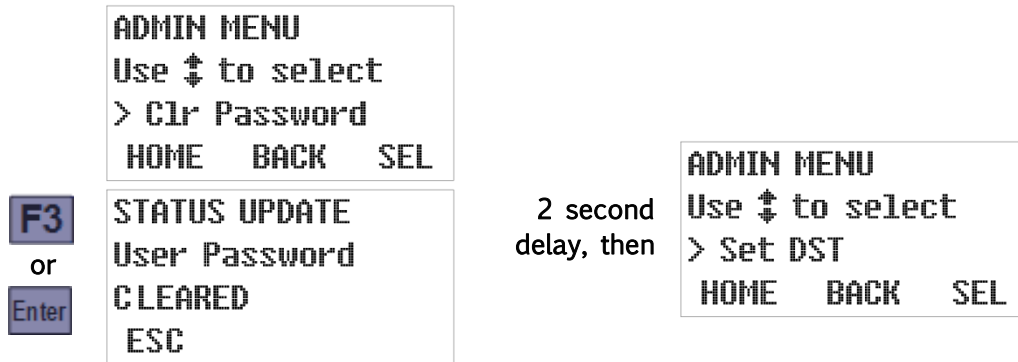

3.3.3: Clock Settings

The control board includes a real-time clock chip with a backup battery, so it runs even when the control board is powered down. This enables it to timestamp all archived data and to collect samples at scheduled times. In addition, the current time and date are displayed on the third line of the second operating status screen.

The third Administration Menu option allows you to quickly adjust the clock by one hour when daylight savings time (DST) begins or ends, while the fourth allows you to directly reset the clock to the current date and time. Because you should make sure the DST option is correct before setting the time, those options should be executed in the order presented:

Select the Administration Menu (Chapter 3.2), use the Down key to scroll to its third (Set DST) option, and then press the SEL [F3] or Enter key. The third line of the readout will then show the current daylight savings time setting:

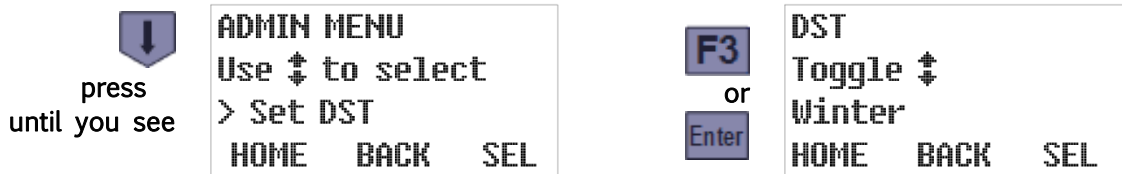

1. If necessary, press either the Up or the Down key to toggle that setting. When the desired setting is displayed, press the SEL [F3] or Enter key to save it and display the Set Clock option:



2. To adjust the date and time settings, press the SEL [F3] or Enter key. Otherwise, scroll to another Administration Menu option or press the HOME [F1] key to restore the Main Menu.

The current date setting is displayed first. If it is correct, or after you have corrected it, press the Enter key to save the displayed date and access the current time setting:



The same techniques are used to change both settings. The third line displays the current value, with an underline cursor indicating the digit currently subject to editing:

- Press the Previous [F2] or Next [F3] key to move that cursor one digit left or right.
- Press any appropriate numeric key to set the current digit and advance the cursor OR press the Up or Down key to increment or decrement the current digit.
- Press the ESC[F1] key to undo any change to the displayed setting and return to the Administration Menu/Set Clock screen.

3. Pressing the Enter key while the time setting is displayed saves that time and displays the next Administration Menu option:

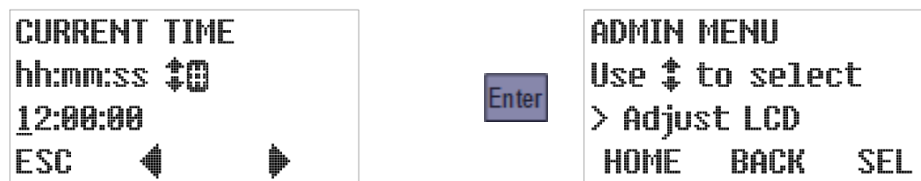

3.3.4: LCD Brightness

To adjust the brightness of the LCD backlight:

1. Select the Administration Menu (Chapter 3.2), use the Up or Down key to scroll to its fifth (Adjust LCD) option, and then press the SEL [F3] or Enter key to display the current setting:

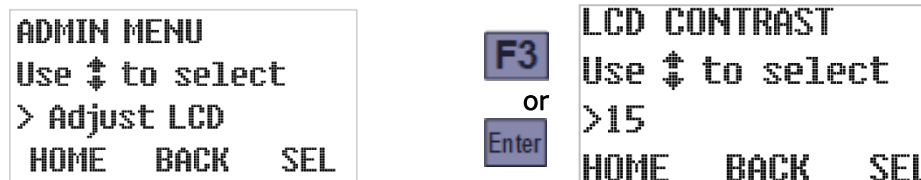

2. Pressing the Up or Down key will increment or decrement that setting while making the screen slightly brighter or darker. The darkest possible setting is 0, the brightest is 30:



3. Pressing the SEL [F3] or Enter key saves the displayed setting and displays the next Administration Menu option.

3.3.5: Archival Data Administration

To erase those log files from the microprocessor’s memory, select the Administration Menu. Then use the Up or Down key to scroll to its seventh (Clear Archive) option, and press the SEL [F3] or Enterkey:

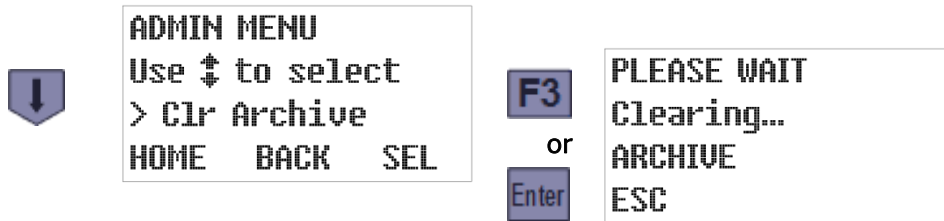

3.3.6: Set ID Number

Each sampler can be assigned a unique ID number. To set it:

1. Select the Administration Menu , use the Down key to scroll to its Set ID option, and then press the SEL [F3] or Enter key to display the current ID:



2. Type the new ID by pressing the corresponding numeric keys, then press the SEL[F3] or Enter key to save it and advance to the next Administration Menu option:



3.3.7: Set Units (Volumetric)

Each sampler can be configured on-the-fly to display flow volumes and composite bottle sizes in either English or metric units (e.g., gallons or liters). To do so:

1. Select the Administration Menu (Chapter 3.2), use the Up key to scroll to its Set Units option, and then press the SEL [F3] or Enter key to display the currently selected option:

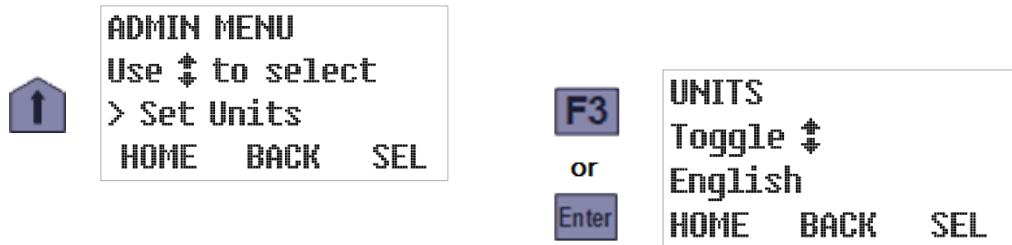

2. Press the Up or Down key to toggle to this option's alternate value. Then press the SEL [F3] or Enter key to save the displayed setting and advance to the next Administration Menu option: The screen returns to Set Language, to exit push HOME (F1).



Chapter 4: Sampling Program Configuration

Each user interface panel's **Program Menu** is used to configure that controller's Sampling Programs (see Appendix A:) and specify which is selected to be configured and/or started. Although you can directly view and change individual parameters for each program, the menu is designed so that all parameters for each program can be set in one continuous process:

- Each program's parameters are divided into several configuration groups.
- Selecting a specific program displays the first parameter in its first group.
- Pressing the SEL[F3] or Enter key (whether or not you have changed the displayed value) displays the next parameter in the same group.
- Options that are rendered inapplicable by those you have already set are not displayed.
- Setting the last parameter in any group returns you to the Program Configuration menu with the next parameter group selected.

In other words, simply access the Program Menu, select the program you want to configure, and then keep pressing the SEL [F3] or Enter key as you verify or change each setting.

4.1: Program Selection

Access the **Main Menu** by pressing the MENU [F3] key and (if so prompted) entering the optional password. The **Program Menu** should be the first Main Menu option—if not, use the Up or Down key to scroll to that option. Then press the SEL [F3] or Enter key to display the Program Select screen:

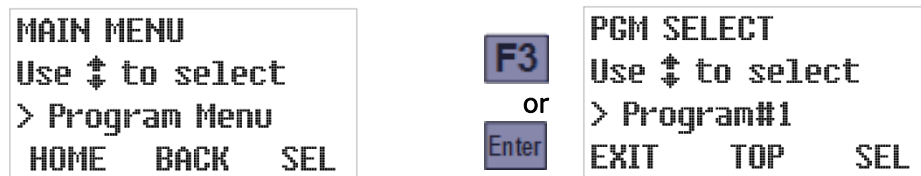

Use the Up or Down key to scroll to the program you want, then press the SEL [F3] or Enter key to select it and display the Program Configuration menu.

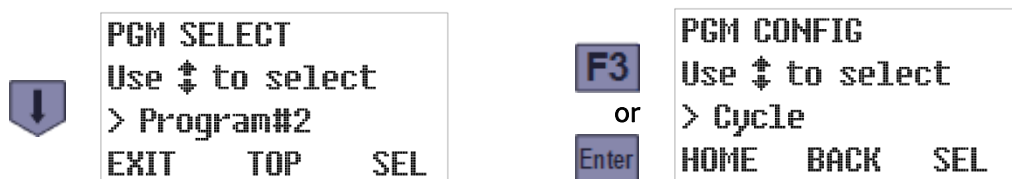

If that program has already been configured and you are just selecting it to be run, press HOME [F1] twice (or BACK [F2] or the Back key three times) to return to the Ready screen:



Otherwise, you can configure the selected program by setting the parameters in each of its five configuration groups (see next section).

4.2: Program Configuration Groups

The configuration parameters for each program are divided into five groups:

- Sampling Cycle Settings (Chapter 4.3)
- Sampling Intervals (Chapter 4.4)
- Bottle Options (Chapter 4.5)
- Run Options (Chapter 4.6)
- Program Events (Chapter 4.7)

To access a particular group, select the program you want to configure (see above) to display its Program Configuration menu. Use the Up or Down key to scroll to the parameter group of interest, then press the SEL [F3] or Enter key to display that group's first setting:

	<pre>PGM CONFIG Use ↑↓ to select >Cycle HOME BACK SEL</pre>	<pre>F3 or Enter</pre>	<pre>PREPURGE (0-99 sec.) > 15_ HOME BACK SEL</pre>
↓	<pre>PGM CONFIG Use ↑↓ to select >Smpl. Interval HOME BACK SEL</pre>	<pre>F3 or Enter</pre>	<pre>SMPL. INTERVAL Use ↑↓ to select >Time HOME BACK SEL</pre>
↓	<pre>PGM CONFIG Use ↑↓ to select >Bottle Opts. HOME BACK SEL</pre>	<pre>F3 or Enter</pre>	<pre>SAMPLE TYPE Use ↑↓ to select >Composite HOME BACK SEL</pre>
↓	<pre>PGM CONFIG Use ↑↓ to select >Pgm. Run Opts. HOME BACK SEL</pre>	<pre>F3 or Enter</pre>	<pre>AUTO RERUN Toggle ↑↓ >Enable HOME BACK SEL</pre>
↓	<pre>PGM CONFIG Use ↑↓ to select >Pgm. Events HOME BACK SEL</pre>	<pre>F3 or Enter</pre>	<pre>PGM EVENT #1 Use ↑↓ to select >End List HOME BACK SEL</pre>

You can return to the Program Configuration menu from any parameter screen by pressing the HOME [F1] key, and then to the Program Selection screen by pressing the BACK [F2] key:

F1	<pre>PGM CONFIG Use ↑↓ to select >Cycle HOME BACK SEL</pre>	F2	<pre>PGM SELECT Use ↑↓ to select > Program#1 EXIT TOP SEL</pre>
-----------	--	-----------	--

4.3: Sampling Cycle Settings

This group includes the parameters that configure the sampling cycle (Chapter 4.3).

- pre-sampling purge duration (Chapter 4.3.1)
- sample size (Chapter 4.3.2)
- post-sampling purge duration (Chapter 4.3.3)
- line conditioning rinses (Chapter 4.3.4)
- incomplete sample recycling (Chapter 4.3.5)
- consecutive sampling (Chapter 4.3.6)

To access those parameters, select the program you want to configure (Chapter 4.1) and press the SEL [F3] or Enter key to display its first parameter group (Cycle). Then press the SEL [F3] or Enter key again to display that group's first setting:

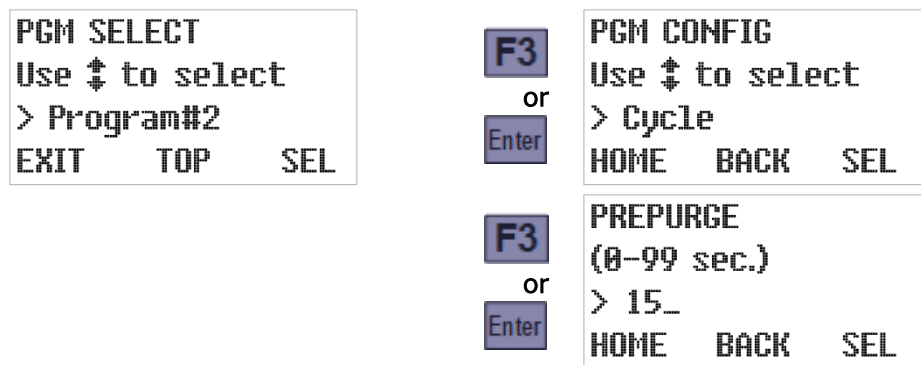

4.3.1: Pre-Sampling Purge Duration

This parameter specifies the number of seconds the chamber will be pressurized to clear the sampling tube prior to drawing a sample. To determine and optionally change its value:

1. Select the Cycle parameter group to display this parameter's current value (see above).
2. If desired, type a new pre-purge duration by pressing the corresponding numeric keys. When you type the first digit, the old value is erased and the F1 prompt changes from HOME to UNDO. You can then press the UNDO [F1] key to start over, or the BACK [F2] or Back key to delete the most-recently typed digit.
3. Press the SEL [F3] or Enter key to save the displayed value (changed or not) and advance to the next Sampling Cycle group parameter.

To change the pre-purge duration to 20 seconds, for example:



4.3.2: Sample Size

This parameter specifies the intended size of each sample in milliliters. To determine and optionally change its value:

1. Accept or change the Pre-purge Duration, which will display this parameter's current value.
2. If desired, type a new sample size by pressing the corresponding numeric keys. When you type the first digit, the old value is erased and the F1 prompt changes from HOME to UNDO. You can then press the UNDO [F1] key to start over, or the BACK [F2] or Back key to delete the most-recently typed digit.
3. Press the SEL [F3] or Enter key to save the displayed value (changed or not) and advance to the next Sampling Cycle group parameter.

To change the sample size to 100 ml, for example:



If the new sample size triggers an automatic reduction in the configured number of samples per bottle the following screen will briefly appear:

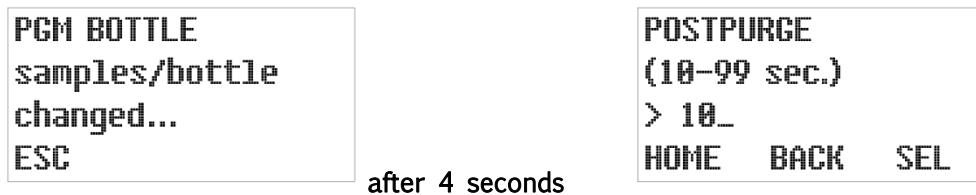

4.3.3: Post-Sampling Purge Duration

This parameter specifies the number of seconds the chamber will be pressurized after each sample is drawn, in order to reverse the fluid flow and clear the sampling tube prior to weighing the samples. To determine and optionally change its value:



1. Accept or change the Sample Size, which will display this parameter's current value.
2. If desired, type a new post purge duration by pressing the corresponding numeric keys. When you type the first digit, the old value will be erased and the F1 prompt will change from HOME to UNDO. You can then press the UNDO [F1] key to start over, or the BACK [F2] or Back key to delete the most-recently typed digit.
3. Press the SEL [F3] or Enter key to save the displayed value (changed or not) and advance to the next Sampling Cycle group parameter.

4.3.4: Line Conditioning Rinses

This feature can be configured to rinse out the intake line up to four times prior to drawing each sample. To enable it, specify a non-zero number of rinses and then set its pressure and vacuum phase durations:

1. View/change the Post purge Duration and then press the SEL [F3] or Enter key to display the currently-specified number of rinses (see above).
2. Type the desired value by pressing the corresponding numeric key. Then press the SEL [F3] or Enter key to save the displayed number of rinses:
 - Setting it to 0 disables this feature, in which case the screens for setting its pressure and vacuum phase durations will not be displayed:



- Setting it to any other value would display the current pressure phase duration:

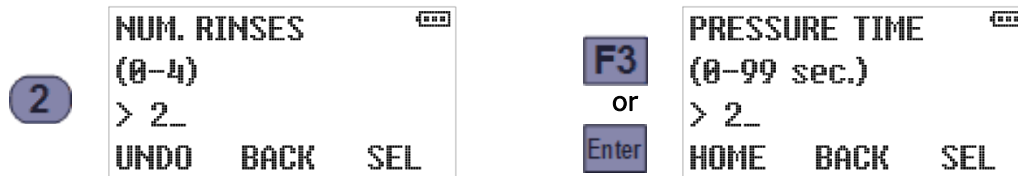

3. Type the new pressure time by pressing the corresponding numeric keys. Then press the SEL [F3] or Enter key to save the displayed pressure time and display the current vacuum phase duration:

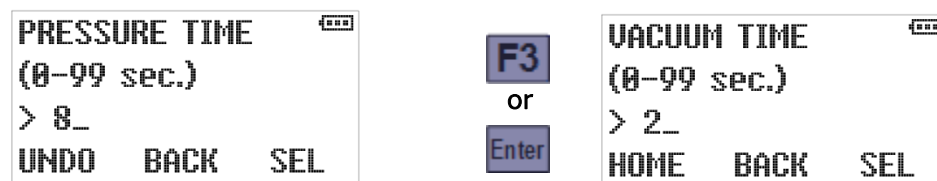

4. Type the new vacuum time by pressing the corresponding numeric key. Then press the SEL [F3] or Enter key to save the displayed vacuum time and advance to the next Sampling Cycle group parameter:

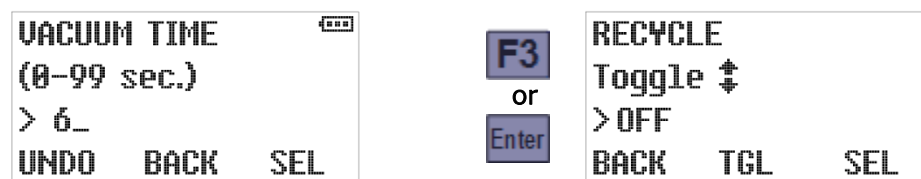

⚠

*The vacuum phase should be brief enough that no water is drawn into the sampling chamber. If water enters the sampling chamber during the rinse cycle a **Rinse Error** will be displayed and the program will stop. The vacuum time in the rinse cycle needs to be reduced so sample does not enter the sample chamber.*

4.3.5: RECYCLE- (Sample Retry)

If this feature is enabled, the controller will “recycle” the collection of incomplete (less than 60 percent of the configured size) samples by repeating the sampling cycle (except for initializing and zeroing the load cell) as many as four times. To enable or disable it:

1. View/change the rinse settings and then press the SEL [F3] or Enter key to display the current status of this feature.
2. You can enable this feature by pressing the 1 key, disable it by pressing the 0 key, or toggle its status by pressing the TGL[F2], Up or Down key.
3. Press the SEL [F3] or Enter key to save the displayed status and advance to the next Sampling Cycle group parameter.



4.3.6: Consecutive Sampling

This parameter specifies the number of samples to be drawn at the end of each time or flow interval. If you set it to more than one, the full sampling cycle (including recycling if needed) will be repeated the specified number of times for each interval.

You might want to specify more than one and configure appropriate or either of two reasons:

- Drawing several samples one after the other and discharging them to the same container effectively allows you to collect samples larger than the 500 ml maximum size.
- Drawing consecutive samples and discharging them to different containers allows you to save and process duplicate samples for verification purposes.

To view/change the number of samples to be drawn per interval:

1. View/change the recycling settings and then press the SEL [F3] or Enter key to display the current value of this parameter.
2. Type the new value by pressing the corresponding numeric keys. Then press the SEL[F3] or Enter key to save the displayed value and return to the Program Configuration menu scrolled to the next parameter group.

To configure a sample to draw two samples per interval, for example:



4.4: Sampling Intervals

This group includes one main parameter that specifies the type of sampling interval(s) the controller will use, and several parameter groups that configure those interval(s).

To directly access the sampling interval type, select the program you want to configure then press the Down key to scroll to the Sample Intervals group:

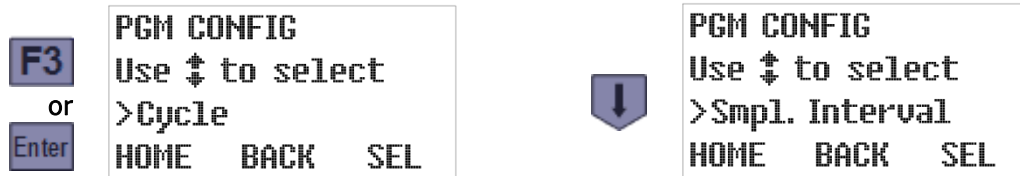

Press the SEL [F3] or Enter key to display the currently-configured interval type, then use the Down or Up key to scroll to the desired new setting. With that value displayed, press the SEL [F3] or Enter key to display the first parameter for that interval type:

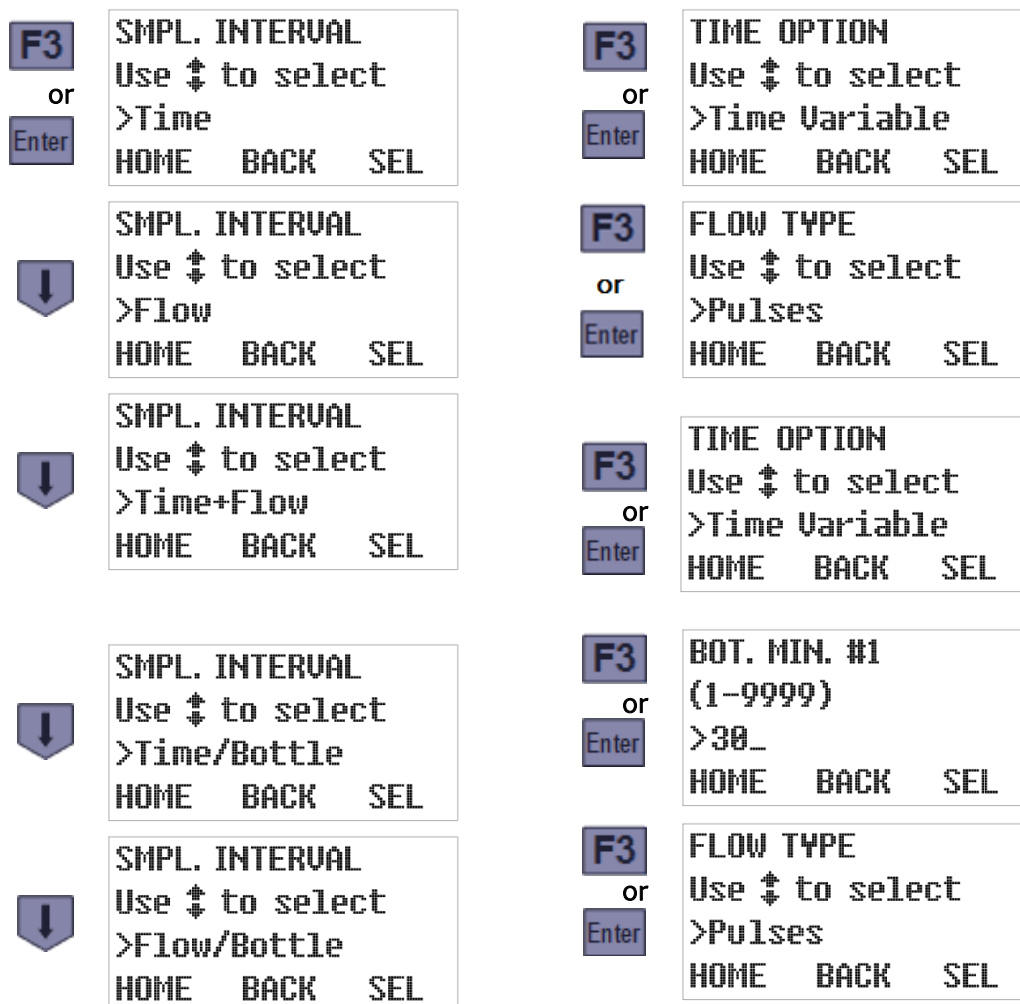

The “per bottle” options will appear only if your controller is equipped with the multiple-bottle turntable and factory-configured to display the discrete-sampling bottle options.

4.4.1: Timed Interval Sampling

Selecting the **Time** sampling interval option configures the controller to wait a specified number of minutes after initiating one sample before initiating the next:

- If the samples are to be drawn at regular intervals, select the **Time Fixed** option and then set the fixed length of those intervals. For example, you might configure a program to draw samples every 60 minutes until it is stopped.
- Otherwise, select the **Time Variable** option and then specify no more than 24 time intervals. One sample will be drawn at the end of each specified interval, after which the last interval will be repeated until the program is stopped. For example, you might configure a program to draw its first sample an hour after starting and then switch to 30 minute intervals.

To select the desired option:

1. Scroll the Sample Interval parameter’s value to Time (see above), then press the SEL [F3] or Enter key to save that value and display the currently-selected Time Option:

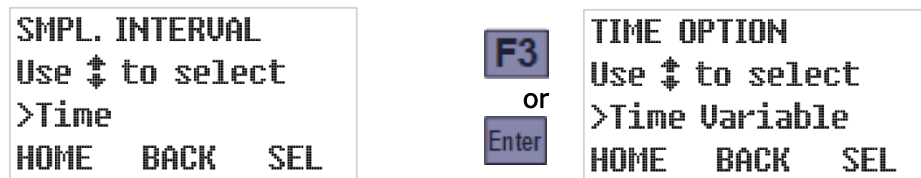

2. Use the Up or Down key to toggle between that parameter’s two possible values, then press the SEL [F3] or Enter key to save the displayed value and display its first setting:

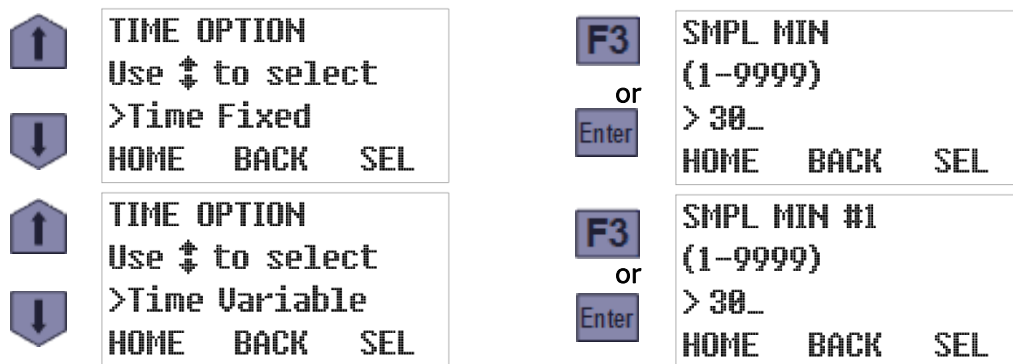

4.4.1.1: Fixed Length Time Intervals

As shown above, selecting the **Time Fixed** option displays its first (and only) parameter—the length of time it waits between initiating any sample and the next. To change it, type the new duration (20 minutes, for example) by pressing the corresponding numeric keys. Then press the SEL [F3] or Enter key to save the displayed Sample Minutes (changed or not) and display the Program Configuration menu’s Bottle Options screen:



4.4.1.2: Variable Length Time Intervals

As shown previously, selecting the **Time Variable** option displays the first of 24 Sample Minutes parameters—the length of time it will wait before drawing its first sample. To change its value, type the new duration (20 minutes, for example) by pressing the corresponding numeric keys. Press the SEL[F3] or Enter key to save that value (changed or not) and display the next:

<div style="border: 1px solid black; border-radius: 50%; width: 30px; height: 30px; display: flex; align-items: center; justify-content: center; margin: 5px;">2</div> <div style="border: 1px solid black; border-radius: 50%; width: 30px; height: 30px; display: flex; align-items: center; justify-content: center; margin: 5px;">0</div>	<p>SMPL MIN #1 (1-9999) > 20_ UNDO BACK SEL</p>	<div style="border: 1px solid black; padding: 2px; width: 30px; height: 30px; display: flex; align-items: center; justify-content: center; margin: 5px;">F3</div> <p>or</p> <div style="border: 1px solid black; padding: 2px; width: 30px; height: 30px; display: flex; align-items: center; justify-content: center; margin: 5px;">Enter</div>	<p>SMPL MIN #2 (0-9999)0-end > 60_ HOME BACK SEL</p>
---	--	--	---

The digit keys can then be used to change the number of minutes the program would wait between initiating its first and second samples. Pressing the SEL[F3] or Enter key would again save the displayed value and display the next. And so on until pressing the SEL [F3] or Enter key while Sample Minutes #24 is displayed restores the Program Configuration menu scrolled to its next group (Bottle Options).

<div style="border: 1px solid black; border-radius: 50%; width: 30px; height: 30px; display: flex; align-items: center; justify-content: center; margin: 5px;">6</div> <div style="border: 1px solid black; border-radius: 50%; width: 30px; height: 30px; display: flex; align-items: center; justify-content: center; margin: 5px;">0</div>	<p>SMPL MIN #24 (1-9999)0-end > 60_ UNDO BACK SEL</p>	<div style="border: 1px solid black; padding: 2px; width: 30px; height: 30px; display: flex; align-items: center; justify-content: center; margin: 5px;">F3</div> <p>or</p> <div style="border: 1px solid black; padding: 2px; width: 30px; height: 30px; display: flex; align-items: center; justify-content: center; margin: 5px;">Enter</div>	<p>PGM CONFIG Use ↑ to select > Bottle Opts. HOME BACK SEL</p>
---	--	--	---

However, you do not need to set all 24 intervals—setting any one of them to 0 configures the program to use the value of the preceding parameter for all subsequent intervals. For example, setting Sample Minutes #5 to 120 and Sample Minutes #6 to 0 would have the same effect as setting Sample Minutes #6 through #24 all to 120 (the value of Sample Minutes #5):

<div style="border: 1px solid black; border-radius: 50%; width: 30px; height: 30px; display: flex; align-items: center; justify-content: center; margin: 5px;">1</div> <div style="border: 1px solid black; border-radius: 50%; width: 30px; height: 30px; display: flex; align-items: center; justify-content: center; margin: 5px;">2</div> <div style="border: 1px solid black; border-radius: 50%; width: 30px; height: 30px; display: flex; align-items: center; justify-content: center; margin: 5px;">0</div>	<p>SMPL MIN #5 (0-9999)0-end > 120_ UNDO BACK SEL</p>	<div style="border: 1px solid black; padding: 2px; width: 30px; height: 30px; display: flex; align-items: center; justify-content: center; margin: 5px;">F3</div> <p>or</p> <div style="border: 1px solid black; padding: 2px; width: 30px; height: 30px; display: flex; align-items: center; justify-content: center; margin: 5px;">Enter</div>	<p>SMPL MIN #6 (0-9999)0-end > 150_ HOME BACK SEL</p>
<div style="border: 1px solid black; border-radius: 50%; width: 30px; height: 30px; display: flex; align-items: center; justify-content: center; margin: 5px;">0</div>	<p>SMPL MIN #6 (0-9999)0-end > 0_ UNDO BACK SEL</p>	<div style="border: 1px solid black; padding: 2px; width: 30px; height: 30px; display: flex; align-items: center; justify-content: center; margin: 5px;">F3</div> <p>or</p> <div style="border: 1px solid black; padding: 2px; width: 30px; height: 30px; display: flex; align-items: center; justify-content: center; margin: 5px;">Enter</div>	<p>PGM CONFIG Use ↑ to select > Bottle Opts. HOME BACK SEL</p>

4.4.2: Flow Interval Sampling

Selecting the **Flow** sampling interval option configures the controller to initiate sampling as its accumulated flow measurement increases by specified volumes. You must then:

- Select the flow input type (4-20 mA, 0-5 Vdc, 0-10 Vdc, or discrete pulse).
- Specify the flow rate corresponding to the maximum signal (analog input only).
- Specify the incremental flow between the initiation of one sample and the next:
 - If the samples are to be drawn at regular intervals (for example, after each 5000 gallon flow increment), select the **Flow Fixed** option and set the fixed length of those intervals.
 - Otherwise, select the **Flow Variable** option and specify no more than 24 flow intervals. One sample will be drawn at the end of each specified interval, after which the last interval will be repeated until the program is stopped. For example, you might configure a program to draw its first sample when the total flow reaches 5000 gallons, and then switch to 2500 gallon intervals (i.e., after 7500, 10000 and so on total gallons).

Flow volumes are specified in either gallons or liters, depending on the current Administration Menu Set Units setting (Chapter 3.2.7).

To specify the input type, scroll the Sample Interval parameter's value to Flow, then press the SEL [F3] or Enter key to save that value and display the currently-selected Flow Type:

<pre>SMPL. INTERVAL Use ↑↓ to select >Flow HOME BACK SEL</pre>	<p>F3 or Enter</p>	<pre>FLOW TYPE Use ↑↓ to select >Pulses HOME BACK SEL</pre>
---	--	--

Use the Up or Down key to scroll to the desired type, then press the SEL [F3] or Enter key to save it and display its first setting:

<pre>FLOW TYPE Use ↑↓ to select >4-20 mA HOME BACK SEL</pre>	<p>F3 or Enter</p>	<pre>MAX. GPM (1-500000) >5000_ HOME BACK SEL</pre>
<pre>FLOW TYPE Use ↑↓ to select >0-5 V HOME BACK SEL</pre>	<p>F3 or Enter</p>	<pre>MAX. GPM (1-500000) >5000_ HOME BACK SEL</pre>
<pre>FLOW TYPE Use ↑↓ to select >0-10 V HOME BACK SEL</pre>	<p>F3 or Enter</p>	<pre>MAX. GPM (1-500000) >5000_ HOME BACK SEL</pre>
<pre>FLOW TYPE Use ↑↓ to select >Pulses HOME BACK SEL</pre>	<p>F3 or Enter</p>	<pre>FLOW OPTION Use ↑↓ to select >Pulses Fixed HOME BACK SEL</pre>

4.4.2.1: Analog Flow Input

If you select one of the analog inputs types (4-20 mA, 0-5 VD, or 0-10 VDC), samples will be initiated an integer number of gallons apart. Thus, you must specify the flow rate (in gallons per minute) corresponding to the transmitter's maximum signal, after which you can specify the sampling intervals in gallons:

1. Select the flow input type (as described above) to display the current maximum flow rate setting (the rate at which the transmitter would transmit its maximum signal). This example shows the 0-10 VDC option, but the resulting screen would be the same for the 0-5 VDC or 4-20 mA options as well:

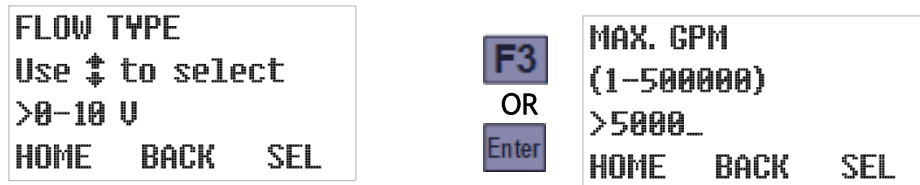

2. To change that setting, type a new maximum flow rate by pressing the corresponding numeric keys. When you type the first digit, the old value will be erased and the F1 prompt will change from HOME to UNDO. You can then press the UNDO [F1] key to start over, or the BACK[F2] or Back key to delete the most-recently typed digit.
3. Press the SEL [F3] or Enter key to save the displayed value (changed or not) and display the current flow option (fixed or variable sampling intervals). As an example:



The above example assumes you are using a flow transmitter whose signal varies from 0 VDC at no flow up to 10 VDC at 1500 gallons per minute. A 1.0 VDC signal would then indicate the flow was 150 GPM, so the controller would then calculate the instantaneous flow by multiplying 150 by the input signal in volts.

4. Use the Up or Down key to toggle between the Flow Option's two possible values, then press the SEL [F3] or Enter key to save the displayed value and display its first setting:

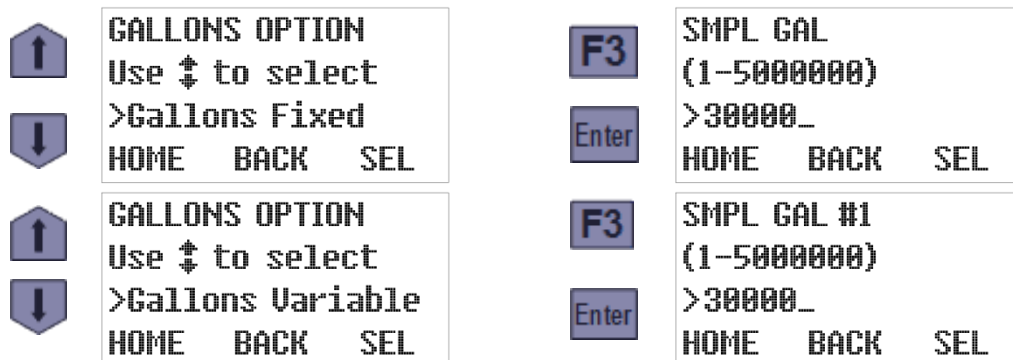

4.4.2.1.1: Fixed Volume Flow Intervals

As shown previously, selecting the **Flow Fixed** option displays its only parameter—the specified change in flow between samples. To change that interval, type a new value by pressing the corresponding numeric keys. Then press the SEL [F3] or Enter key to save the displayed Sample Gallons (changed or not) and display the Program Configuration menu’s next screen:



4.4.2.1.2: Variable Volume Flow Intervals

As shown previously, selecting the **Flow Variable** option displays the first of 24 Sample Gallons parameters—the incremental flow at which the controller will draw its first sample. To change it, type the new flow increment (2400 gallons, for example) by pressing the corresponding numeric keys. Press the SEL [F3] or Enter key to save that value (changed or not) and display the next:



The digit keys can then be used to change the number of gallons the program would measure between initiating its first and second samples. Pressing the SEL [F3] or Enter key would again save the displayed value and display the next. And so on until pressing the SEL [F3] or Enter key while Sample Gallons #24 is displayed restores the Program Configuration menu scrolled to its next group (Bottle Options):



However, you do not need to set all 24 intervals—setting any one of them to 0 configures the program to use the value of the preceding parameter for all subsequent intervals. For example, setting Sample Gallons #5 to 4000 and Sample Gallons #6 to 0 would have the same effect as setting Sample Gallons #6 through #24 all to 4000 (the value of Sample Gallons #5):

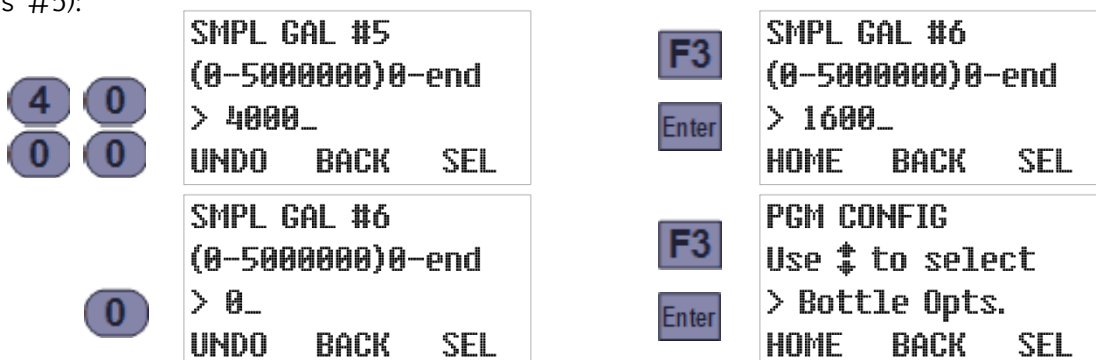

4.4.2.2: Pulsing Flow Input

The pulse flow type is for meters that transmit discrete pulses at specific flow intervals. For example, a meter that sends one pulse for every 100 gallons of flow will transmit its first pulse when the total flow it has measured reaches 100 gallons, a second at 200 gallons, and so on.

When this flow type is selected, you must configure the controller to draw samples at intervals that are an integer number of pulses apart (which correspond to the flow increments at which you really want it to draw samples):

1. Select the pulse flow type (Chapter 4.4.2) to display the current value of the flow option (fixed or variable intervals):

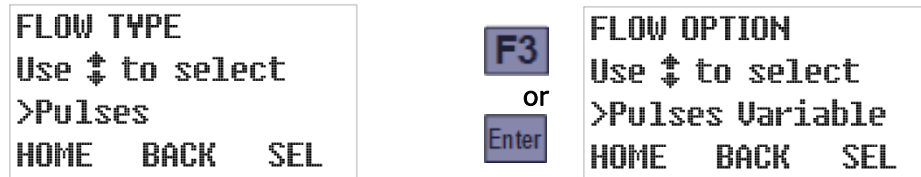

2. Use the Up or Down key to toggle between that parameter's two possible values, then press the SEL [F3] or Enter key to save the displayed value and display its first setting:

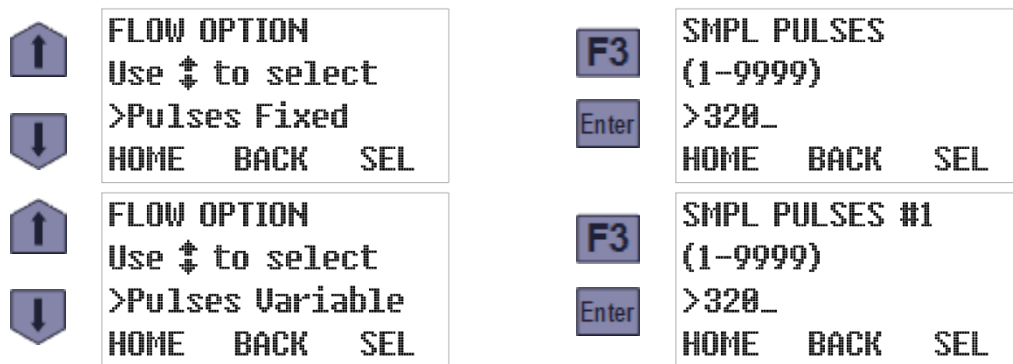

4.4.2.2.1: Fixed Pulses Flow Intervals

As shown above, selecting the **Pulses Fixed** option displays its only parameter—the specified number of input pulses between samples. To change that setting, type the new interval pulse count (240, for example) by pressing the corresponding numeric keys. Then press the SEL [F3] or Enter key to save the displayed Sample Pulses (changed or not) and display the Program Configuration menu's next screen:



You can repurpose the flow-pulse input to initiate a sample each time a connected PLC or other external device closes its circuit (Appendix A. 2.5). In that case, you would of course set this parameter to 1.

4.4.2.2.2: Variable Pulses Flow Intervals

Selecting the **Pulses Variable** option displays the first of 24 Sample Pulses parameters—the number of pulses at which the controller will draw its first sample. To change it, type the new first sample pulse count (240, for example) by pressing the corresponding numeric keys. Press the SEL[F3] or Enter key to save that value (changed or not) and display the next:



The digit keys can then be used to change the number of pulses the program would wait between initiating its first and second samples. Pressing the SEL [F3] or Enter key would again save the displayed value and display the next. And so on until pressing the SEL [F3] or Enter key while Sample Pulses #24 is displayed restores the Program Configuration menu scrolled to its next group (Bottle Options):

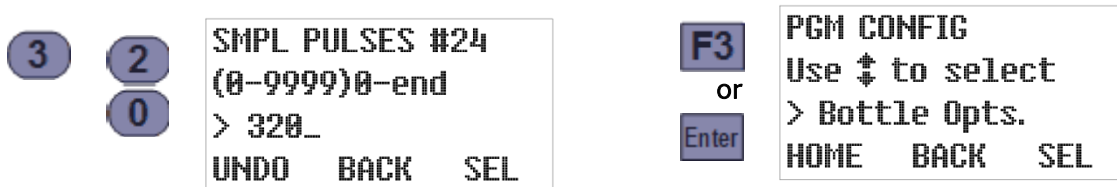

However, you do not need to set all 24 intervals—setting any one of them to 0 configures the program to use the value of the preceding parameter for all subsequent intervals. For example, setting Sample Pulses #5 to 400 and Sample Pulses #6 to 0 would have the same effect as setting Sample Pulses #6 through #24 all to 400 (the value of Sample Pulses #5):

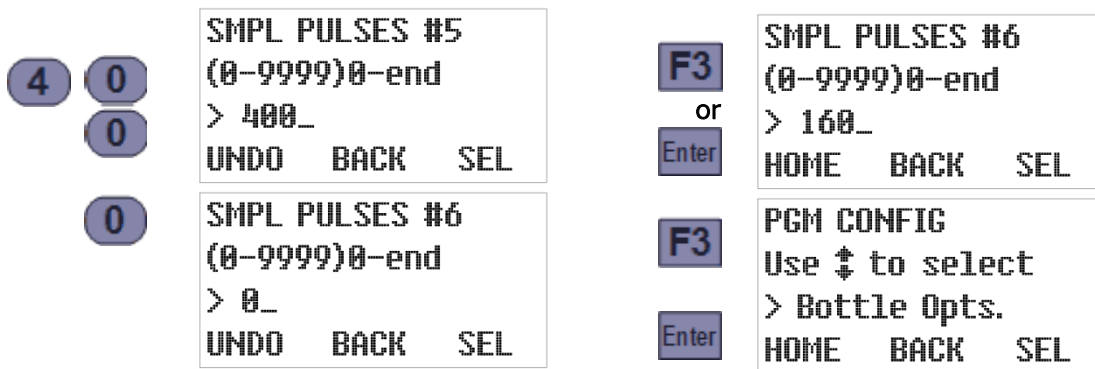

4.4.3: Time and Flow Interval Sampling

Selecting the **Time+Flow** sampling interval option configures the controller to draw samples at either time or flow intervals, which ever proves to be the soonest for each sample. In other words, it accumulates both the time and the flow since the last sample was initiated and initiates the next (and resets both counters) as soon as either reaches its configured target.

When this option is selected, you will be prompted to:

1. Select the Time Option and set its associated parameters (Chapter 4.4.1), and then
2. Select the Flow Type and Option and set their associated parameters (Chapter 4.4.2).

4.4.4: Per-Bottle Timed Interval Sampling

Selecting a sequential sampler’s **Time/Bottle** interval option configures it to draw samples at time intervals that are tied to the rotation of the bottle carousel.

To configure this option, scroll the Sample Interval parameter to Time/Bottle (Chapter 4.4), then press the SEL [F3] or Enter key to save that choice and display the first of its 24 Bottle Minutes parameters—the length of time it will wait between samples when bottle 1 is positioned beneath the sampling chamber:

SMPL. INTERVAL Use ↓ to select >Time/Bottle HOME BACK SEL	F3 or Enter	BOT. MIN. #1 (1-9999) >30_ HOME BACK SEL
--	-------------------	---

To change that interval, type the new duration by pressing the corresponding numeric keys. Press the SEL[F3] or Enter key to save that value (changed or not) and display the next:

2 0	BOT. MIN. #1 (1-9999) >20_ UNDO BACK SEL	F3 or Enter	BOT. MIN. #2 (0-9999)0-end >60_ HOME BACK SEL
-----	---	-------------------	--

The digit keys can then be used to change the number of minutes the program would wait between samples for the second bottle. Pressing the SEL [F3] or Enter key would again save the displayed value and display the next. And so on until pressing the SEL [F3] or Enter key while Bottle Minutes #24 is displayed restores the Program Configuration menu scrolled to its next group (Bottle Options).

6 0	BOT. MIN. #24 (0-9999)0-end >60_ UNDO BACK SEL	F3 or Enter	PGM CONFIG Use ↓ to select > Bottle Opts. HOME BACK SEL
-----	---	-------------------	--

However, you do not need to set all 24 intervals—setting any one of them to 0 configures the program to use the value of the preceding parameter for all subsequent intervals. For example, setting Bottle Minutes #5 to 120 and Bottle Minutes #6 to 0 would have the same effect as setting Bottle Minutes #6 through #24 all to 120 (the value of Bottle Minutes #5):

1 2 0	BOT. MIN. #5 (0-9999)0-end >120_ UNDO BACK SEL	F3 or Enter	BOT. MIN. #6 (0-9999)0-end >150_ HOME BACK SEL
0	BOT. MIN. #6 (0-9999)0-end >0_ UNDO BACK SEL	F3 or Enter	PGM CONFIG Use ↓ to select > Bottle Opts. HOME BACK SEL

4.4.5: Per-Bottle Flow Interval Sampling

Selecting the **Flow/Bottle** sampling interval option configures the program to draw samples at flow intervals that are tied to the position of the bottle carousel.

Before specifying those intervals, you must first select the flow input type. For instructions on doing that, please refer to the Flow Interval Sampling (Chapter 4.4.2). Once you have done that, the screens you will see depend on whether you are using an analog or a discrete input:

- For analog flow inputs, you first specify the flow rate corresponding to the transmitter’s maximum signal and then specify the sampling intervals in gallons. The procedures are the same as described previously in the Analog Flow Input (Chapter 4.4.2.1.1) and the Variable Flow Intervals (Chapter 4.4.2.1.2).
- The flow interval for samples deposited to the first bottle are specified by the Sample Gallons #1 parameter, the interval for the second bottle’s samples are specified by the Sample Gallons #2 parameter, and so on.
- For discrete flow signals, those intervals are specified as pulse counts. The procedure is the same as described previously in the Variable Pulses Flow Intervals (Chapter 4.4.2.2.2).

The flow interval for samples deposited to the first bottle are specified by the Sample Pulses #1 parameter, the interval for the second bottle’s samples are specified by the Sample Pulses #2 parameter, and so on.

4.5: Bottle Options

This group includes one main parameter that specifies which type of sample containers your sampler has (Chapter 1.3.2), and a set of parameters for each possible type. To directly access that main parameter, select the program you want to configure (Chapter 4), then press the Down key twice to scroll to the Bottle Options group:



Press the SEL [F3] or Enter key to display the currently selected storage type, then use the Down or Up key to toggle between that parameter’s two possible values. Pressing the SEL [F3] or Enter key will display the first parameter for that sample storage option:

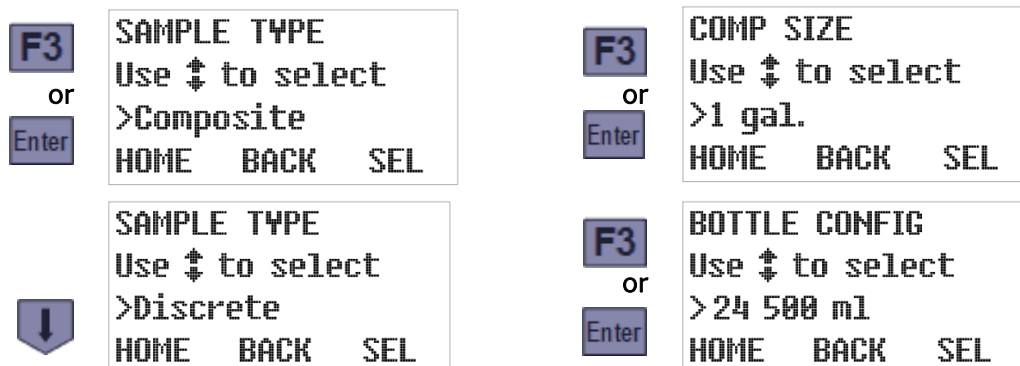

4.5.1: Composite Sample Containers

Selecting the **Composite** bottle option configures the controller to discharge all samples into a single container, and (as shown above) displays the currently configured container size. That size is in either liters or gallons, depending on the current Administration Menu Set Units setting (Chapter 3.2.7).

Use the Up or Down key to scroll to the container size you are using, then press the SEL [F3] or Enter key to save that setting and display the number of samples that container is currently set to receive (note that the maximum is calculated by dividing 90 percent of the container volume by the previously set sample size):

<p>F3 or Enter</p>	<p>COMP SIZE Use \updownarrow to select >1 gal. HOME BACK SEL</p>	<p>F3 or Enter</p>	<p>SMPLS/BOTTLE (1-34) >34_ HOME BACK SEL</p>
<p>↓</p>	<p>COMP SIZE Use \updownarrow to select >2.5 gal. HOME BACK SEL</p>	<p>F3 or Enter</p>	<p>SMPLS/BOTTLE (1-85) >85_ HOME BACK SEL</p>
<p>↓</p>	<p>COMP SIZE Use \updownarrow to select >3 gal. HOME BACK SEL</p>	<p>F3 or Enter</p>	<p>SMPLS/BOTTLE (1-102) >102_ HOME BACK SEL</p>
<p>↓</p>	<p>COMP SIZE Use \updownarrow to select >5 gal. HOME BACK SEL</p>	<p>F3 or Enter</p>	<p>SMPLS/BOTTLE (1-170) >170_ HOME BACK SEL</p>

Each unit is generally factory set to display only the bottle sizes its owner purchased, so the options you see will probably differ from those shown above.

The digit keys can then be used to change the number of samples the program will discharge to the container before automatically stopping itself. Pressing the SEL [F3] or Enter key will save the displayed value and display the Program Configuration menu with its next group selected:

<p>7 5</p>	<p>SMPLS/BOTTLE (1-85) >75_ UNDO BACK SEL</p>	<p>F3 or Enter</p>	<p>PGM CONFIG Use \updownarrow to select > Pgm. Run Opts. HOME BACK SEL</p>
--------------------------	--	--	---

This setting might be automatically reduced if you subsequently select a smaller container or increase the configured sample size.

4.5.2: Discrete/Sequential Sample Containers

Selecting the **Discrete** bottle option configures the controller to discharge samples into multiple bottles mounted in a rotating carousel, and (as previously shown) displays the currently selected bottle configuration. Use the Up or Down key to scroll to the configuration you are using, then press the SEL [F3] or Enter key to save that setting and display how many of those bottles the program is currently configured to use:

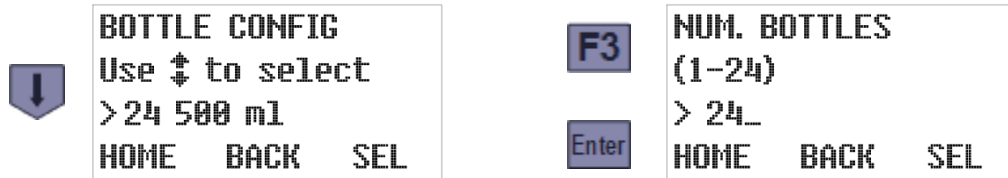

The numeric keys can then be used to change that number, and pressing the SEL [F3] or Enter key will save the displayed value (changed or not) and display the maximum number of samples the program is currently set to discharge to each bottle:



The numeric keys can then be used to change that number, and pressing the SEL [F3] or Enter key will again save the displayed value and display the currently bottle indexing setting:















4.5.2.1: Bottle Indexing Options

The controller can be configured to rotate the next bottle under the sample chamber using any one of the following indexing criteria:

- The **After Bottle** option rotates the turntable after the specified number of samples have been discharged to the current bottle. For example, if each bottle is to get 3 samples, the carousel will be turned after the third sample, the sixth, the ninth, and so on until the previously specified number of bottles have each received 3 samples.
- The **After Sample** option rotates the turntable after each sample, and continues doing so until the specified number of samples have been discharged to each bottle. For example, if each bottle is to receive 3 samples, the carousel will make three full revolutions.
- The **After Time** option rotates the turntable each time a specified indexing interval elapses. For example, the carousel might be turned every 3 hours until the previously-specified number of bottles have be serviced. This option is usually combined with Flow Interval sampling to provide flow-proportional sampling.
- The **Real Time** option rotates the turntable at fixed-duration intervals starting at a specified time of day (today if the program is started before that time, otherwise tomorrow).

Use the Up or Down key to scroll to the indexing type you wish to use, then press the SEL [F3] or Enter key to save that choice and display its first associated parameter (if any) or return to the Program Configuration menu with its next group selected:

	<pre>INDEX TYPE Use ↑↓ to select >After Bottle HOME BACK SEL</pre>	 	<pre>PGM CONFIG Use ↑↓ to select >Pgm. Run Opts. HOME BACK SEL</pre>
	<pre>INDEX TYPE Use ↑↓ to select >After Sample HOME BACK SEL</pre>	 	<pre>PGM CONFIG Use ↑↓ to select >Pgm. Run Opts. HOME BACK SEL</pre>
	<pre>INDEX TYPE Use ↑↓ to select >After Time HOME BACK SEL</pre>	 	<pre>INDEX MIN. (1-9999) > 60_ HOME BACK SEL</pre>
	<pre>INDEX TYPE Use ↑↓ to select >Real Time HOME BACK SEL</pre>	 	<pre>INDEX TIME hh:mm:ss ↑↓⊞ 12:34:56 ESC ◀▶</pre>

4.5.2.2: After Time Indexing

As shown above, selecting the **After Time** indexing type displays the number of minutes each bottle will be positioned under the sampling chamber. You can then use the numeric keys to change that setting, and pressing the SEL [F3] or Enter key will again save the displayed value (changed or not) and display the Program Configuration menu with its next group selected:

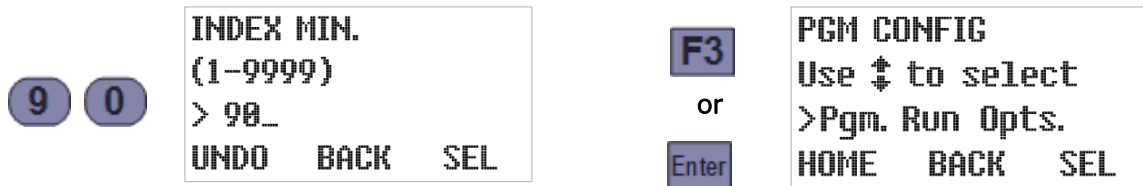

4.5.2.3: Real Time Indexing

As shown on the previous page, selecting **Real Time** indexing displays the time of day at which timed-indexing of the bottle carousel is to begin (Appendix A.3.3.2.4):

- Press the Previous [F2] or Next [F3] key to move the underline cursor (which initially selects the first digit of the hour for editing) one digit left or right.
- Press the appropriate numeric key to set the selected digit and automatically move the cursor to the right, OR
Press the Up or Down key to increment or decrement that digit, then press the Previous [F2] or Next[F3] key to manually move the cursor.
- Press the ESC[F1] key to cancel any changes and redisplay the Index Type screen.

Pressing the Enter key will then save the displayed time and display the number of minutes each bottle will be positioned under the sampling chamber from that time forward:

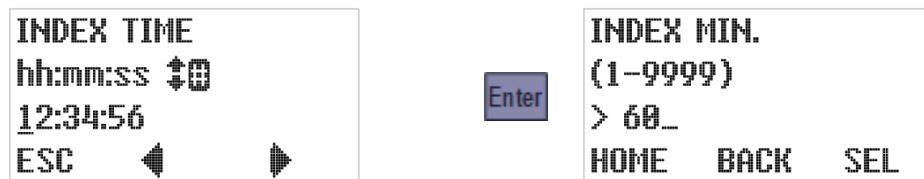

You can then use the numeric keys to change that indexing interval, and press the SEL [F3] or Enter key to save its displayed value (changed or not) and display the Program Configuration menu with its next group selected:



4.5.3: Installing Sequential Drive Table:

1. When installing the sequential drive table position the table with the wires toward the back and the two mounting holes on the left and right sides.
2. Fasten the drive table down with the two screws that were provided with the table.
3. Connect the black table connector to the connection located inside the refrigerator.
4. Install the bottle tub.

5. Go to the program menu and enter in the Bottle Opt. Menu. Select the bottle configuration that you have. Then exit the menu to the program Run screen. The table will advance to bottle one. After the turntable has stopped, the discharge tube should be in the center of bottle one.

Note

Do not try to manually rotate the sequential table. This may damage the drive system.



Figure 4-1: Sequential Turntable

4.5.4: Remove Sequential Sample Bottles

After the program is complete the bottles can be removed and prepared for the laboratory.

1. Gain access to the bottles by releasing the door latch and swinging the door open.
2. The bottles can then be removed from the table by lifting the sequential tub up and remove

4.6: Program Run Options

This group includes the parameters that configure the following features:

- automatic rerun (Chapter 4.6.1)
- delayed starting (Chapter 4.6.2)
- float enable (Chapter 4.6.4)
- fault enable (Chapter 4.6.3)
- timed stop (Chapter 4.6.5)
- bottle limit override (Chapter 4.6.6)

To directly access those parameters, select the program you want to configure (Chapter 4):

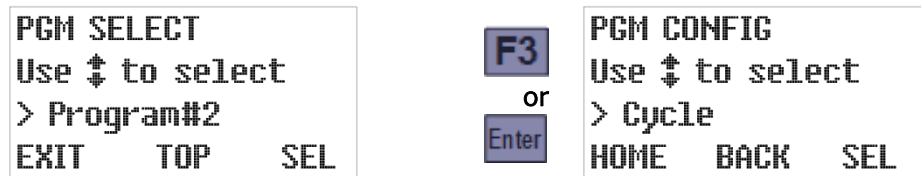

Press the Up key twice to scroll to the Program Configuration menu's Run Options group, then press the SEL [F3] or Enter key again to display that group's first setting:



4.6.1: Automatic Rerun

By default, the sampling program must be manually reset each time it stops, which indicates to the controller that the sample containers have been emptied. If you configure a Start Event (Chapter 4.6.1) to repeatedly start and stop the sampler, enabling the Automatic Rerun parameter as well would enable the program to restart without being reset.

⚠ You should not enable this parameter unless you are scheduling automatic start events.

To view and optionally change this setting:

1. Select the Run Options group to display this parameter's current value (see above).
2. If desired, press the Up or Down key to toggle it on or off, then press the SEL [F3] or Enter key to save the displayed value (changed or not) and advance to the next Run Options group parameter.

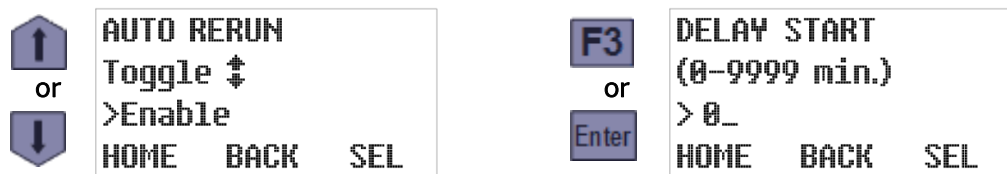

4.6.2: Delayed Start

By default, starting a sampling program will immediately initiate its interval timers. If it is set up to draw samples at one-hour intervals, for example, the first will be taken one hour after the program is started. You can configure it to wait longer than that by setting a non-zero start delay. Other methods of delaying the first sample are to use the Float Enable parameter (Chapter 4.6.4), schedule regular automatic Start Events (Chapter 5.3.3), or manually set up one-time Timed Starts (Chapter 5.3.1).

To view and optionally change this setting:

1. Accept or change the Auto Rerun setting, which will display this parameter's current value.
2. If desired, type the new delay duration by pressing the corresponding numeric keys. When you type the first digit, the old value is erased and the F1 prompt changes from HOME to UNDO. You can then press the UNDO [F1] key to start over, or the BACK [F2] or Back key to delete the most-recently typed digit.
3. Press the SEL [F3] or Enter key to save the displayed value (changed or not) and advance to the next Run Option group parameter.

Example: To change the start delay to 360 minutes:



4.6.3: Fault/Alarm Option

This parameter specifies whether the alarm relay (Appendix A.2.2) should energize when the sampling program is waiting to be reset (whether it completed normally, was manually stopped, or detected a fatal fault) or is continuing to run despite have detected a non-fatal fault.

To view and optionally change this setting:

1. Accept or change the Delay Start setting to display this parameter's current value.
2. If desired, press the Up or Down key to toggle it on or off, then press the SEL [F3] or Enter key to save the displayed value (changed or not) and advance to the next Run Options group parameter.

The alarm output is based one of the following events: 

- **Program Done:** This event occurs when a running program has finished or the sample bottle has reached the maximum number of samples. This alarm output stays on as long as the run time display reads **PGM : DONE**.
- **Recycle:** The collection of incomplete samples by repeating the sampling cycle as many as four times. To enable or disable it:
- **Temperature Error:** The temperature has been above its set temperature for more than 30 minutes.
- **Failed Sample:** This event occurs when the sample does touch the liquid-sensor electrodes.
- **Indexing Error:** This event occurs when the sampler has an indexing failure. This condition needs corrected before the sampling program can resume. This alarm output stays on until the condition is corrected.
- **Rinse Error:** This event occurs when the vacuum time is set to long and sample enters the sample chamber during the vacuum time in the Rinse menu.

4.6.4: Float Option

Depending if the FLOAT INPUT options have been **factory-configured**, enabling this input will configure the sampling program to delay sample collection until that circuit closes and subsequently either: **This feature is configured at the factory.**

- **Float Start:** If the FLOAT START setting is selected, the program will start with a closed contact and the program will continue sampling without interruption even if that circuit re-opens.
- **Float Start/Stop:** If the FLOAT START/STOP setting is selected, the program will reset its sampling interval counters and not restart them until the float circuit closes again (i.e., those counters will restart from zero when the water level rises high enough to close the float switch). This feature is used for the full bottle shut off switch.

1. Accept or change the Fault Option setting, which will display this parameter's current value.
2. If desired, press the Up or Down key to toggle it on or off, then press the SEL[F3] or Enter key to save the displayed value (changed or not) and advance to the next Run Options group parameter.

4.6.5: Timed Stop

This parameter configures the program to automatically stop a specified number of hours or minutes after it initiates its interval timers. To view and optionally change its value:

1. Accept or change the Float Option setting, which will display this parameter's current value.
2. If desired, press the Up or Down key to scroll to the desired value, then press the SEL[F3] or Enter key to save that value (changed or not). Selecting any option other than Custom will save that value and display the next Run Option parameter's current value:

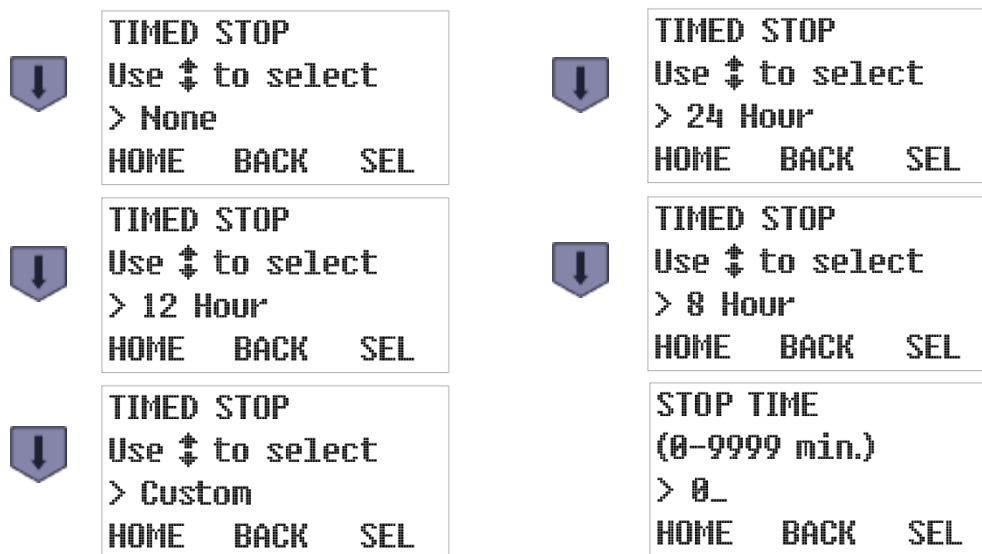

Selecting the Custom option displays a screen for setting the number of minutes the program will run before automatically stopping. The digit keys can then be used to change that setting, and pressing the SEL [F3] or Enter key will save the displayed value and display the next Run Option parameter's current value:



4.6.6: Bottle Limit Override

Each program's Bottle Options (Chapter 4.5) configure it to stop after discharging a specific number of samples into its composite sample container (or each of its discrete sample bottles), provided this parameter has its default "Program Stop" value. If you would prefer that the unit continue drawing samples indefinitely, without keeping track of how full the sample container is (or bottles are), you should instead set this parameter to "Program Continue":

1. Accept or change the Stop Time setting, which will display this parameter's current value.
2. If desired, press the Up or Down key to toggle between its two possible values, then press the SEL [F3] or Enter key to save the displayed value (changed or not) and return to the Program Configuration menu.



4.7: Program Events

Each program's scheduled events (Appendix A3.6) are defined by a list that can be accessed via the **Program Events** group. Each event on that list has three associated values:

- the type of event (start, stop, pause, halt, resume or manually sample),
- the days of the week on which the event will be executed, and
- the time of day on those days at which the event will be initiated.

Events are consecutively numbered as they are defined, so the event numbers shown when you review the list do not indicate the order in which those events will be executed. You cannot directly access a particular event's settings, add a new event without reviewing those already on the list, or delete an event without deleting all higher numbered events as well. But you can disable an existing event (by setting it to execute on no days of the week), or replace it by changing any or all of its three settings (type, days and/or time).

4.7.1: Reviewing Scheduled Events

When you access the Program Events group, it will initially display the event type for the first event on the list (which will be **End List** if there are none). Repeatedly pressing the Enter key will then display the remaining settings for that event, followed by the settings for the second event, and so on until you reach the first undefined event (whose type will be **End List**).

To review the event schedule:

1. Select the program you want to schedule events for:

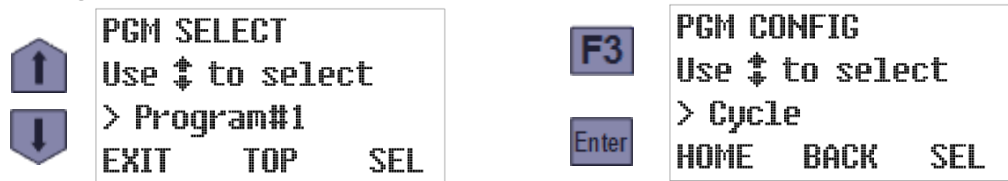

2. Press the Up key to scroll to the Program Events group, then press SEL[F3] or the Enter key to display the type of the first scheduled event (**Start Time** in the example below):

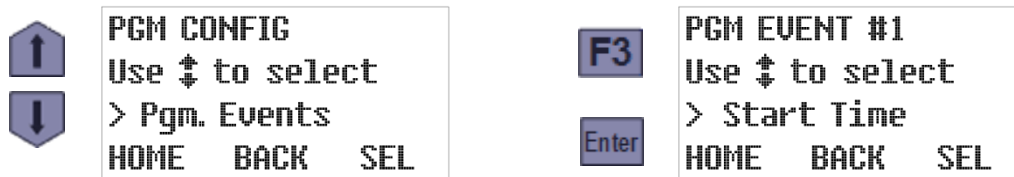

3. Press the Enter key to view that event's days setting, and again to view its time setting:



The second line of the WEEKDAYS screen displays seven letters representing the days of the week, while the third displays bullets indicating the days (if any) on which the event will occur—Monday through Friday in the example to the left above.

Similarly, the second line of the EVENT TIME screen displays the program's 24-hour time (a.k.a. military) time format while its third line indicates the time on those days at which this event will be initiated—2:00 PM (1400 hours) in the example to the right above.

4. Continue pressing the Enter key repeatedly to review each event in turn. You can also re-examine previously-viewed screens by repeatedly pressing the Back key.
5. After you have reviewed the last listed event, the readout will indicate you have reached an event assigned the End List type. You can then press the Event key again to return to the Program Configuration menu or add a new event to the end of the list (see below).



4.7.2: Adding and Editing Events

Entirely new events can only be added to the end of the list, by changing the placeholder **End List** event that is displayed after you review the last existing event (see above). However, you might be able to effectively add a new one by editing a disabled event (Chapter 4.7.4). *In either case, there is no procedural difference between adding and editing an event.*

1. Navigate to the **Program Events** group and access its End List event as described above:

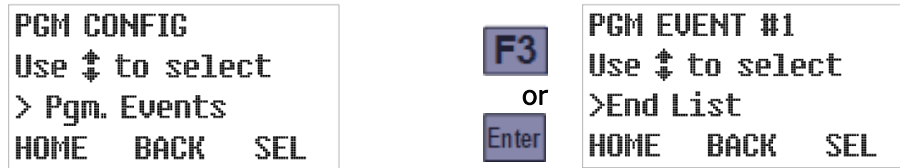

⚠ This example assumes no events have yet been set up. If any have, you must review them (see above) in order to access the End List event. While doing so, you can verify that the event has not been set up previously and make sure it would not be better to create it by rescheduling or otherwise editing an existing event.

2. Use the Up or Down key to scroll to the desired event type (Start Time, for example), then press SEL [F3] or the Enter key to save that selection and display the Weekdays screen:

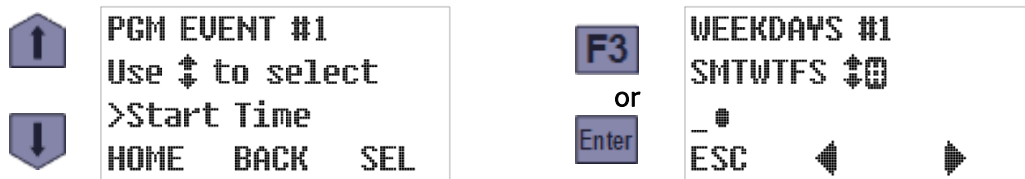

3. The third line includes an underline cursor that can be moved to a different day by pressing the Previous [F2] or Next [F3] key:

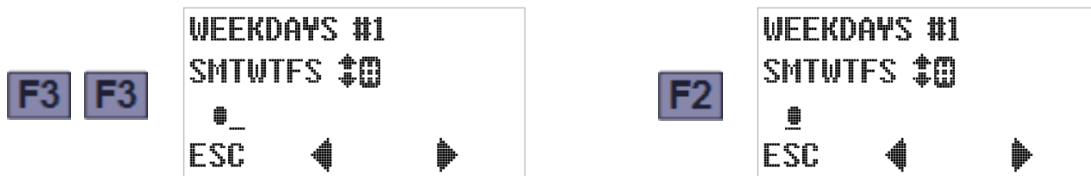

4. Pressing the Up or Down key will toggle execution on the cursor-selected weekday on or off, as indicated by the arrows prompt at the end of the second line:



- You can schedule an event to occur on a specific set of days by pressing the 7 (all days), 0 (no days), 2 (Saturday and Sunday only), or 5 (Monday through Friday) key—as hinted by the hash tag/number sign prompt at the end of the second line:

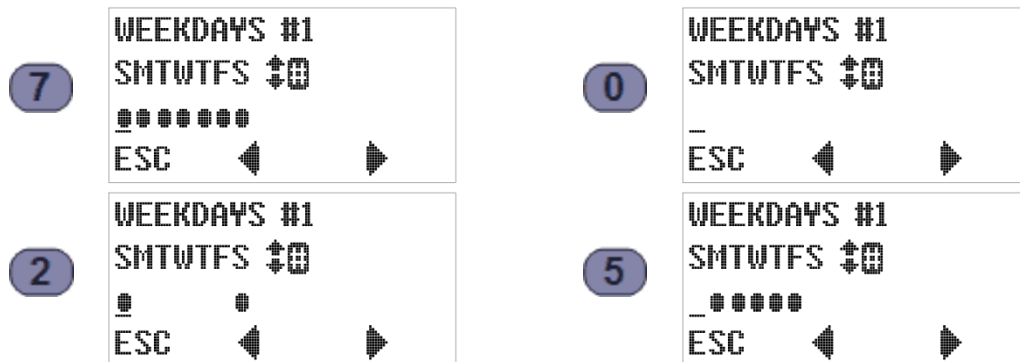

- Pressing the ESC [F1] key cancels any change(s) you have tentatively made to this setting (but not any changes made to the current event's other settings) and restores the parent Program Event screen. For example:



- Pressing the Enter key saves the weekdays setting and displays the Event Time screen:

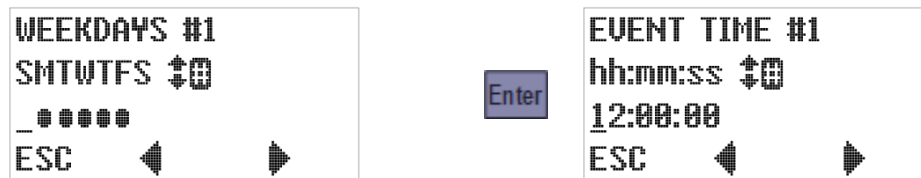

Again, an underline cursor indicates the digit currently subject to editing:

- Press the Previous [F2] or Next [F3] key to move that cursor one digit left or right.
 - Press any appropriate numeric key to set the current digit and advance the cursor OR press the Up or Down key to increment or decrement the current digit (either action is recognized only if a valid time results).
 - Press the ESC [F1] key to undo any change to the displayed time and return to the Weekdays screen.
- Pressing the Enter key saves the indicated time setting and displays the first screen for the next Program.

4.7.3: Deleting Events

Events can be deleted only from the end of the list—by reviewing the settings for each event you want to keep and then changing the type of the first one you want to delete to **End List**.

⚡ *An event could effectively be removed from the middle of the list by disabling it, as described in the next topic.*

For example, if there were eight listed events and you wanted to delete all but the first two:

1. Access the **Program Events** group as described above:

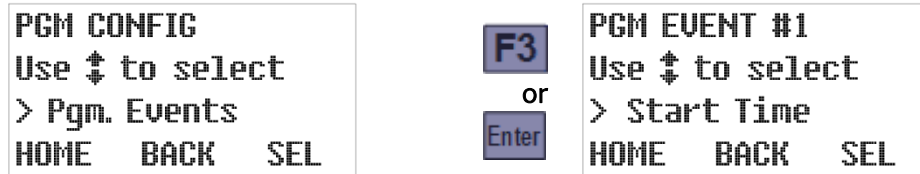

2. Press the Enter key repeatedly until the first Event #3 screen appears, then use the Up or Down key to scroll to the End List event type:



3. Finally, press SEL [F3] or the Enter key to delete this and any higher-numbered events:

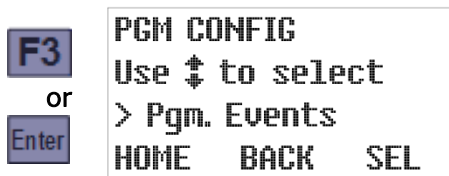

4.7.4: Disabling Events

You can disable an event without deleting it (so you could later re-enable it), or effectively delete an event from the middle of the list, by configuring it to occur on no days of the week. For example, if there are four or more defined events but you no longer want the third one to execute:

1. Access the **Program Events** group as previously described:

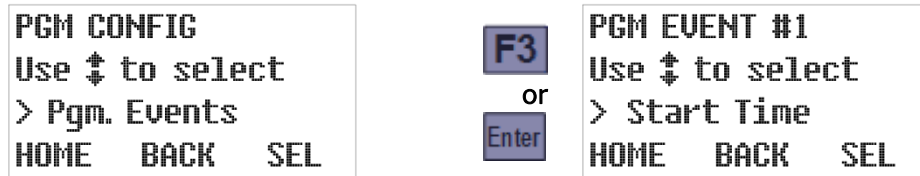

2. Press the Enter key repeatedly until the first Event #3 screen appears. The displayed event type will be irrelevant once the event has been disabled, so you need only press SEL [F3] or the Enter key to display its WEEKDAYS screen:



3. Press the 0 (zero) key to deselect all days of the week, then press the Enter key to save that change and display the event's execution time:



4. The time setting will also be irrelevant given that execution has been disabled for every weekday. So you need only press the Enter key to display the next event's type screen, from which you can exit the Program Events group by pressing HOME[F1]:

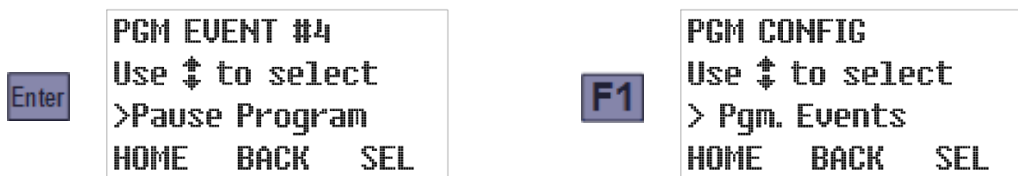

Chapter 5: Sampler Operation

Although your Refrigerated Samplers sampler requires little or no operator intervention, its user interface panel can be used to:

- select a different sampling program (Chapter 4.1)
- start the indicated program (Chapter 5.3)
- monitor the program while it is running (Chapter 5.4)
- manually collect unscheduled samples (Chapter 5.4.3.2)
- pause and resume sample collection (Chapter 5.5)
- stop and reset the sampling program (Chapter 5.6)
- review archived sample collection data (Chapter 5.7)

That interface (see below) is mounted in the upper shell's top panel and consists of a keypad and a four-line LCD readout:

- The readout's top line identifies the selected program and displays its operating state.
- Its second and third lines display sets of status information you can cycle through by pressing the Up or Down keys to the right of the readout.
- Its bottom line indicates the functions of the F1, F2 and F3 keys.

In addition, any of the icons listed in Table 5-1 might be displayed along its right edge.

Figure 5-1: User Interface Panel and Icons

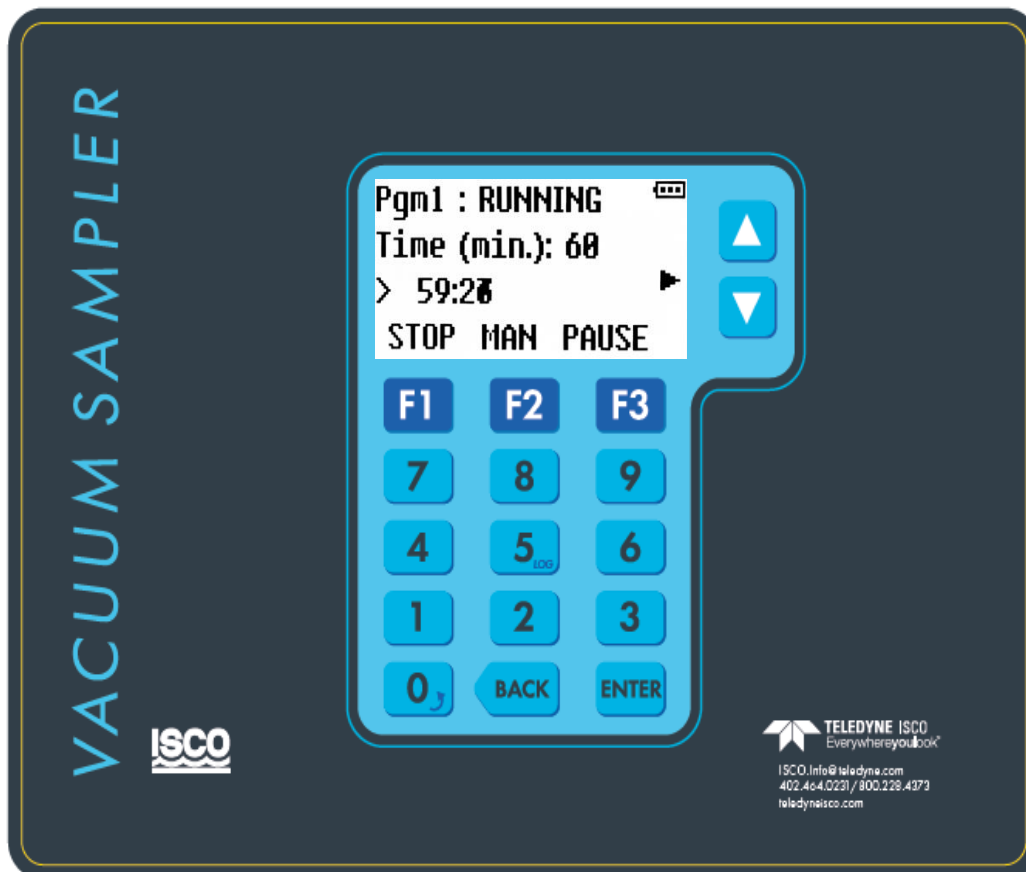









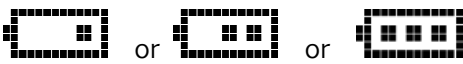

Table 5-1: User Interface Panel and Icons

	Program is Running.
	Program is Paused.
	Program will automatically start at a specified time.
	Program will automatically stop at a specified time.
	Sequential turntable is rotating.
	Recycle activated/sampling cycle is repeated.
	Alarm condition has been met.
	Temperature Alarm, displayed when temperature out of range for 30 minutes.
	Arrow up: float circuit is closed.
	Arrow down: float circuit open.
	Power supply voltage level. This will always be full for AC powered units.

5.1: Ready State

The LCD's top line identifies the selected program and its operating state, which is "READY" while it is waiting to be started. The second and third lines display sets of additional information you can scroll through using the Up and Down keys:

If set for Time+Flow intervals, the elapsed Time and Gallons or Time and Pulses will be shown. If not, only one of them will.

```
Pgm1 : READY
Time (min.): 60
> 60:00
RUN TIMED MENU
```

Program 1 is set to sample at timed intervals. The first one will be drawn 60 minutes after the program is started.

```
Pgm1 : READY
Gallons : 2500
> 0 : 0%
RUN TIMED MENU
```

Program 1 is set to sample at flow meter volume intervals. The first one will be drawn 2500 gallons after the program is started.

```
Pgm1 : READY
Pulses : 600
> 0 : 0%
RUN TIMED MENU
```

Program 1 is set to sample at flow meter pulse intervals. The first one will be drawn 600 pulses after the program is started.



```
Pgm1 : READY
Smp1:#1
12:34:56 07/08/15
RUN TIMED MENU
```

The next sample drawn will be the first. The current time is 12:34:56. The current date is July 8, 2015.



```
Pgm1 : READY
Comp: 5 gal.
Smp1#: 0 of 168
RUN TIMED MENU
```

Program 1 is set to discharge 168 samples into a 5 gallon container.

OR



```
Pgm1 : READY
Bot1#1: 24 500
Smp1#: 0 of 4
RUN TIMED MENU
```

Program 1 is set to discharge 4 samples into each of up to 24 500 milliliter bottles

```
Pgm1 : READY
Temp.: 4.2 °C
Power: 15.6 V
RUN TIMED MENU
```

The current sample storage compartment temperature is 4.2 degrees Celsius and the control system power supply or connected battery is providing 15.6 VDC power.

When the program is waiting to be started:

- Pressing the RUN[F1] button starts it immediately.
- Pressing the TIMED [F2] button allows you to set the date and time at which it will start.
- Pressing the MENU [F3] key will activate the menu system, from which you could select a different program (Chapter 4.1).

5.2: Sampler Conditions

The approximate control system power supply voltage is always indicated by a battery icon in the upper right corner of the user interface readout, and you can scroll to a screen that displays that voltage and the current sample storage compartment temperature:

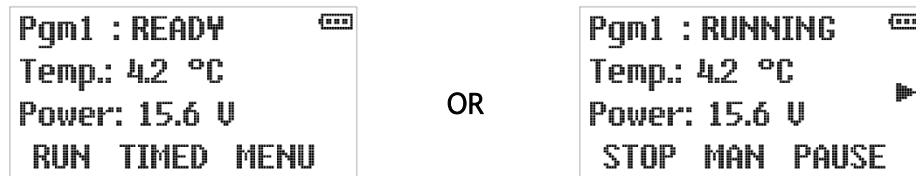

A fault icon will also be displayed if any of the following fault condition exists: 

- sampling has been suspended because the float input circuit is open;
- the most recent sample cycle failed to collect the programmed size sample; or
- the storage compartment has been above its intended temperature for at least 30 minutes (this will also be indicated by displaying a °C icon). 

Those conditions will also energize the Alarm Relay (if enabled), which is also energized when the program is waiting to be reset after completing normally, being manually stopped, or failing to determine the position of the sequential-sampling turntable.

5.3: Starting the Selected Program

When the control system is in its Ready state:

- Pressing the RUN [F1] key starts the selected sampling program immediately. The first sample will be taken once the turntable reaches home position or a programmed delay has timed out. However, it might not begin sampling until a time delay elapses, a stream-level float switch closes, or a scheduled time arrives.
- Pressing the TIMED [F2] key allows you to set a timer that starts that program at a specified time and date (see Timed-Delay Starting below). Any configured time or float-input delay would further delay the first sampling interval.
- Pressing the MENU [F3] key will activate the menu system (Chapter 3.1). You could then select a different program using the Program Menu (Chapter 4), although you might first need to enter the administration password (Chapter 3.2.2).

5.3.1: Timed-Delay Starting

The interval counter(s) will not start until the start delay (if non-zero) has elapsed. In the meantime, the operating state will display as DELAYED and the first information screen will indicate the progress of that delay:

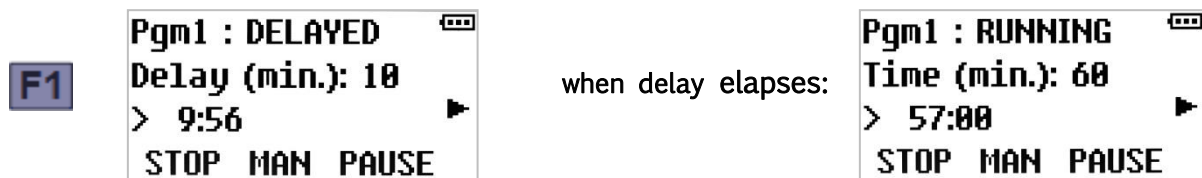

5.3.2: Float-Delayed Starting

If the float input is enabled (Chapter 4.6.4), the sampling program will not start its interval counter(s) until the float-switch circuit is closed (Appendix A.2.6). Those counter(s) will remain at zero as long as the float icon points down and start accumulating when it points up (think of this icon as a thumbs-up or thumbs-down indicator):

```
Pgm1 : FLT START
Time (min.): 60
> 60:00
STOP MAN PAUSE
```

Closed Contact

```
Pgm1 : RUNNING
Time (min.): 60
> 59:20
STOP MAN PAUSE
```

Open Contact

Depending on which of the Factory Menu float input options is enabled, the sampler will either continue or suspend sampling (Chapter 5.5.1) when the float-switch circuit reopens.

5.3.3: Timed Starting

The selected program can also be started by pressing the TIMED [F2] key, which displays the first of two screens from which you specify the date and time at which you want it to start:

```
Pgm1 : READY
Time (min.): 60
> 60:00
RUN TIMED MENU
```

F2

```
START TIME
mm/dd/yy
01/23/15
ESC
```

That screen initially displays today's date. Leave it unchanged or:

- Press the Previous [F2] or Next [F3] key to move the underline cursor (which initially selects the first digit of the month for editing) one digit left or right.
- Press the appropriate numeric key to set the selected digit and automatically move the cursor to the right, OR
Press the Up or Down key to increment or decrement that digit, then press the Previous [F2] or Next [F3] key to manually move the cursor.
- Press the ESC [F1] key to cancel the Timed Start and return to the Ready state screen.

Once the desired start date has been set, press the Enter key to save it and display the screen for specifying the time of day at which the program should start. That screen initially shows the current time, which can be changed using the same methods as the date. Use F2 and F3 to select a digit you want to change, then press the Up or Down arrow or a numeric key to change that digit as desired. Finally, press Enter to initiate the TIMED operating state discussed in the following section:

```
START TIME
hh:mm:ss
14:00:00
ESC
```

Enter

```
Pgm1 : TIMED
14:00:00 01/23/15
15:32:46 01/21/15
STOP MAN PAUSE
```

5.3.3.1: Timed State

The Timed operating state is entered when the selected program is:

- set to start at a specified time and day (see previous section), or
- configured to start (or restart) at scheduled times on specified days of every week and then manually started by pressing the RUN [F1] key (see next section).

The run-time screens will then display a clock icon and you can scroll to an additional screen that shows the time and date at which the interval counters will start. The following example of that screen indicates sampling will begin in approximately two days:

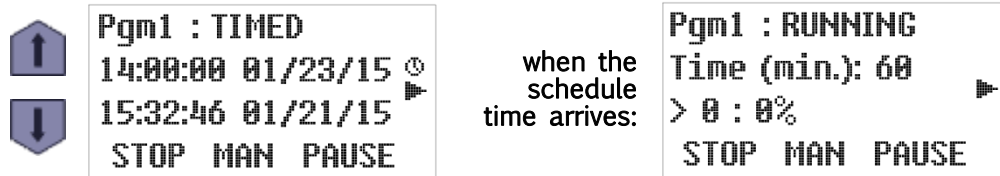

When that time arrives, the program proceeds as if you had just pressed the RUN [F1] key:

5.3.4: Scheduled Starting

Each program can be configured to start (or restart) at scheduled times on specified days of every week. Manually starting such a program will initiate its Timed operating state (see above). When the scheduled start time arrives, the program will proceed as if you had just pressed the RUN [F1] key.

When that program completes or is stopped, it will have to be reset before the next start event can restart it unless it is also configured for automatic restarting. If it is, it will instead reset itself and then enter its Auto Rerun state, which is identical to the Timed state described above except the displayed state would be AUTO RERUN instead of TIMED:



When this screen first appears, the sample containers should be replaced with empty ones.

5.4: Running State

Once the selected program has initiated its sampling-interval counters, the readout's top line displays its operating state as "RUNNING". The second and third lines display scrolling sets of additional information similar to those available in the Ready state:

If set for Time+Flow intervals, the elapsed Time and Gallons or Time and Pulses will be shown. If not, only one of them will.



```
Pgm1 : RUNNING
Time (min.): 60
> 57:00
STOP MAN PAUSE
```

Program 1 is sampling at timed intervals. The next one will be drawn after a 60 minute interval and the time interval counts down.

```
Pgm1 : RUNNING
Gallons : 2500
> 1048 : 42%
STOP MAN PAUSE
```

Program 1 is sampling at measured flow intervals. The next one will be drawn after a 2500 gallon interval that started 1048 gallons ago (42 percent elapsed).

```
Pgm1 : RUNNING
Pulses : 600
> 253 : 42%
STOP MAN PAUSE
```

Program 1 is sampling at flow meter pulse intervals. The next one will be drawn after a 600 pulse interval that started 253 pulses ago (42 percent elapsed).



```
Pgm1 : RUNNING
Smp1:#8 : 100 ml
12:34:56 07/08/15
STOP MAN PAUSE
```

Program 1 is drawing 100 ml. samples. The next one will be the eighth (#8). The current time is 12:34:56. The current date is July 8, 2015.

sample container screens (Chapter 5.4.2)

start timer (Chapter 5.3) or stop timer (Chapter 5.6) screen



```
Pgm1 : RUNNING
Temp.: 4.2 °C
Power: 15.6 V
STOP MAN PAUSE
```

The current sample storage compartment temperature is 4.2 degrees Celsius and the control system power supply or connected battery is providing 15.6 VDC power

When the indicated program is running, the top row keys are assigned the following functions:

- Pressing F1 will immediately stop the program (Chapter 5.6).
- Pressing F2 will immediately trigger the collection of a manual sample (Chapter 5.4.3.2).
- Pressing F3 will pause the sampling (Chapter 5.5).

5.4.1: Sampling Intervals

As shown on the previous page, the second and third lines of the primary run-state readout will depend on whether the selected program is configured to draw samples at the end of elapsed time (minutes) or stream flow (gallons or pulses) intervals.

If the program has been configured to sample at the ends of flow intervals with a time limit, both screens will be displayed—you can then use the Up and Down keys to scroll between them. When either interval counter reaches 100 percent, both counters will be reset as an automatic sampling cycle is initiated.

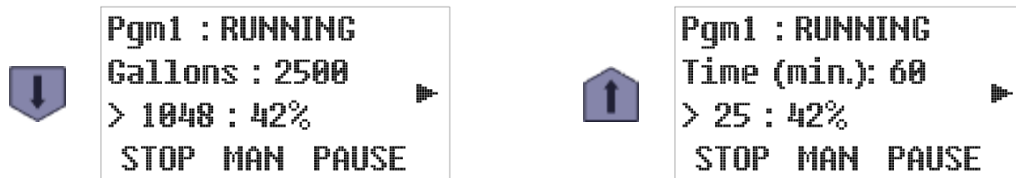

5.4.2: Sample Container Screens

Unless the No Limit option (Chapter 5.6) has been enabled, the controller will keep track of the total volume of wastewater discharged to each sample container and stop if it exceeds 90 percent of the container’s capacity. The following run-state screens indicate which containers are installed and how full they are:

- These screens are for a composite-sampling 5 gallon container:

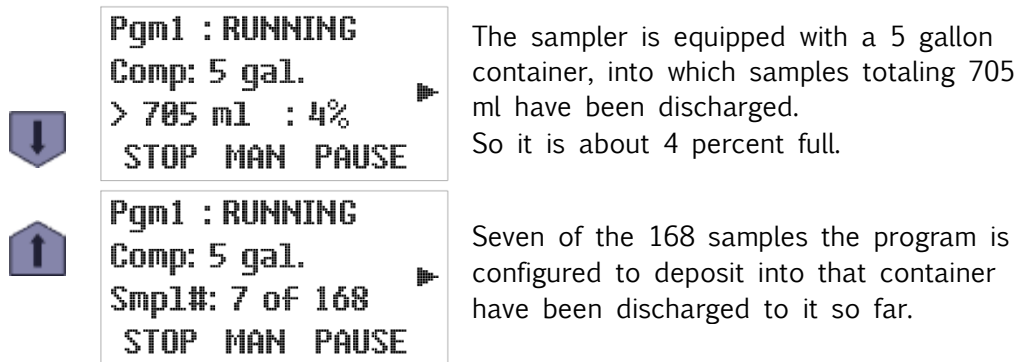

The container size is shown in either liters or gallons, depending on the Administration Menu Set Units setting (Chapter 3.2).

- These screens are for a sequential sampling system with 24 1000 ml bottles:

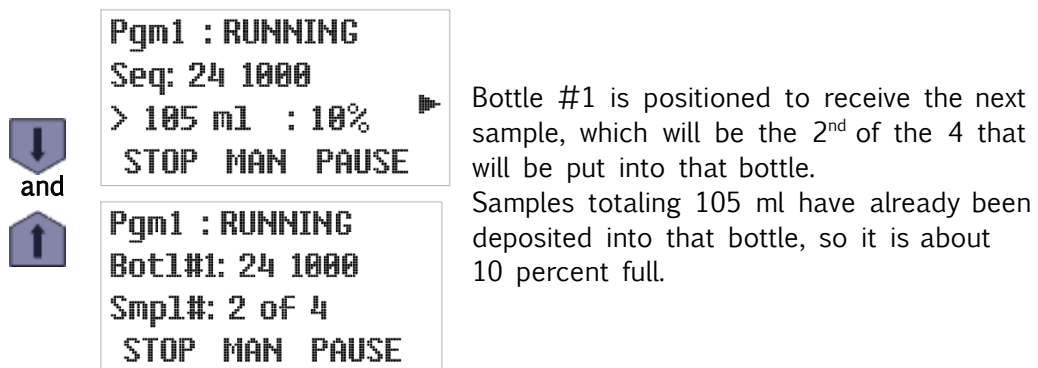

A broken-arrow icon along the right side indicates the carousel is being rotated to the indicated bottle. The program will stop and set its alarm relay if it cannot operate the turntable or determine its position:

<pre>Pgm1 : RUNNING Bot1#2: 24 500 Smp1#: 0 of 4 STOP MAN PAUSE</pre>	if unable to rotate to intended position	<pre>Pgm1 : ERROR Indexing Table Index Error RESET</pre>
---	--	--

If the program is configured to advance the carousel at specified time intervals, you can also scroll to an additional run-time screen displaying the progress of the current interval:

	<pre>Pgm1 : RUNNING Index : 120 min. > 100 : 90% STOP MAN PAUSE</pre>	when the indexing interval elapses	<pre>Pgm1 : RUNNING Index : 120 min. > 0 : 0% STOP MAN PAUSE</pre>
---	--	------------------------------------	---

When replacing the sample container(s) with empties, you would normally stop the program (if it was still running), reset it to zero the accumulated sample volume(s), and then restart it. If the No Limit option is enabled, the controller does not track the accumulated sample volumes, that screen is not displayed, and there is no need to stop and reset the program when changing out the containers—**be sure to empty them before they overflow!**

5.4.3: Sampling Cycle

Figure A-2 illustrates the full QLS sampling cycle, which can be configured to include up to four optional **line rinse** and an optional **line pre-purge**. When the running program triggers that cycle (or a manual sample is initiated), the optional Run-Status output is set, the displayed state will change to “SAMPLING” and the second and third lines of the readout will report the progress of the sampling cycle (which requires no operator participation):

<pre>SAMPLING loadcell init... sec: 2 STOP</pre>	initialization counts down to zero, then	<pre>SAMPLING loadcell zero... sec: 20 STOP</pre>
--	--	---

The zeroing step determines the sampling chamber’s tare weight. It should take less than the allotted 20 seconds, after which the cycle will advance to its rinse or pre-purge phase.

If the sample chamber’s tare weight cannot be determined, the remainder of the current sampling cycle will be skipped and the following screen will be briefly displayed:

<pre>SMPL. ERROR Loadcell Not Zeroed... STOP</pre>	after a few seconds	<pre>Pgm1 : RUNNING Time (min.): 60 > 57:00 STOP MAN PAUSE</pre>
--	---------------------	---

Once the load cell has been zeroed, any accumulated water will be blown from the sampling line and strainer by either the first line rinse or the pre-purge:

- If line rinsing is disabled, the program will simply purge the sampling line before suctioning in the intended sample.
- Otherwise, each enabled rinse first blows the line clear and then partially fills it with wastewater. The sample is drawn after the line is purged to complete the final rinse.

<p>as soon as the tare weight is determined</p>	<pre>SAMPLING rinse press... sec: 14 STOP</pre>	<p>these two screens are displayed only if one or more optional rinse cycles have been set up</p>
<p>followed by</p>	<pre>SAMPLING rinse vac... sec: 10 STOP</pre>	
<p>when the final rinse (if any) is completed</p>	<pre>SAMPLING prepurge... sec: 12 STOP</pre>	<p>prepurge counts down, then sample is drawn</p>
		<pre>SAMPLING size: 100 mL. sec: 99 STOP</pre>

The sample is continuously weighed as it is drawn in. When the target weight is reached, the line is again purged and the sample is reweighed:

<p>as soon as the target weight is reached</p>	<pre>SAMPLING postpurge... sec: 25 STOP</pre>	<p>post-purge counts down</p>	<pre>SAMPLING read weight... sec: 4 STOP</pre>
--	---	-------------------------------	--

After the final weight is recorded, pressure is briefly applied to clear the sampling line. Then the discharge valve is opened to drain the sample to the storage container. The optional Run State output is then cleared and the run state readouts are restored:

<p>the chamber is slightly pressurized</p>	<pre>SAMPLING read done please wait... STOP</pre>	<p>then the discharge valve opens</p>	<pre>SAMPLING discharge... sec: 12 STOP</pre>
--	---	---------------------------------------	---

The final purge will purge the sample chamber of any excess sample.

After the discharge step counts down to zero, the running state readouts are restored (the interval counter was restarted when the sample was initiated).

5.4.3.1: Incomplete Sample Recycling

If a minimum of 60 percent of the intended sample weight is not collected within the allotted 99 seconds, a failed sample error will be indicated:

- If “recycling” is disabled, the error screen is displayed for only a few seconds, after which the line is purged and the incomplete sample is weighed.
- If it is enabled, a recycling icon is displayed while the pre-purge and sampling steps are repeated. When the intended weight is reached, or the fourth recycle fails, the line is purged and the sample is weighed.

if the target weight is not reached	<pre>SAMPLING failed sample please wait... STOP</pre>	If recycling is enabled	<pre>SAMPLING failed sample please wait... STOP</pre>
when sample is completed or aborted	<pre>SAMPLING postpurge... sec: 25 STOP</pre>	post-purge counts down	<pre>SAMPLING read weight... sec: 4 STOP</pre>

5.4.3.2: Manual Sampling

Pressing the MAN [F2] key while the selected program is running will trigger the immediate collection of an unscheduled sample using the configured sampling cycle discussed above:

<pre>Pgm1 : RUNNING Time (min.): 60 > 57:00 STOP MAN PAUSE</pre>	<div style="border: 1px solid black; padding: 2px; display: inline-block;">F2</div>	<pre>SAMPLING loadcell init... sec: 2 STOP</pre>
---	---	--

That sample will then be discharged to the bottle meant for the next automatic sample and counted toward the number of samples the program is configured to put into that bottle. If it fills that bottle, the next one will be rotated into place (sequential-sampling units) or the sampling program will be stopped (composite-sampling units).

If an automatic sample would otherwise have been triggered during the manual cycle, the following screen will be briefly displayed:

```
SMPL. INTERVAL
Sample Blocked
>Wait
ESC
```

Blocked samples ARE NOT DRAWN when the manual sample is completed.

5.5: Paused and Halted States Grab sampling

If you press the PAUSE [F3] key while a program is running, it will immediately enter its PAUSED state. Programs can also be configured to automatically pause and resume at scheduled times.

While the program is paused, a paused icon replaces the run icon. The sampling interval will continue to accumulate, but no samples will be taken until the RUNNING state is restored by pressing the RESUME [F3] key:



Notice: The interval continues to accumulate when the program is paused.

Programs can also be configured to halt and resume at scheduled times. The resulting Halted state is similar to the Paused state, except that any configured flow intervals will not continue to accumulate.

While the program is halted, the running icon is replaced by a halted icon (as shown below). The Running state is often automatically restored at a scheduled time, but in any case can be manually restored by pressing the RESUME [F3] key:

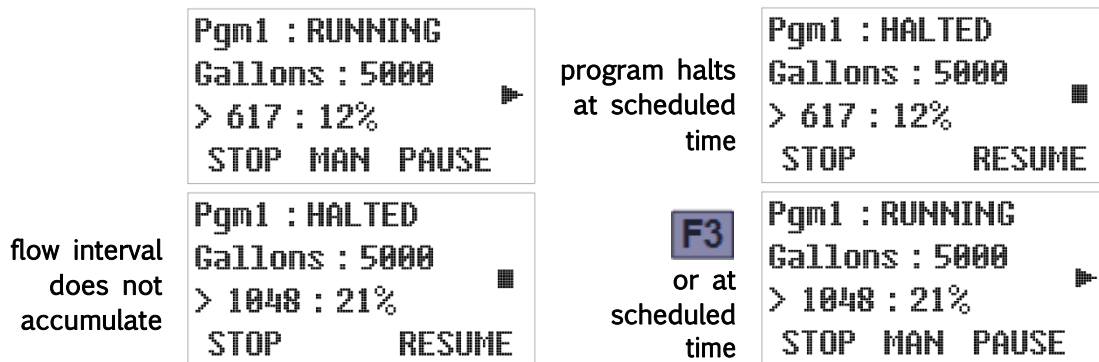

You can stop the program or take manual samples while automatic sampling is paused or halted. If the configured sampling interval reaches 100 percent one or more times, the following screen will briefly appear:



Blocked samples are not drawn when the paused or halted program is resumed.

5.5.1 Grab Sampling

- 1) A Grab sample (volume test sample) can be taken at any time while the program is running. When the program is running, push PAUSE (F3). Then push GRAB (F2) to enter grab mode.

Pgm1 : RUNNING
Time (min.): 60
> 57:00
STOP MAN PAUSE

F2

Pgm1 : PAUSED
Time (min.): 60
> 56:01
STOP GRAB RESTART

- 2) Grab Smpl Size: enter the desired grab sample volume you would like to test. The sample volume that the current program is running will be populated in the volume field.

F3
GRAB SMPL SIZE
(20-500 ml)
> 100_
HOME BACK SEL

Or enter
custom
volume

GRAB SMPL SIZE
(20-500 ml)
> 50_
UNDO BACK SEL

- 3) If the grab sample size is the same as the current program sample size, the screen will display Grab #1 and is ready to take a grab sample.

F3
GRAB #1
Insert Grab BTL
collect sample
STOP START

- 4) If a custom grab volume is entered that is different from the current program sample volume, you may need to calibrate the grab sample volume. A Grab Calibrate screen will require you to complete calibration before taking a grab sample. After calibrated, dispose of the calibration samples.

F3
GRAB CALIBRATE
size: 50 ml
must calibrate
BACK START

F3
CALIBRATE #1
Size: 50 ml
collect sample
STOP START

After
calibration:

F3
GRAB #1
Insert Grab BTL
collect sample
STOP START

F3
GRAB SMPL
finished
restore hardware
CONTINUE

- 5) When Grab sampling is done push STOP (F1), and then CONTINUE (F3). The program will return to the PAUSED screen. Pushing RESTART (F3) will return the program to the Program Run screen. Make sure the discharge arm is directly above the sample bottle when GRAB sampling is completed.

Note

If a grab sample is taken while a program is running, it is not counted as part of the number of samples in the program and is not logged in the log files.

5.5.2: Sample Calibration

Prior to running a program, calibrate the entered sample volume by:

- 1) Go to MAIN MENU and scroll to the CALIBRATE menu item. Press SEL (F3) to select.
- 2) CALIBRATE #1 is displayed. Press START (F3) to take a calibration sample. Discard the sample and proceed to CALIBRATE #2. There is a maximum of 3 Calibration iterations, a CALIBRATION COMPLETE screen displays when the sample is calibrated.
- 3) Discard the calibration samples and press CONTINUE (F3) to exit back to MAIN MENU. Press HOME (F1) to return to the Pgm:READY screen.

Note

If **Calibration Fails**, the velocity control valve may need to be adjusted. Also, make sure the discharge tube is not touching the container. This can cause the calibration to fail as well.



If you skip the above calibration steps, the sampler will automatically calibrate the sample volume after each sample. However, the first three samples may not meet accuracy specification.

5.5.3: Float Suspended Sampling

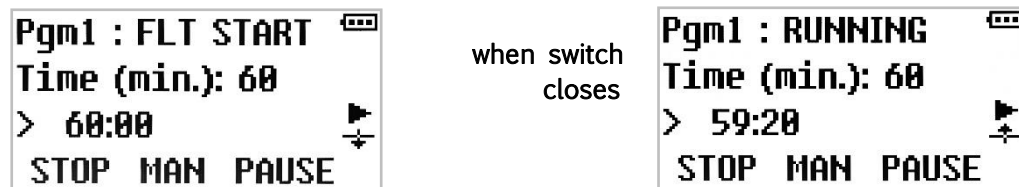
If the Float Option (Chapter 4.6.4) is Enabled and factory-configured (Chapter 2.6.1) to suspend sampling when that input is cleared, the interval counters are held at zero whenever the float switch is open:



Note that the float icon points down when the float-switch circuit is open (sampling suspended) and up when that circuit is closed (sampling resumed). This can be remembered by thinking of this icon as a thumbs-up or thumbs-down indicator:

-  indicates the stream depth is insufficient to sample
-  indicates the stream depth is sufficient to sample

5.6: Stopping the Program

The running program might have been set up to take a specific number of samples and then stop, in which case it would then display the following DONE operating state screen:

```
Pgm1 : RUNNING
Comp: 5 gal.
Smp1#: 167 of 168
STOP MAN PAUSE
```

when final
sample has
been drawn

```
Pgm1 : DONE
>Pgm Complete
>Normal
RESET
```

Prior to resetting the program, you can scroll to the other run-time screens. For example, you could go to the screen that tells how many samples were collected.

Alternately, it might have been set to only run for a specified length of time or to stop at a specific, scheduled time. If so, it displays a timed stop icon above the running icon (as shown below) and you can scroll to an added RUNNING screen whose second line shows the time and date at which the program will shut down and display the DONE operating state screen:

```
Pgm1 : RUNNING
18:00:00 07/09/15
12:34:56 07/08/15
STOP MAN PAUSE
```

when scheduled time arrives

```
Pgm1 : DONE
>Pgm Complete
>Normal
RESET
```

In either case, the program can be prematurely stopped by pressing the STOP [F1] key, after which it would then display its STOPPED screen:

F1

```
Pgm1 : STOPPED
>Pgm Stopped
>From Keypad
RESET
```

The RESET prompt indicates you cannot restart the program until you press the F1 key to zero its interval and container volume counters and advance it to its READY state.

5.6.1: Continuous Operation

If the Bottle Limit option (Chapter 4.6.6) is set to “Program Continue”, the program will ignore its samples per bottle setting and continue sampling indefinitely, without requiring anyone to ever press the RESET [F1] key.

Because the sampling program will then have no way of knowing how many samples it has discharged since the container was last emptied, the sample count screen (Chapter 5.4.2) will merely indicate “NL” (no limit).

5.7: Reviewing Archived Data

The sampler stores time stamped records of each sample they are collected, separated into individual log files for each sampling run (i.e., one log file for each time any sampling program has been run).

That archived data can be reviewed from the user interface panel by pressing the **5** key when the selected program is running (or waiting to be started), but not while the Administration or Program menu is active. The first line of the resulting display will indicate you are viewing log file 1, in which data for the current (or pending) sampling run is being (or will be) recorded:

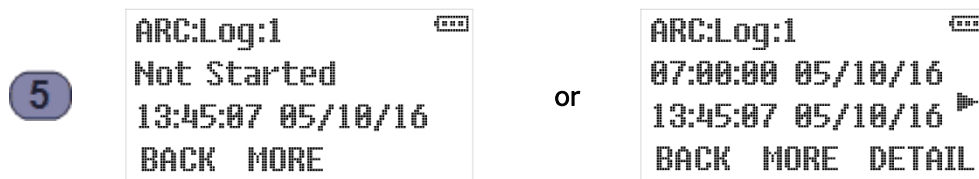

The second line of that display indicates the date and time at which the selected program was started, while the third line displays the date and time at which you started viewing its log file. For example, the screen shown to the left above indicates the currently running program was started at 7:00 AM on May 10, 2016, and the data archive was opened at about 1:45 PM that same day. If the program had not yet been started, the screen shown to the right above would be displayed.

- ⚡ *The icons along the right edge of the screen will continue to indicate the current status of the selected program (see Table 5-1 Chapter 5).*
- ⚡ *The DETAIL prompt for the F3 key appears only for log files that contain one or more sample and/or exception records.*

Pressing the Down arrow would then access the first log file screen for the second-most recent sampling run (log 2) and display the times and dates at which that sampling run was started and stopped. For example, the display shown to the left below indicates the prior sampling run was initiated at 7 AM on May 9, and concluded about 12 hours later:

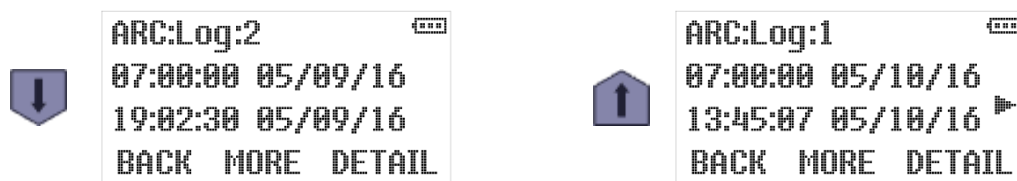

You can use the Up and Down keys to scroll through the available log files. Pressing the Up key while viewing the newest will access the oldest and pressing the Down key while viewing the oldest will access the newest. The sample screen shown to the left below indicates 42 log files are currently available, the oldest of which was recorded on March 14, 2016:

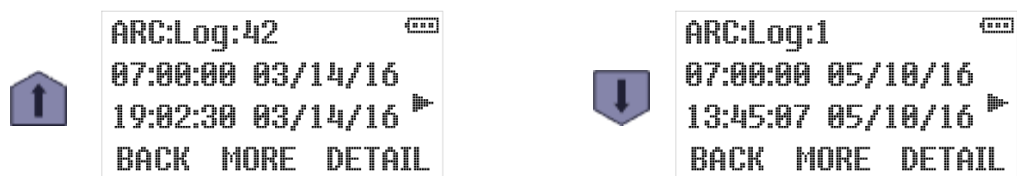

- ⚡ *Use the Administration Menu's Clear Archive option (Chapter 3.2.4) to erase the log files.*

Press the MORE [F2] key repeatedly to view the following additional information about each log:

F2	<pre>ARC:Log:1 07:00:00 05/10/16 12 smp1s rc BACK MORE DETAIL</pre>	<p>number of samples collected (rc appears only if some samples required recycling)— this example indicates the sampling run that commenced at 7:00 AM on May 10 collected 12 samples]</p>
F2	<pre>ARC:Log:1 Composite 1 5 gal. BACK MORE DETAIL</pre>	<p>type, number and size of the containers to which those samples were discharged</p>
F2	<pre>ARC:Log:1 07:00:00 05/10/16 2 excepts BACK MORE DETAIL</pre>	<p>number of exceptions that occurred during that sampling run (the DETAIL prompt for the F3 key appears only if it is not zero)</p>
F2	<pre>ARC:Log:1 07:00:00 05/10/16 2 recycs. BACK MORE DETAIL</pre>	<p>number of times the incomplete sample recycling feature was triggered during that sampling run (the DETAIL prompt for the F3 key appears only if it is not zero)</p>

Pressing the DETAIL [F3] key while viewing any of a log file’s first three screens will display the number of samples and total volume of wastewater it deposited into its first (or only) sample container. For example:

F3	<pre>ARC:Bot:1 3 smp1s 600 ml rc BACK MORE DETAIL</pre>	or	<pre>ARC:Bot:1 12 smp1s 2400 ml rc BACK DETAIL</pre>
-----------	---	----	--

Where the rc notation will be present on the third line only if the incomplete sample recycling feature was triggered for at least one of the samples deposited into that bottle. The left screen above is displayed by sequential samplers, in which case repeatedly pressing the MORE [F2] key would reveal how many samples were deposited into each of the other sample containers. The right screen, which does not display the MORE prompt, is displayed by composite samplers.

Pressing the DETAIL [F3] key while any sample container’s screen is active would display the time stamp and actual weight of the first sample discharged to that container. You could then display the same information for each of the other samples in to that container by repeatedly pressing the Up and/or Down keys:

F3	<pre>ARC:B1:S1 08:00:00 05/10/16 200 ml BACK</pre>	↑	<pre>ARC:B1:S2 09:00:00 05/10/16 200 ml rc BACK</pre>
-----------	--	---	---

The example screens shown above indicate the first two samples were drawn at 8:00 and 9:00 AM, respectively. The “rc” notation on the sample 2 screen indicates the programmed volume was not fully obtained on the first attempt, thus triggering the incomplete sample recycling feature.

If a log file's fourth screen indicates one or more exceptions were encountered, pressing its DETAIL [F3] key will display the timestamp and type of the first such exception detected during that program run. For example:



Where the screen shown to the left indicates that the program run that commenced at 7:00 AM on May 10 encountered two exceptions. The screen on the right indicates the first of them was an electrical power loss at about 9:25 AM on that same date.

If a log file's fifth screen indicates one or more samples required more than one vacuum phase to collect the intended volume, pressing its DETAIL [F3] key will display the record for the first such sample. You could then display the records for the other recycled samples by repeatedly pressing the Up and/or Down keys. For example:



Where the screen shown to the left indicates two of our example program run's sample cycles needed more than one vacuum phase to fill the sample chamber. The screen on the right indicates the first such sample cycle was initiated at about 4:00 PM.

Chapter 6: Maintenance

Refrigerated QLS samplers are designed to be nearly maintenance free, but routine cleaning and temperature verification is advisable, thermostat adjustment might occasionally be needed, and some parts might eventually wear out. Failed parts can be returned to the factory for repair or replacement, or you can order replacement parts using the numbers listed in Appendix B:

This section describes how to maintain your sampler. If you think your sampler requires repair, or if you have questions concerning its operation or maintenance, contact your authorized Teledyne ISCO service facility or Technical Service Department:

Phone: (800) 228-4373
(402) 464-0231
FAX: (402) 465-3001
E-mail: IscoService@teledyne.com

6.1: Periodic Maintenance Checklist

Perform maintenance as needed.

- Clean or replace the wetted parts (bottles, suction line, strainer, sample chamber, discharge tube).
- Clean the sampler when needed.
- Keep the refrigeration air vents clean.

6.1.1: Sample Chamber Removal

- 1) Unscrew the two white hose fittings on top of the sample chamber and disconnect the hoses.
- 2) Use the lever to loosen the set collar.
- 3) Lift the sample chamber out of the collar (discharge hose will come out with the chamber)

6.1.2: Cleaning the Sample Chamber

- 1) Stop or Pause the program
- 2) Remove the chamber from the sampler.
- 3) Remove the 10 screws that hold the lid and chamber body together.
- 4) Place the chamber parts into warm soapy water.
- 5) Clean the chamber parts using a brush or sponge.
- 6) Assemble the chamber using the screws. Be sure that the seal is properly seated.
- 7) Install the sample chamber back into the unit.

6.1.3: Sample Chamber Installation



Graduation marks on this side

- Upon installation of the chamber, it is important that the fittings are oriented in opposite directions as shown below. Note, make sure the chamber is properly oriented with the graduation (volumetric) marks facing the sampler door

Note

opening.

Improper installation of the chamber and tubing can cause the load cell to improperly weigh the sampler and will affect volume accuracy.

- Install the tubing (WW050) onto the chamber discharge fitting and secure it with a cable tie.

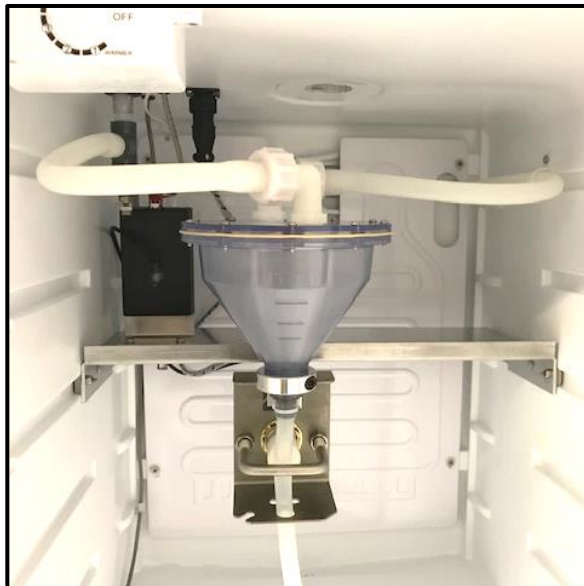

- Fit the sample chamber into the pinch valve's set collar as shown. Orient the graduation marks on the sample chamber body toward the front of the sampler. Tighten the set collar using the lever.
- Connect the vacuum/pressure tubing coming from the upper wall to the front sample chamber fitting. The tubing should make a loop but it should not touch the wall.
- Install the intake (longer) tubing onto the back sample chamber fitting as shown. Orient the tubing so its natural bend is in the direction shown. Adjust the tubing so there is no tension or kinks in the section of tubing between the sample chamber and the tube retainer. Make sure the tubing does not touch the back wall of the cabinet.

6.1.4: Cleaning or Replacing Wetted Part

For general cleaning, you can wash the strainer and sample bottles with a brush and warm soapy water, then rinse with clean water. You can clean the liquid path through the wetted parts by placing the strainer in a cleaning solution and pumping it through the delivery system. Next, place the strainer in clean water and pump it through the delivery system to rinse it. If these items are severely contaminated, replace them.

6.1.5: Sampler Cleaning Guidelines

Keeping the sampler clean and protected from harsh elements may extend the usable life of the sampler. When necessary, clean the exterior and interior of the sampler and sample chamber with warm soapy water and brush, and then rinse with water. Be sure to use a detergent that is compatible with low-density polyethylene, polystyrene, PVC, ABS, polycarbonate and NORYL™. Avoid using strong solvents and acids.

6.1.6: Verifying the Temperature

The sample compartment temperature is displayed by the fifth operating state screen (Chapter 5.4) and periodically recorded in the archival data. Although that measurement is calibrated at the factory, it can drift over time. So a calibrated refrigeration thermometer should periodically be used to determine how close the sampler's measurement is to being accurate and how close the sample compartment is being kept to the desired temperature.

If the actual temperature differs unacceptably from its desired value, you will need to adjust the thermostat's set point up or down accordingly (Chapter 6.2.1).

6.2: Refrigeration System Maintenance

The refrigerator is an indoor unit only. Install the unit in a dry location and the ambient temperature range is between 35° and 100° F. If the ambient temperature is above or below this range, the performance of the unit may be affected. The refrigerator can be cleaned with warm water soapy water. Any spills inside the refrigerator needs to be cleaned as soon as possible.

The refrigerators copper tubing is coated with a phenolic resin to resist hydrogen sulfide (H₂S) corrosion. However, the high concentrations of that gas present in some areas of a wastewater treatment facility can still create pin-hole leaks after as little as a year or two of exposure.

Please take care to avoid areas of high H₂S concentration and place the sampler in favorable positions to avoid excessive exposure to corrosive gases. Since hydrogen sulfide is heavier than air, place the sampler in higher elevation to protect from corrosion damage.



Figure 6-4: Refrigeration Thermostat

6.2.1: Adjusting the Thermostat

The thermostat is located inside on the upper left side and can be adjusted by turning the control knob. The temperature setting is from 1 to 6, with six being the coldest.



6.3: Compressor/Vacuum Pump

Each sampling system is equipped with one continuous-duty, permanently-lubricated, piston compressor/vacuum pumps that provide long-term consistent sampling with vertical lifts up to 28 feet. *These pumps need no routine maintenance.*

The pump and its 4-way solenoid valve are mounted on a metal plate behind the sampler's upper rear access panel (as shown above). If your pump's performance declines unacceptably, replacement pumps and service/rebuild kits (including instructions) can be obtained from Teledyne ISCO.

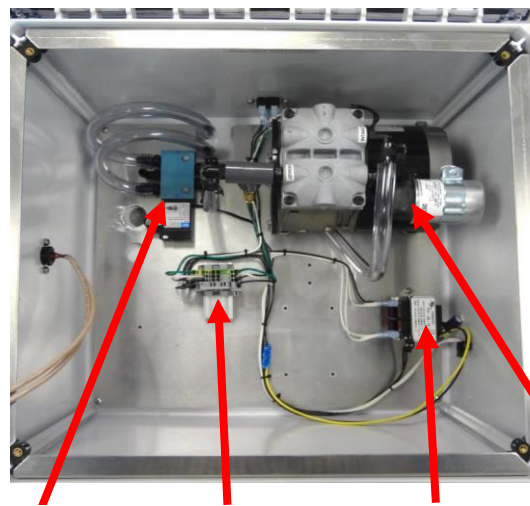

Solenoid Valve 10 Amp Fuse Transformer Vacuum Pump

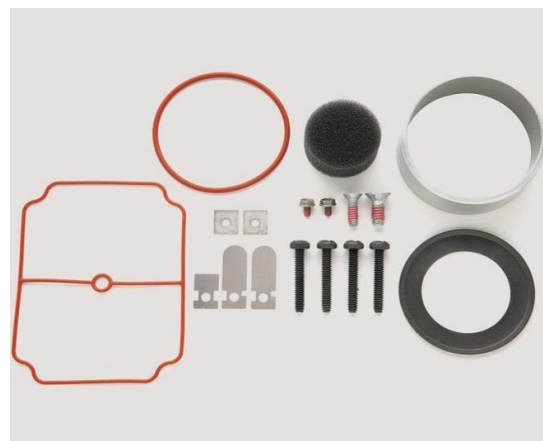
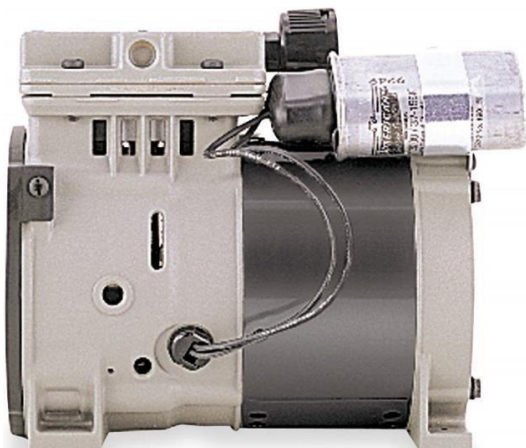

Figure 6-7: Quick Lift Compressor/Vacuum Pump and Service Kit

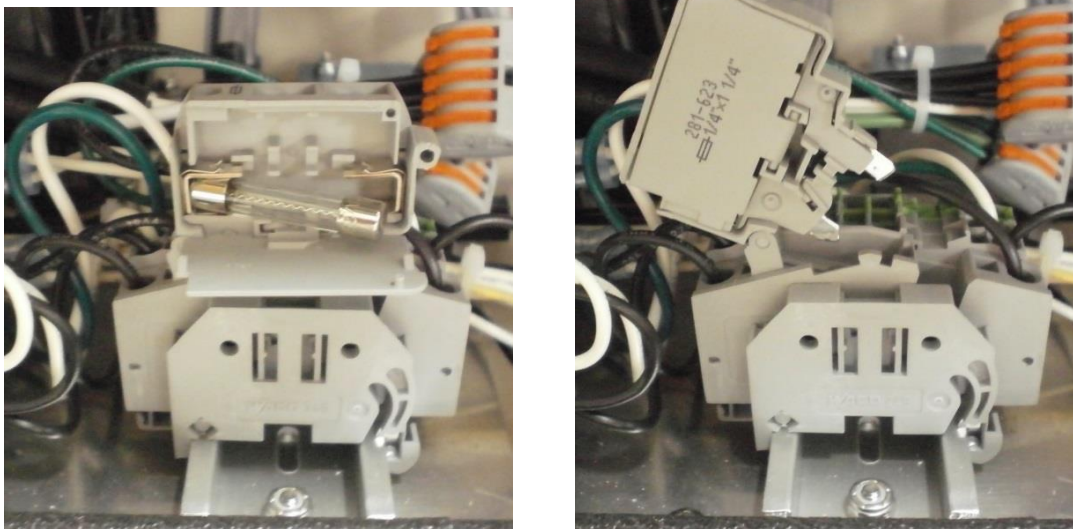

Figure 6-8: Control system fuse holder in open and tripped positions

6.4: Control System Fuse

The control system operates on 12 VAC power supplied by a transformer located in the vacuum pump compartment. Those components are protected by a fast-acting, 10A/250 V cartridge fuse whose enclosed holder is mounted next to the transformer.

As shown above:

- That fuse can be checked and/or replaced by pulling the front cover of that holder forward and down, which automatically ejects the right end of the fuse.
- The control system can be powered down by tipping the top of the holder up and to the left.

6.5: Troubleshooting Tips

Use the following suggestions to troubleshoot the listed problems.

1: User interface panel is dark:

- a) Press any key to turn backlight on (it turns off after two minutes of inactivity).
- b) If the screen is still dark but you can make out that it is displaying information, use the Administration Menu to adjust the backlight (Chapter 3.2).
- c) If the screen is uniformly black, make sure the sampler is powered up (you should be able to hear the fan circulating air through the sample compartment).
- d) Check the control system fuse (Chapter 6.4)
- e) Reboot the controller by briefly tripping that fuse or unplugging the sampler.
- f) If the controller is powered but its interface panel is black, the logic board is probably defective; call Teledyne ISCO for technical assistance.

2: One or more buttons never work:

- a) The logic board is malfunctioning; call Teledyne ISCO for technical assistance.

3: Readout never changes and cannot be scrolled:

- a) Reboot the controller by briefly unplugging the sampler.
- b) Controller hardware or software is faulty; call Teledyne ISCO for technical assistance.

4: Readout indicates program will automatically start at midnight, 12/31/99

- a) Stop the selected program and disable its Automatic Rerun parameter.

5: Readout indicates the load cell cannot be initialized:

- a) Check the load cell controller's plug-in connection
- b) Call Teledyne ISCO for technical assistance.

6: Readout indicates an indexing error

- a) Make sure the bottle carousel is properly installed and is free to rotate.
- b) Check the wiring for the sequential sampling turntable.

7: Readout indicates sampling failures—too little (if any) wastewater is collected:

- a) Check the intake strainer and tube for obstructions and make sure the intake strainer is fully submerged.
- b) Make sure the intake line is properly connected to the sampler's intake port. If a compression fitting is used, the ferrule must be properly positioned and the nut properly tightened.
- c) Make sure the pinch valve is energizing and seals the discharge tube when it does.
- d) Make sure the vacuum pump and solenoid are depressurizing the sample chamber.
- e) Check for vacuum line leaks.
- f) Adjust the velocity control valve for more vacuum.

8: Samples are too large and/or wastewater is drawn into the pump:

- a) Make sure line conditioning rinses are not drawing water into the sample chamber.
- b) Make sure the sample chamber empties completely after each sample.
- c) Adjust the velocity-limiting valve (Chapter 2.3).
- d) Make sure the sample chamber and its discharge tube can rise and fall freely. The discharge tube must not contact anything it passes through or past, such as the hole (if any) in the lid of the sample container.

9: Purging does not clear the intake line:

- a) Make sure the pinch valve is energizing and seals the discharge tube when it does.
- b) Check the intake strainer and tube for obstructions.
- c) Make sure the vacuum pump and solenoid are pressurizing the sample chamber.

10: Sampling continues despite full or over-flowing container(s):

- a) Verify that the Bottle Limit option (Chapter 4.6.6) is set to "Program Stop". If you deliberately set it to "Program Continue", the program will overflow the sample containers if you fail to replace them in a timely fashion.
- b) Make sure your Bottle Options (Chapter 4.5) settings match the installed sample containers. If you specified a larger container size than you are actually using, and the number of samples per bottle you specified will not fit in the installed container, the program will overflow it.
- c) Verify that samples of the intended size are being drawn (see item 8:).

11: Sample compartment temperature is too high or low:

- a) Verify that the refrigerator is cycling.
- b) Verify that the displayed temperatures are correct.
- c) Adjust the thermostat set points.
- d) Make sure the door is closed and latched.

If the sample compartment is too warm, verify the evaporator plate is warm and the compressor is running (may be hot to touch). The refrigerator may be low on Freon.

Appendix A: Controller Capabilities

This appendix describes the capabilities of the sample control system firmware, in order to help you decide how best to adapt it to the needs of your sampling application.

A.1: Overview

The control system consists primarily of six **sampling programs** and a **supervisory routine** that executes when the sampler is first powered up and whenever the selected program is stopped.

A.1.1: Supervisory Routine (Ready State)

When the sampler is powered up, the supervisory routine briefly displays the installed firmware version number and revision letter (e.g., Version xx Revision xx). It then indicates the controller is Ready to run. While it is operating in that state, the user interface panel can be used to:

- start the selected program immediately,
- start that program, but delay its execution to a specified future date and time-of-day, or
- display its administration and configuration menus, in order to:
 - set the sampler's configuration password and ID number, adjust its real-time clock and display panel, and manage its archival data;
 - select and configure the control program; and
 - set up certain hardware and menu system features (Teledyne ISCO personnel only).

Once the selected program has been started, the menu system functions are unavailable until it stops (or is stopped)—at which time the controller returns to its supervisory/Ready state.

- ⚠ The controller administration and program configuration functions are not available while the sampling program is running.

A.1.2: Menu System Outline

The following outline lists all possible Menu System entries. Those that are actually displayed by any given sampler will depend on its hardware features, purchased options, and values assigned to related Factory and Program Menu parameters.

Main Menu

Program Menu

Program Select parameter (1|2|3|4|5|6)

Program Configuration menu (for selected program)

 sampling Cycle group

 Prepurge (seconds)

 Sample Size (milliliters)

 Postpurge (seconds)

 Number of Rinses (0 to 4)

 if > 0:

 Pressure Time (seconds)

 Vacuum Time (seconds)

 Recycle (Enable/Disable)

 Consecutive Samples (1 to 24)

 Sample Intervals group

 Sample Interval (Time/Flow, Time+Flow, Time/Bottle,
 Flow/Bottle) if Time or Time+Flow:

 Time Option (Time Fixed/Time Variable)

 if Time Fixed:

 Sample Minutes

 if Time Variable:

 Sample Minutes list

 if Flow or Time+Flow:

 Flow Type (4-20mA, 0-5V, 0-10V,

 Pulses) if 4-20mA, 0-5V, 0-10V:

 Maximum Gallons [Liters] Per Minute

 Gallons {Liters} Option (Gallons Fixed/Gallons Variable)
 [Liters Fixed/Liters

 Variable] if Gallons [Liters] Fixed:

 Sample Gallons [Liters]

 if Gallons {Liters} Variable:

 Sample Gallons {Liters} list

 if Pulses:

 Flow Option (Pulses Fixed/Pulses
 Variable) if Pulses Fixed:

 Sample Pulses

 if Pulses Variable:

 Sample Pulses list

 if Time/Bottle:

 Bottle Minutes list

- if Flow/Bottle:
 - Flow Type (4-20mA|0-5V|0-10V|Pulses)
 - if 4-20mA|0-5V|0-10V:
 - Maximum Gallons [Liters] Per Minute
 - Sample Gallons [Liters] list
 - if Pulses:
 - Sample Pulses list
- Bottle Options group
 - Sample Type (Composite/Discrete)
 - Composite:
 - Composite Size (options enabled at factory)
 - Samples per Bottle
 - Discrete:
 - Bottle Configuration (options enabled at factory)
 - Number of Bottles
 - Samples per Bottle
 - Index Type (After Bottle/After Sample/After Time/Real Time) if After Time:
 - Index Minutes
 - if Real Time:
 - Index Time (of day)
 - Index Minutes
- Program Run Options group
 - Automatic Rerun
 - Delay Start (minutes)
 - Float Option (enable/disable)
 - Fault Option (enable/disable)
 - Timed Stop (None|24Hour|12Hour|8Hour|Custom)
 - if Custom:
 - Stop Time (minutes)
- Program Events list
 - for each:
 - Program Event
 - (Start/Stop/Sample/Pause/Halt/Resume) Weekdays
 - Time (of day)

Menu System Outline (continued)

Administration Menu

- Set Language
- Set Password
- Clear Password
- Set Daylight Savings Time
- (Winter/Summer) Set Clock (date & time-of-day)
- Adjust LCD
- Download Archive
- Clear Archive
- Set ID
- Set Units (English/Metric)

Main Menu

- Program Menu
- Admin Menu
- Loadcell Menu (ISCO personnel only)
- Calibrate
- Factory Menu (ISCO personnel only)

A.2: Inputs and Outputs

As shown on the Electrical Diagram appended to this manual, the sampling controller has the following required and optional inputs and outputs:

- run-status and alarm output relays (see below)
- a turntable motor control output and two position sensor inputs (see below)
- a sample-compartment temperature input (Appendix A.2.4)
- one analog and one discrete-pulse flow input (Appendix A.2.5)
- a float-switch input (Appendix A.2.6)
- the sample chamber's load-cell controller (Appendix A.2.7)
- pump-motor, solenoid-valve and pinch-valve sampling outputs (Appendix A.2.8)

A.2.1: Run-Status Output

The controller energizes the power board's run-status relay (thus connecting pins 3 and 4 of the optional field I/O connector) as each sampling cycle is initiated, and de-energizes it as that cycle discharges the sample it collected.

A.2.2: Alarm Output

If the power board's alarm relay is enabled (Chapter 4.6.3), the controller energizes it (thus connecting pins 5 and 6 of the optional field I/O connector) when:

- the sampling program is waiting to be reset after completing normally, being manually stopped, or failing to determine the position of the sequential-sampling turntable;
- sampling has been suspended because the float input circuit is open, as discussed below (this will also be indicated by displaying a fault icon along the right edge of the screen);
- the most recent sample cycle failed to determine the sampling chamber's tare weight, or failed to collect at least 60 percent of the specified sample volume; or
- the storage compartment has been above its intended temperature for at least 30 minutes (this will also be indicated by displaying a °C icon along the right edge of the screen).

A.2.3: Turntable I/O

The controller uses one discrete output and two discrete inputs to operate the optional sequential-sampling turntable.

- That output starts and stops the turntable's motor by energizing and de-energizing the power board's table control relay.
- Those inputs are wired to sensors that detect the passage of magnets (usually 24) that are radially embedded in the turntable's upper plate. The H sensor is positioned to detect the turntable's single home-position magnet, while the S sensor detects the others.

All three circuits are wired to a seven-pin CPC mounted in the roof of the sample compartment.

A.2.4: Temperature Input

The refrigerated samplers are equipped with resistive temperature devices (RTDs) that the controller uses to measure the sample compartment temperature. Each RTD is mounted inside the refrigerated cabinet on the side wall and connected directly to the logic board's temperature input port. The cabinet temperature is logged with each sample in the Data Archive log files.

A.2.5: Flow Input

The controller provides one analog and one discrete input that are meant for connecting flow meter signals. All Refrigerated Samplers are equipped with four-pin circular plastic connectors (CPC) that provide terminals for both of those inputs.

Connecting either type of signal allows you to configure flow interval counters (see page 104) that will initiate samples as the total flow in the sampled stream passes specified volumes. Or, the pulse input can be used to remotely trigger the collection of individual samples (see below):

To do that, you must set parameter(s) that specify the connected signal type (4-20 mA, 0-5 VDC, 0-10 VDC, or discrete pulse):

- If an analog flow-rate signal is connected, you must also specify the flow rate (in gallons) corresponding to its maximum value (20 mA, 5 VDC or 10 VDC) and the desired flow intervals in gallons. The controller then integrates that signal to determine the accumulated flow and draws samples at the specified intervals.

✎ *Multiple devices can be connected in series to a 4-to-20 mA transmitter, provided they do not share a common ground and their summed resistances don't exceed the transmitter's capacity. **The internal resistance of our sampler's current-loop input is 250 ohms.***

- The discrete signal type is intended to be used with a flow meter that integrates its own flow rate measurement and pulses an output relay on and off at specific accumulated flow intervals. If you connect such an input signal, you need only specify the number of pulses corresponding to the flow intervals at which samples are to be drawn.

Assuming you really want your samples to be drawn at flow volume intervals, you can calculate those counts by dividing the desired flow intervals (in volumetric units) by the incremental flow (in the same units) that triggers each meter relay pulse.

For example, assume the meter pulses its output relay once for every 1000 gallons of stream flow, and you want to sample that stream at 25,000 gallon intervals. You should then set the interval duration to 25 pulses per sample (25000 gallons per sample divided by 1000 gallons per pulse).

A.2.5.1: Remote Sample Initiation

Alternately, you can repurpose the pulse input to initiate a sample each time its circuit is closed by a connected PLC or other external device, effectively allowing such a device to remotely trigger the collection of individual samples:

- 1) Select either the Flow or Time+Flow sampling interval option.
- 2) Set the Flow Type parameter to Pulses.
- 3) Set the Flow Option parameter to Pulses Fixed.
- 4) Set the Sample Pulses parameter to 1.

A.2.6: Float Input

The controller provides one internally-powered discrete input that can be connected to an external stream-level float switch. The controller can then be configured (see below) to draw samples only while or after that input circuit has closed. Thus:

- If a stream-level float switch is connected, it should close as the stream level rises above an appropriate minimum level. The sampler could then be configured to draw samples only when the stream depth was sufficient to cover the intake strainer (or above some other appropriate threshold).
- More generally, this is essentially a remote run-permissive input that could be connected to any appropriate field device or PLC relay output.

A.2.6.1: Factory Menu Float Setting

If the Float Option (Chapter 4.6.4) is Enabled and its input circuit is open when the control program is started, the unit will not start drawing samples until the float switch circuit is closed. If that circuit opens after sampling has begun, the program's response will depend on its Factory Menu FLT setting (which is set to your specifications before the unit is shipped):

- If the FLT START/STOP setting is selected, the program will reset its sampling interval counters and not restart them until the float circuit closes again (i.e., those counters will restart from zero when the water level rises high enough to reclose the float switch).
- If the FLT START setting is selected, the program will continue sampling without interruption even if that circuit reopens.

If the FLT OFF setting is selected, the float input is disabled and the Program Menu's FLOAT INPUT parameter is hidden.

A.2.7: Load Cell Controller

Each sample cycle vacuums wastewater into the sample chamber until its load cell signals that the programmed amount of liquid has been collected, as detailed in the QLS Sampling Cycle section on page 101. That device has its own control box, mounted in the sample compartment, which attaches to the controller's SDI-12 communication port.

A.2.8: Sampling Outputs

Three electrically-actuated devices control the flow of air and wastewater into and out of the sample chamber (as illustrated above). As shown on the appended Electrical Diagram, each of those devices is controlled by a relay on the controller's power board:

- The Pump relay turns the compressor/vacuum pump motor on at the beginning of each sampling cycle, and off after the collected sample has been discharged.
- The Solenoid relay energizes and de-energizes the four-way solenoid valve that alternately connects the sample chamber to that pump's the vacuum or pressure port.
- The Pinch relay energizes the pinch valve solenoid to seal off the chamber's discharge tube during all but the final (discharge) phase of the sampling cycle. That valve connects to it via a 2-pin CPC in the roof of the sample compartment.

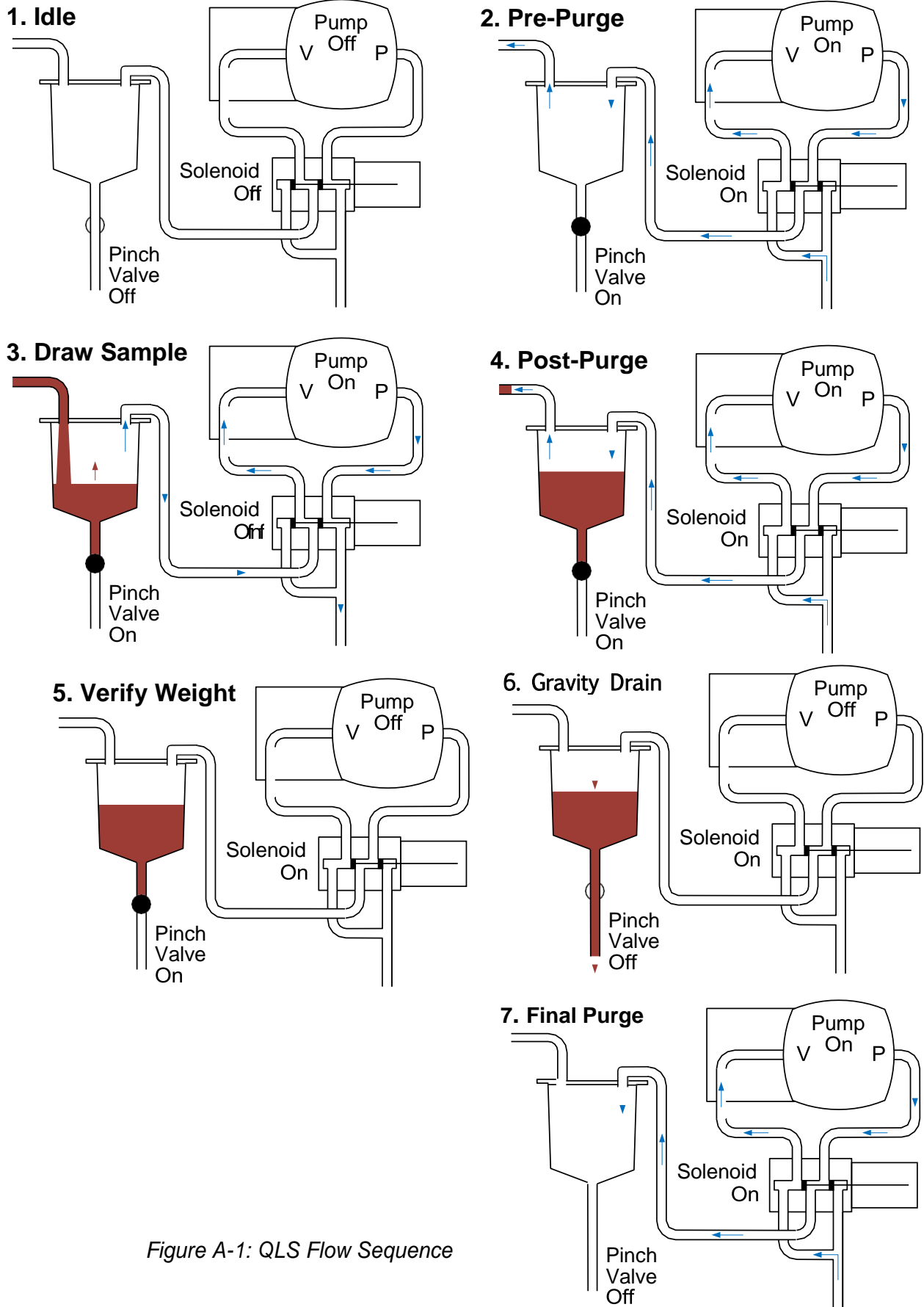

Figure A-1: QLS Flow Sequence

A.3: Sampling Program

The sampling programs all use the same underlying instructions but can be configured (via the Program Menu) to provide very different features sets. Each can be set up to:

- draw configurable, fixed-size (20 to 500 milliliter/gram) samples, or sets of consecutive samples, at specified time or flow intervals;
- rinse the sampling line up to four times prior to drawing each sample;
- repeat any sampling cycle up to four times (five total) if needed to collect the specified volume of wastewater;
- discharge each sample into a specified bottle (sequential samplers only), keeping track of the volume discharged to each to avoid overfilling them;
- delay its execution a specified number of minutes after it is started, or until the optional float input is asserted (or pause and resume repeatedly as that input is set and cleared);
- automatically stop after a configurable amount of time or number of samples; and
- start sampling, pause or halt and later resume, take manual samples and finally stop at scheduled times on specified days of the week, then automatically restart itself if desired.

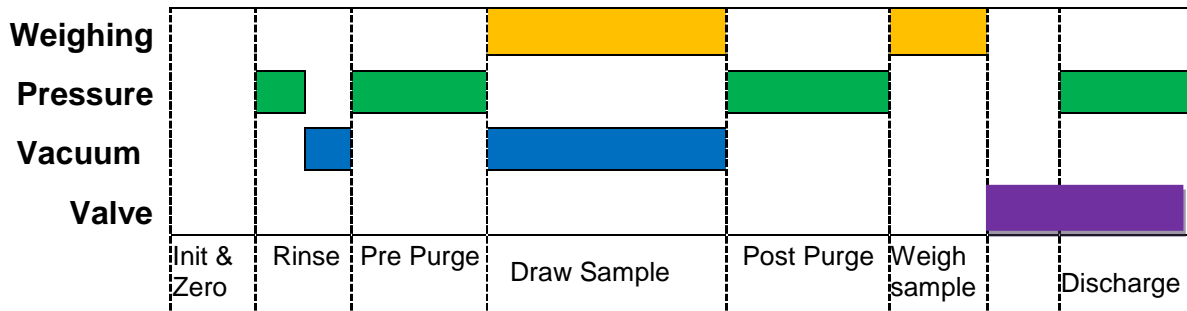

Figure A-2: QLS Sampling Cycle

A.3.1: QLS Sampling Cycle

The figures above and on the preceding page illustrate the full QLS sampling cycle, which can be configured to include up to four optional **rinse** cycles (one is shown) and an optional **pre-purge** step (also shown):

- 1) As each sampling cycle is initiated, the load cell is initialized, and the empty chamber is weighed. That tare weight is subtracted from the load cell measurement to zero it.
- 2) The sampling tube and strainer are optionally rinsed up to four times and then “pre-purged” to clear out accumulated water and debris:
 - The prepurge pressurizes the sample chamber for a specified number of seconds, which will presumably clear the intake line. It is rarely disabled.
 - It can be preceded by up to four rinses, each of which first pressurizes the chamber to blow out the line and then sucks a limited amount of water into it. The pre-purge phase would then blow out the water drawn in by the last rinse.
- 3) The chamber is depressurized for up to 100 seconds to draw wastewater into the chamber.

⚠ *When configuring the optional rinse phase, do not make it so long that water is drawn into the sampling chamber. If it was, it would limit the minimum size of the sample and might even result in the chamber overflowing into the pump.*

- 4) The chamber is “post purged” for a specified number of seconds to stop the flow and clear at least the portion of the sampling tube that weighs on the load cell, so the sample can be accurately weighed.
- 5) The weight of the sample is then determined.
- 6) If sample recycling is enabled and the sample is more than 40 percent below its intended weight, the above steps will be repeated up to four times.
- 7) The final weight of the sample is recorded and the cycle is recalibrated.
- 8) If the unit is equipped with a sequential-sampling carousel, it is rotated to position the intended bottle beneath the discharge tube.
- 9) The sample is then discharged by blowing air into the chamber (which will create only a slight positive pressure because the tube has been purged) and then opening the discharge pinch valve.
- 10) If duplicate sampling has been set up, this procedure immediately repeats the specified number of times, discharging each consecutive sample into the next available sequential-sampling bottle.

A.3.1.1: Automatic Calibration

In order to consistently draw samples of the specified size, the sampling cycle automatically recalibrates itself using the following procedure:

- 1) The sample chamber’s tare weight is determined at the start of each sampling cycle.
- 2) Each sample is continuously weighed as it is drawn into the chamber.
- 3) When its net weight equals the configured sample size less a calibration factor calculated from previous samples, the chamber is “post purged” (i.e., briefly pressurized) to stop the flow as quickly as possible. The weight of the additional wastewater that enters the chamber while the flow is being reversed will ideally equal the calibration factor.
- 4) The sample is then reweighed and recorded. If it differs from the specified sample size, the calibration factor is recalculated.

The previous sample data this process uses is cleared any time the sample size changes.

A.3.1.2: Calibrate Menu

The sampler can deliver sample volumes repeatable to ± 4 ml or $\pm 5\%$ of the average volume in a set. For accurate sample volumes the sampler uses a load cell to give weight measurement feed back to the controller.

- 1) To properly calibrate the volume prior to running a program, you must go to **ADMIN MENU** and scroll to find the **CALIBRATE** menu item. Press F3 SEL to select the menu item.
- 2) Calibrate #1 is displayed, press START (F3) to take a calibration sample. Discard the sample or proceed to Calibrate #2. There is a maximum of 3 Calibration iterations, then a Calibration Complete screen displays when the program is calibrated and ready to run.
- 3) Discard the calibration samples and press HOME (F1) to go to Program Ready Screen.

 Note

If you do not calibrate in the above steps 1 or 2, the sampler will calibrate after the first sample is taken. It may take up to three samples to calibrate. The sampler checks calibration after each sample. (Note: If calibration is not done in the above steps the first three samples may not meet accuracy specification).

A.3.1.3: Sample Recycling

Enabling Recycling configures each sampling cycle to repeat its sample cycle up to four times before discharging the accumulated sample if:

- the collected sample does not reach its target weight within the allotted 100 seconds, and
- the final weight is less than 60 percent of the specified sample size.

If the sample was underweight because debris was sucked into and restricted the intake tube, the repeated pre- and post-purging might clear the obstruction and allow the sample to reach its intended weight/volume. If it was underweight because the sampler was sucking air due to an insufficient sampled stream flow, the flow may increase during the recycling process and get a full sample.

In any event, if the final, discharged sample is underweight, a non-fatal fault is indicated and the program keeps running. The fault is cleared the next time a full sample is collected.

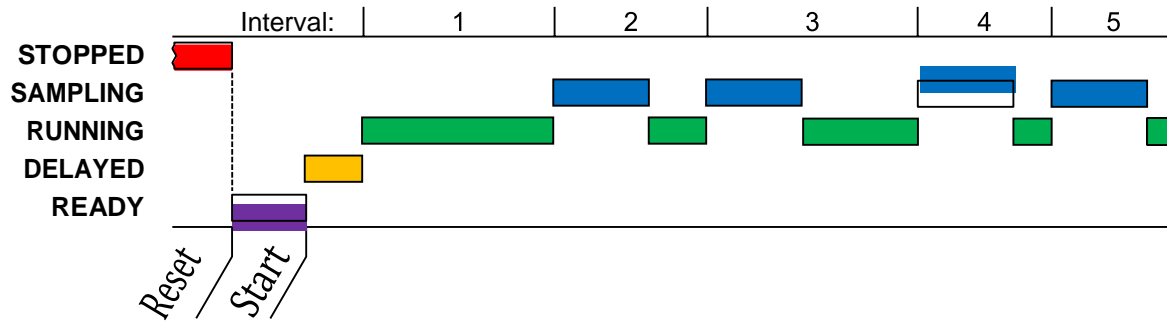

Figure A-3: Basic Sample Timing Diagram

A.3.2: Sampling Intervals

Each program is configured to draw samples in an optionally repeating sequence of up to 24 fixed or variable, time and/or flow-based Sampling Intervals. As shown above, the first interval starts after any configured delay (Appendix A.3.4). At the end of that interval, the program simultaneously triggers its first automatic sample and restarts its interval counter(s). And so on.

The durations of time-sampling intervals are specified in minutes. If any flow-sampling option is selected, a suitable flowmeter must be connected (Appendix A.2.5) and the interval durations are specified in gallons or flow input pulses (each corresponding to a fixed increment in the total flow measured by the meter):

- When **Time** sampling is chosen, the interval lengths (in minutes) can be fixed or vary in a specified sequence.
- When **Flow** sampling is chosen the interval lengths (in gallons or pulses) can be fixed or vary in a specified sequence.
- When **Time+Flow** intervals are chosen, both a maximum time and a maximum accumulated flow interval are specified for each sample. Fixed or variable lengths can be independently set for each. For example, you could specify a sequence of variable flow intervals with a fixed maximum time between samples. When the first of each sample's intervals elapses, its sampling cycle is initiated and both interval counters are restarted.
- When **Time/Bottle** (or **Flow/Bottle**) sampling is chosen, the sampling interval durations can be independently specified for each sequential-sampling bottle (Appendix A.3.3.3).

A.3.2.1: Variable Intervals

Selecting Time Variable (or Flow Variable) interval timing allows you to specify a sequence of up to 24 interval durations.

- Each sample is drawn when the corresponding interval elapses, until the program's stopping criterion is met (Appendix A.3.5).
- If the specified number of intervals is fewer than the number of samples the program is configured to draw, the last of those intervals will be used for all subsequent samples.

For example, if the program is configured to stop after 750 minutes (12.5 hours), and you configure six alternating 2 and 1-hour intervals (i.e., 2, 1, 2, 1, 2 and 1), the sixth interval would be used for the sixth and all subsequent samples. Thus, samples would be drawn after 2, 3, 5, 6, 8, 9, 10, 11 and 12 hours.

A.3.3: Bottle Options

Each program must be “told” how many sample containers it is to use, how big they are, and how many samples it is to put into each container. This is done by configuring the installed **Sampling Type** and then setting the associated **Bottle Options** parameters:

- If a single-container, composite-sampling system is installed, the Composite sampling type must be selected—if you are even given a choice.
- If a multiple-bottle, sequential-sampling system is installed, the Discrete sampling type must be selected.
- ✎ *Each sampler is usually sold with only a Composite or Sequential sample storage system (see page 16). If so, each program is factory configured to use that Sample Type and the Program Menu is set to keep you from changing it. That menu is also factory set to let you select from only the container sizes or bottle carousels you have purchased.*
- ✎ *The maximum number of samples you can specify for each bottle is limited to 90 percent of the selected bottle size divided by the Cycle group Sample Size parameter. Increasing the sample size after the Samples per Bottle parameter has been set might automatically reduce the value of the Sample Size parameter.*
- ✎ *At least one extra container or carousel and set of bottles is usually kept on hand to allow sampling to continue while the filled bottles are readied for reuse.*

A.3.3.1: Composite Sampling

If a single-container, composite-sampling system is installed, the Composite sampling type must be selected. You then specify the size of that bottle and the Number of Samples to be automatically collected and discharged to it:

- The Composite Size setting specifies the size of the sample container.
- The Samples per Bottle setting specifies how many samples will be discharged to that container before the program automatically stops.

A.3.3.2: Sequential Sampling

If your sampler is equipped for sequential sampling, you must select the Discrete sampling type, specify which bottle carousel is installed, and define the criteria for indexing (i.e. distributing) samples among that carousel’s bottles:

- The Bottle Configuration setting specifies the number and size of the bottles in the carousel (for example, 24 Liter specifies a carousel housing 24, 500 milliliter bottles).
- The Number of Bottles setting specifies how many of the available bottles will be used.
- The Samples per Bottle setting specifies how many samples will be discharged to each bottle before the program automatically stops.
- The Index Type setting specifies when the next bottle will rotate into position.

Each program will always discharge its first sample into the bottle in the first carousel position. If Number of Bottles is less than the number actually in the carousel, the difference dictates how many will not receive any samples.

A.3.3.2.1: After-Bottle Indexing

After-Bottle indexing rotates the carousel after each bottle has received the specified number of Samples per Bottle. Thus, the carousel will rotate at most one full turn.

For example, assume a 24-bottle carousel is set for After Bottle indexing, Number of Bottles is set to 20, and Samples per Bottle is set to 5. The program would then collect a total of 100 samples, discharging the first 5 to the bottle 1, the next five to the bottle 2, and so on until samples 96 through 100 were discharged to the position 20 bottle, after which the program would stop. Four bottles would remain empty.

A.3.3.2.2: After-Sample Indexing

After-Sample indexing rotates the carousel each time a sample is discharged, until each of the specified Number of Bottles has received the specified Samples per Bottle. The carousel will thus rotate Samples per Bottle full revolutions. Any manually-drawn samples would count toward the Samples per Bottle limits of the bottles they were discharged to.

For example, assume a 24-bottle carousel is set for After Sample indexing, Number of Bottles is set to 20, and Samples per Bottle is set to 5. The program would then collect a total of 100 samples, rotating the carousel 5 full turns. The first sample would be discharged to the bottle in position 1, the second to the bottle in position 2, and so on until sample 20 was discharged to the bottle in position 20. Bottle 1 would then be rotated into position to receive sample 21, skipping the last four bottles. Sample 22 would be discharged to bottle 2, and so on until the 40th sample was discharged to bottle 20. This would repeat until sample 100 was discharged to bottle 20, after which the program would stop.

A.3.3.2.3: After-Time Indexing

After-Time indexing type rotates the carousel in regular, timed steps whose duration is specified by the Index Minutes parameter. The first indexing interval begins when the sampling interval counters are initiated.

At the end of the first indexing interval, the second bottle is rotated into position and the sampling interval counters are reset. The second bottle is then serviced for Index Minutes, after which the third is rotated into position and the sampling intervals are again restarted. This continues until the specified Number of Bottles have been serviced.

An additional run-time screen is provided which displays the duration of the indexing interval and counts up to the next turntable rotation.

If any bottle receives the specified maximum Samples per Bottle before its indexing interval elapses, no further samples will be drawn until the next bottle is rotated into position.

A.3.3.2.4: Real-Time Indexing

Real-Time indexing is the same as After-Time indexing, except that it rotates the second bottle into position at a specified Index Time (of day).

Ideally, the program would be started (or set to automatically start) Index Minutes prior to the specified Index Time, so the first and each subsequent bottle would be used for Index Minutes. For example, if Index Minutes is set to 1440 (24 hours) and Index Time is set to midnight on January 2, sampling would ideally be started at midnight on January 1. The indexing counter would then immediately start at 0 and count up to Index Minutes:

- If the program is started more than Index Minutes before the specified Index Time, the displayed indexing counter will not start until the time remaining until Index Time is equal to Index Minutes.
- If the program is started less than Index Minutes before Index Time, that counter starts with an initial value greater than zero (essentially Index Time minus Index Minutes).

Real-Time indexing is the same as After-Time indexing, except that it rotates the second bottle into position at a specified Index Time (of day). The displayed indexing interval counter does not start until Index Minutes prior to the specified Index Time.

A.3.3.3: Per Bottle Sampling

If your sampler is equipped for sequential sampling, its programs can progress through a sequence of sampling intervals as each bottle is rotated into position:

- To set a different time sampling interval for each bottle, set the Sample Interval parameter to Time/Bottle. Then define the interval for each bottle by setting the corresponding element in the Bottle Minutes list.
- To set a different flow sampling interval for each bottle, set the Sample Interval parameter to Flow/Bottle. Then define the interval for each bottle by setting the corresponding element in the Bottle Gallons or Bottle Pulses list.

You can set up to 24 such intervals (one for each bottle in a 24x500 carousel), but might not need to:

- The Number of Bottles value you entered (Appendix A.3.3) is the maximum number of intervals you might need to set.
- If you define a lesser number of intervals, the last one you do set will be used for all subsequent bottles.

For example, if the program is configured to use six bottles, and you set a total of four alternating 2 and 1-hour intervals (i.e., 2, 1, 2, 1), that fourth interval would be used for the last three bottles:

- Samples discharged to the first bottle would be drawn at 2-hour intervals.
- Samples discharged to the second bottle would be drawn at 1-hour intervals.
- Those discharged to the third bottle would again be drawn at 2-hour intervals.
- All remaining samples would be drawn at 1-hour intervals (bottles 4, 5 and 6)

A.3.3.4: Duplicate Sampling

If your sampler is equipped for sequential sampling, its programs can be configured to save samples to multiple bottles at essentially the same time by:

- assigning the Cycle group's Consecutive Samples parameter a value greater than one, and
- setting the Bottle Options group's Index Type parameter to After Sample.

For example, assume a 24-bottle carousel is set for After Sample indexing, Number of Bottles set to 24, Samples per Bottle set to 1 and Consecutive Samples is set to 3. Each time the interval counter elapsed, three samples would be drawn as quickly as possible and discharged to the next three empty bottles.

Assuming no manual samples were drawn, the first three samples would be drawn in quick succession and discharged to bottles 1, 2 and 3. The second three would be discharged to bottles 4, 5 and 6, and so on until the sixth set of three samples were drawn and discharged to bottles 22, 23 and 24. The program would then stop.

If a manual sample was drawn after the second set of three automatic samples, it would be discharged to bottle 7 and the third set of samples would be discharged to bottles 8, 9 and 10. Assuming no more manual samples, the fifth set of automatic samples would go into bottles 20, 21 and 22. The sixth set could only discharge 2 samples—to bottles 23 and 24. The program would then stop.

A.3.4: Delayed Starting

The selected sampling program can be started by pressing either the START [F1] or TIMED [F2] key while the controller is in its Ready state (i.e., when the supervisory routine is running):

- Pressing START[F1] starts the program immediately.
- Pressing TIMED [F2] prompts you to specify the date and time at which the program will appear to start. Until then, it will operate in a Timed state in which the sampling interval counters do not run but you can initiate manual samples. An additional run-time screen will display the date and time at which the program will “start”, along with the current time and date. When that time comes, the program will proceed as if you had just pressed the RUN [F1] key.

If one or more Program Start events (Appendix A.3.6) have been configured, the program will also enter its Timed state when the START [F1] key is pressed. It would then proceed as if you had just pressed the RUN [F1] key when the first scheduled start time arrived.

In either case, the sampling interval counters might be further delayed:

- If the program has been set to wait for a Float input (Appendix A.2.6), it will not start its interval counter(s) until that input is asserted. Until then, the program will display its operating state as FLT START.
- If a non-zero value (up to 9999 minutes) has been assigned to the Delay Start run Option (Chapter 4.6.2), the first sampling interval will be further delayed by that many minutes (see Figure A-3 Appendix A.3.2). Until then, the program will display its operating state as DELAYED.

A.3.5: Timed Stopping

Once a sampling program has started, it will continue running until it has drawn the number of samples specified by its Bottle Options unless:

- it is stopped by pressing the STOP [F3] key,
- its Timed Stop Run Option (see page 61) has been set to stop it a specified number of hours or minutes after the program was started, or
- Stop Program events have been configured it to stop at configured times on specified days of the week (see next section).



If either a Timed Stop or a Stop Program event has been configured, an additional run-time screen will show the scheduled stop time and all such screens will display a timer icon.

A.3.6: Scheduled Events

Each program can be set to automatically start its interval counters, pause or halt and then resume, initiate manual samples, or stop itself at scheduled times on specified days of the week. As discussed in Chapter 4.7 those **Program Events** are defined by a variable-length list of parameters, each of which has three associated values:

- the type of event (see table on next page),
- the days of the week on which the event will be executed, and
- the time of day on those days at which the event will be initiated.

Events do not have to be defined in the order they will execute, and can only be added or deleted from the end of the list.

Table A-1: Available Program Event Types

Start Program	The parent program will start automatically if it is ready when the scheduled time is reached on the next scheduled day.
Stop Program	The parent program will stop automatically if it is running when the scheduled time is reached on the next scheduled day. Unless the Auto Rerun option is enabled (Chapter 4.6.1), the program will have to be manually reset before it can be restarted.
Manual Sample	A manual sample will be drawn if the program is running when the scheduled time is reached on the next scheduled day. If a time or flow interval elapses while the manual sample is being drawn, an automatic sample will be drawn as soon as the manual sample cycle has been completed.
Pause Program	Sampling will be suspended if the program is running when the scheduled time is reached on the next scheduled day, but the time and flow interval counters will continue to run. Sampling can be resumed by a Resume Program event, or from the user interface panel. If one or more intervals elapse while the program is paused, only the first such sample will be drawn when the program is resumed.

Halt Program	The interval time and flow counters will be paused if the program is running when the scheduled time is reached on the next scheduled day. Those counters can be resumed (with the accumulated values they had at the time they were halted) by a Resume Program event, or from the user interface panel.
Resume Program	Interval sampling will resume if the program is paused or halted when the scheduled time is reached on the next scheduled day.
End List	Previous event is the last one on the list. Changing an event's type to End List deletes it and all high-numbered events.

A.3.7: Data Archiving

The log file contains the following info:

- each time one of its six sampling programs was started and stopped;
- each sample it has collected, including its weight, which bottle it was deposited into, and whether or not recycling was required to obtain the desired volume; and
- all operational exceptions, including:
 - power loss and restoration,
 - bottle-full sampling suspensions,
 - sequential turntable indexing errors, and
 - sample compartment temperature and deviations

These sample and exception records are separated into multiple log files. Each time a sampling program completes or is stopped, its log file is closed and a new one is opened. Exceptions that occur between sampling runs are thus logged into the following run's file. The controller will keep up to 50 such files, after which the oldest file will be deleted each time a new one is created. The newest file is accessed as log 1; the one recorded prior to log 1 is accessed as log 2, and so on.

Currently, those log files can only be:

- Reviewed onscreen when the menu system is not in use (Chapter 5.7)
- Deleted using the Administration Menu's Clear Archive option (Chapter 3.2.4).

Appendix B: Replacement Parts

Table B-1: Labels and Controller

	Part	Number	Additional Information
1	Field I/O Connector	WW002	7-pin CPC Panel Connector
	Protective Cover	WW005	
	Mating Cable Connector	WW001	Screw Terminations
2	Flow Inputs Connector	WW024	4-pin CPC Panel Connector
	Protective Cover	WW005	
	Mating Cable Connector	WW025	Screw Terminations
3	Controller, Complete	WW322	Specify Sampler Model Number
	Backup Battery	340503001	
	Face Plate	WW354	
	Face Plate Gasket	WW355	
	Logic Board	WW401	
	Power Board	WW320	
4	Label, 4-20Ma/Pulse Pinout	WW607	
5	Label, FLOAT/ALARM/RUN	WW608	
NOTE: 1. For current prices and quotations on parts, contact Teledyne Isco Service Department. 2. This list is subject to change without notice			

Table B-2: Exterior Parts

	Part	Number	Additional Information
1	Strainer, Low Flow	692903138	
	Strainer, Weighted	609004367	
	Strainer, CPVC	603704066	
2	Intake Tubing, 3/8-inch I.D.	029091603	sold by the foot—specify length
	Intake Tubing, 1/2-inch I.D.	029071406	sold by the foot—specify length
	Intake Kit, 3/8" (9mm)	602320008	includes 602703113 & 609004367
	Intake Kit, 1/2" (12mm)	602320004	includes 602320009 & 609004366
3	Door Latch	WW098	
4	PVC Bulkhead	WW426	
5	3/8" 90 Degree Nylon Elbow	WW127	Intake fitting (9mm)
	1/2" 90 Degree SST Elbow	WW748	Intake fitting (12mm)
NOTE: 1. For current prices and quotations on parts, contact Teledyne Isco Service Department. 2. This list is subject to change without notice			

Table B-3: Inside the Sampler

	Part	Number	Additional Information
1	Sequential Table Assembly	602320005	
2	Velocity-Limiter, Check Valve	WW019	
3	Velocity-Limiter, Bleed Valve	WW033	a.k.a. Pisco Valve
4	Turntable Connector Mating Cable Connector	WW171 WW172	6-pin CPC panel connector crimp-pin termination
5	Pinch Valve Assembly	WW373	
6	Temperature Sensor	WW757	
7	Sampler Chamber Assembly	WW618	
8	Load Cell Assembly	WW786	
NOTE: 1. For current prices and quotations on parts, contact Teledyne Isco Service Department. 2. This list is subject to change without notice			

Table B-4: Sequential Bottle Kit

	Part	Number	Additional Information
	500ml Bottle	WW218	Each
	Bottle Cap	299033400	Each
NOTE: 1. For current prices and quotations on parts, contact Teledyne Isco Service Department. 2. This list is subject to change without notice			

Table B-5: Composite Bottle Kits

	Part	Number	Additional Information
	1-bottle Configuration, Includes One 5-gallon (18.5-liter) bottle	682320025	HDPE, with lid and full bottle switch
	1-bottle Configuration, Includes One 3-gallon (11-liter) bottle	682320026	HDPE, with lid and full bottle switch
	1-bottle Configuration. Includes one 5.5-gallon (20.5-liter) bottle	299001306	HDPE, with lid
NOTE: 1. For current prices and quotations on parts, contact Teledyne Isco Service Department. 2. This list is subject to change without notice			

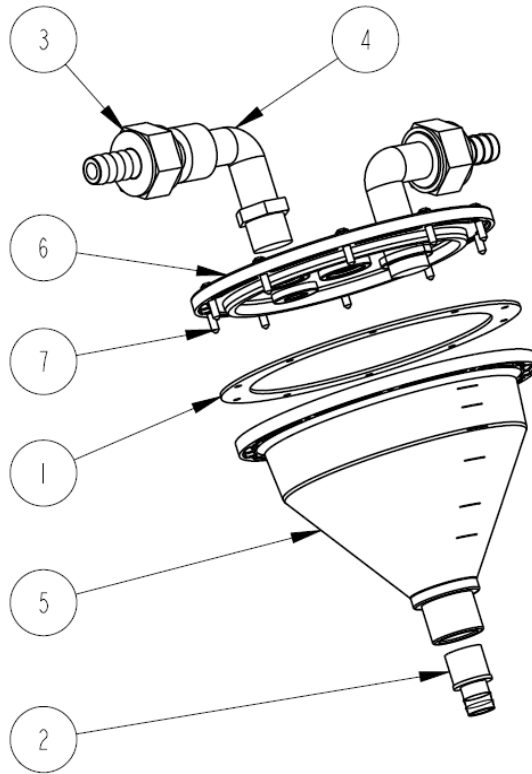

Figure B-6: Sample Chamber WW618 and Pinch Valve WW373

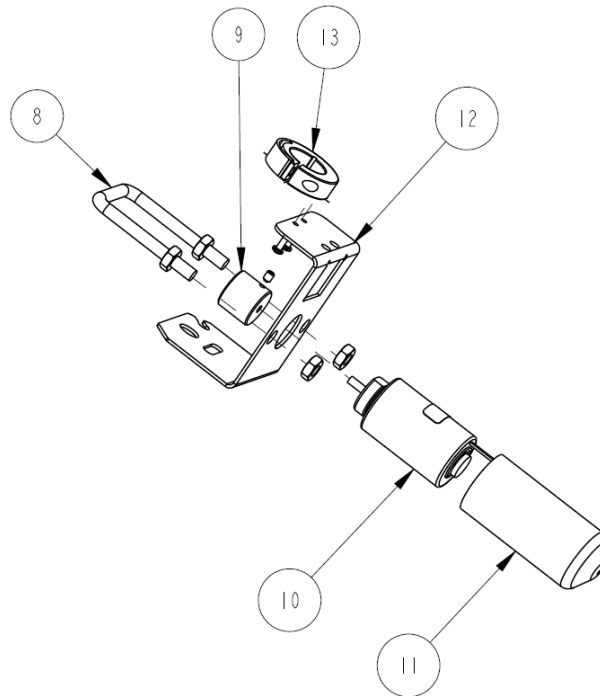

Table B-6: Sample Chamber WW618 and Pinch Valve WW373 Components

	Part	Number	Additional Information
1	Gasket	WW425	
2	Chamber Base Fitting	WW429	
3	1/2 Hose X Swivel Fitting	WW434	
4	1/2 MNPT x MGHT Elbow	WW435	
5	500mL Sample Chamber Base	WW458	
6	Sample Chamber Lid	WW459	
7	6-32 x 5/8 Pan head Screw	WW466	
8	Square Bend U-Bolt	WW186	
9	Plunger	WW190	
10	Pinch Valve	WW193	
11	3" Vinyl Cap	WW370	
12	Pinch Valve Bracket	WW802	
13	Set Collar	WW595	
NOTE: 1. For current prices and quotations on parts, contact Teledyne Isco Service Department. 2. This list is subject to change without notice			

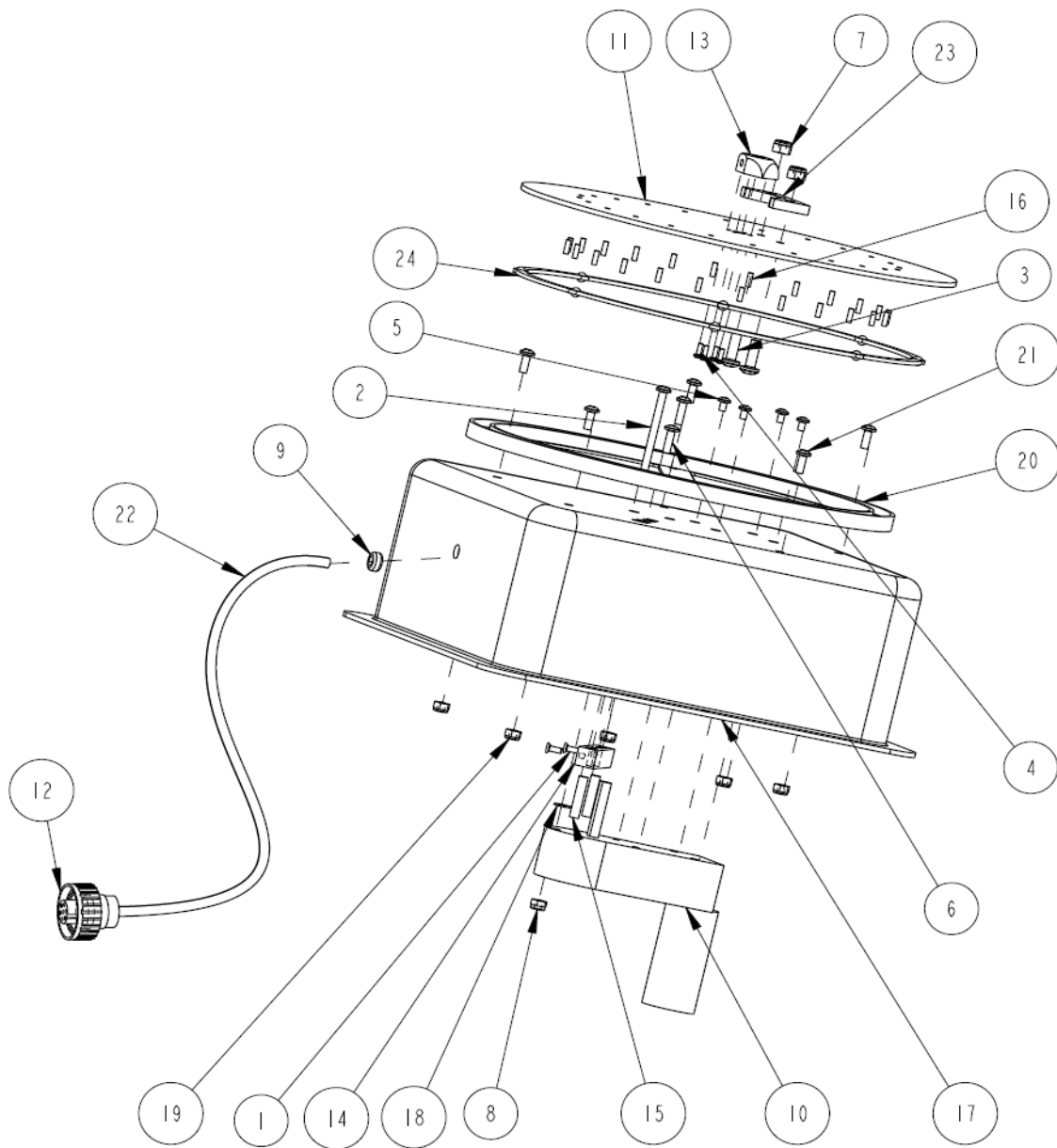

Figure B-7: Sequential Turntable Parts

Table B-7: Sequential Table Parts

ITEM	PART NUMBER	QTY	DESCRIPTION
1	231011406	2	SCR FLH 6-32X3/8
2	231014780	1	SCR PNH 10-32X2.5
3	231014912	2	SCR PNH 1/4-20X3/4
4	231514305	4	SCR PNH 4-40X5/16
5	231514504	4	SCR PNH 8-32X1/4
6	231514710	2	SCR PNH 10-32X5/8
7	232422520	2	NUT LK SST 1/4-20
8	232916101	1	NUT STOP 10-32
9	308-00133	1	GROMMET .25X.38 MTG ODX.062GRV
10	WW084	1	MOTOR, SEQ MODEL 440DC
11	WW163	1	SEQ TOP PLATE QL-41
12	WW172	1	CONN PLUG HSNQ MALE 7POS INLINE
13	WW206	1	SEQ DRIVE BLOCK S-55
14	WW209	1	SENSOR BLOCK
15	WW341	2	MAGNET SENSOR
16	WW342	24	MAGNET, 1/8" DIA X 3/8"LG
17	WW465	1	TABLE HOUSING
18	WW533	1	#10 FL WASHER 7/16 OD
19	WW534	5	NUT HEX S 10-24
20	WW535	1	BEARING RING TRACK
21	WW536	5	SCR PNH 10-24X1/2
22	WW713	1	CABLE, MULTI-CONDUCTOR
23	WW726	1	LOC BLOCK BOTTOM
24	WW535A	1	BEARING RING

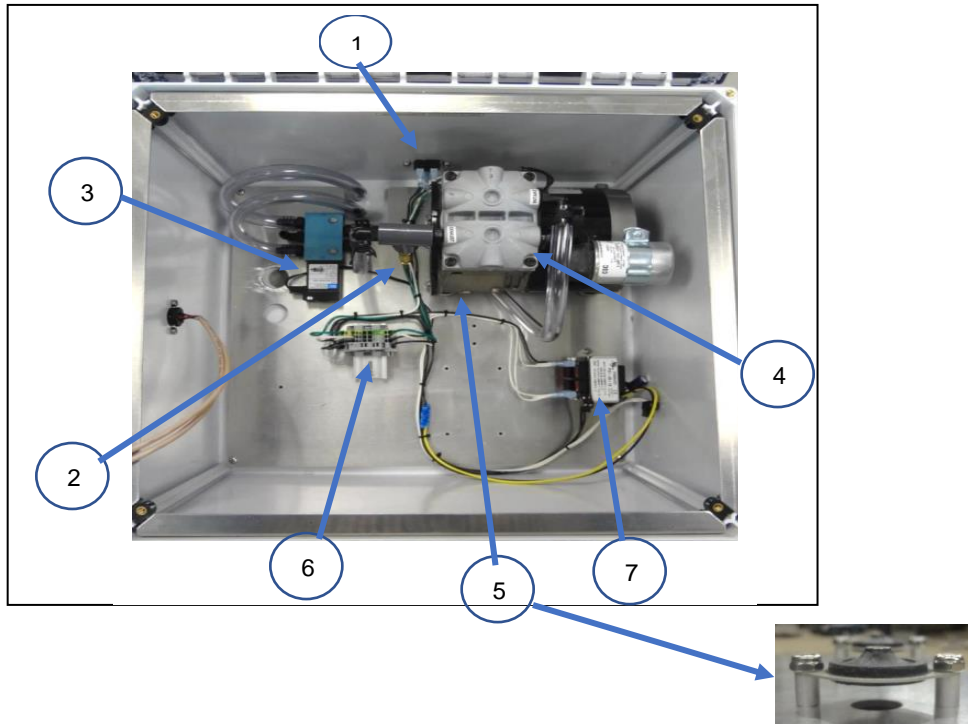

Figure and Table B-8: Electrical Components

	Part	Number	Additional Information
1	AC Power Connector	WW275	
2	Pressure Regulator, 20 psi	WW092	
3	Solenoid Valve, 4-Way	WW030	
4	115V Pump, (28ft) High Lift Piston Pump Service Kit 115V Pump,(23ft.)Standard Diaphragm Pump Service	WW102 WW298 WW103 WW391	115 VAC Piston Pump Rebuild piston pump kit 115 VAC Diaphragm Pump Rebuild diaphragm kit
5	Vacuum Pump Mounting Pads	WW131	4 required
6	3-position fuse block Fuse holder AC Fuse	WW364 WW362 WW326	10A/250V cartridge fuse
7	Transformer, Controller Power	WW300	Step-down from 120 to 240 VAC
	3-position terminal block 5-position terminal block 2-position terminal block	WW368 WW367 WW366	
NOTE: 1. For current prices and quotations on parts, contact Teledyne Isco Service Department. 2. This list is subject to change without notice			

