



# QCEC

*“Dependability Defined”*

## ***Explosion-Proof CVE-81*** ***Refrigerated Wastewater Sampler***



### **Operations and Maintenance Manual** **v2.0B October 19, 2015**

Part Number: 69-2303-611



**TELEDYNE ISCO**  
Everywhereyoulook™

4700 Superior Street • Lincoln, NE 68504  
(402) 464-0231 • (800) 228-4373  
[www.teledyneisco.com](http://www.teledyneisco.com) • [isco.info@teldeyne.com](mailto:isco.info@teldeyne.com)



August 2017

TO: Purchaser of QCEC Brand Products

FROM: Teledyne ISCO

We hope that you find this recent product purchase meets your needs. We wanted to update you that the QCEC product you purchased is now manufactured by Teledyne ISCO and is backed by Teledyne ISCO's commitment to quality products and exceptional customer service.

Teledyne Isco, a world leader in automatic water sampling and open channel flow monitoring products, acquired in late April 2017 the QCEC line of water & wastewater automatic samplers and flowmeters. With the addition of this sampling vacuum pump technology, we are able to offer a broader sampler product offering to meet customers' needs.

Teledyne Isco has been in business for over 50 years manufacturing a wide range of products for professionals working in water pollution monitoring and abatement, engineers and managers involved with wastewater process control, and scientists involved in field and laboratory work. We take pride in the fact that the products we produce are used by our customers to improve the quality of life on Earth.

We offer all our customers responsive, competent, and excellent service and support. Our customers are the most important part of our business, and we work tirelessly to ensure your complete satisfaction. Provided below are key contact information so that you can reach us at your convenience.

**Water & Wastewater Product Support:**

Telephone	(402) 853-5350
Toll Free (USA)	(866) 298-6174
Email	IscoEPS@teledyne.com

Teledyne ISCO  
4700 Superior Street  
PO Box 82531  
Lincoln, NE 68501

Telephone	(402) 464-0231
Fax	(402) 464-0318
Toll Free (USA)	(800) 228-4373
Email information request	<a href="mailto:iscoinfo@teledyne.com">iscoinfo@teledyne.com</a>
Website	<a href="http://www.teledyneisco.com">www.teledyneisco.com</a>



# Teledyne Isco Two Year Limited Factory Service Warranty\*

This warranty exclusively covers Teledyne Isco instruments, providing a two-year limited warranty covering parts and labor.

Any instrument that fails during the warranty period due to faulty parts or workmanship will be repaired at the factory at no charge to the customer. Teledyne Isco's exclusive liability is limited to repair or replacement of defective instruments. Teledyne Isco is not liable for consequential damages.

Teledyne Isco will pay surface transportation charges both ways within the 48 contiguous United States if the instrument proves to be defective within 30 days of shipment. Throughout the remainder of the warranty period, the customer will pay to return the instrument to Teledyne Isco, and Teledyne Isco will pay surface transportation to return the repaired instrument to the customer. Teledyne Isco will not pay air freight or customer's packing and crating charges. This warranty does not cover loss, damage, or defects resulting from transportation between the customer's facility and the repair facility.

The warranty for any instrument is the one in effect on date of shipment. The warranty period begins on the shipping date, unless Teledyne Isco agrees in writing to a different date.

Excluded from this warranty are normal wear; expendable items such as desiccant, pH sensors, charts, ribbon, lamps, tubing, and glassware; fittings and wetted parts of valves; check valves, pistons, piston seals, wash seals, cylinders, pulse damper, diaphragms, inlet lines and filter elements, and damage due to corrosion, misuse, accident, or lack of proper maintenance. This warranty does not cover products not sold under the Teledyne Isco trademark or for which any other warranty is specifically stated.

No item may be returned for warranty service without a return material authorization number issued by Teledyne Isco.

**This warranty is expressly in lieu of all other warranties and obligations and Teledyne Isco specifically disclaims any warranty of merchantability or fitness for a particular purpose.**

The warrantor is Teledyne Isco, 4700 Superior, Lincoln, NE 68504, U.S.A.

**\* This warranty applies to the USA and countries where Teledyne Isco does not have an authorized dealer. Customers in countries outside the USA, where Teledyne Isco has an authorized dealer, should contact their Teledyne Isco dealer for warranty service.**

Before returning any instrument for repair, please call, fax, or e-mail the Teledyne Isco Service Department for instructions. Many problems can often be diagnosed and corrected over the phone, or by e-mail, without returning the instrument to the factory.

Instruments needing factory repair should be packed carefully, and shipped to the attention of the service department. Small, non-fragile items can be sent by insured parcel post. **PLEASE BE SURE TO ENCLOSE A NOTE EXPLAINING THE PROBLEM.**

**Shipping Address:** Teledyne Isco - Attention Repair Service  
4700 Superior Street  
Lincoln, NE 68504 USA

**Mailing Address:** Teledyne Isco  
PO Box 82531  
Lincoln, NE 68501 USA

**Phone:** Repair service: (800) 775-2965 (lab instruments)  
(866) 298-6174 (samplers & flow meters)  
Sales & General Information: (800) 228-4373 (USA & Canada)

**Fax:** (402) 465-3001

**Email:** IscoService@teledyne.com



January 10, 2017 P/N 60-1002-041



## Table of Contents

Warranty .....	2
Table of Contents.....	3
List of Illustrations .....	3
List of Tables.....	3
Chapter 1 Introduction.....	4
1.1 Specifications .....	4
1.2 Physical Description.....	5
1.2.1 Sample Collection System.....	5
1.2.2 Sampling Control System.....	5
Chapter 2 Installation.....	6
2.1 Positioning Considerations.....	7
2.1.1 Hydrogen Sulfide Exposure.....	7
2.2 Electrical Connections.....	7
2.3 Sampling Intervals.....	8
2.4 Sampling Line Connection .....	9
2.5 Sample Size Adjustment.....	9
2.6 Intake Velocity Adjustment.....	9
Chapter 3 Operation.....	10
3.1 CVE-81 Sampling Cycle .....	10
Chapter 4 Maintenance.....	13
4.1 Cleaning the Sampler.....	13
4.1.1 Cleaning the Sample Chamber .....	13
4.2 Verifying and Adjusting the Temperature .....	13
4.3 Defrosting the Sample Chamber .....	14
4.4 Compressor/Vacuum Pump .....	14
Appendix A Replacement Parts.....	15

## List of Illustrations

Figure 3-1: CVE-81 Sampling Cycle.....	11
Figure 3-2: CVE-81 Timing Relay Circuit.....	12
Figure A-1: CVE-81 Pneumatic System Components and Connections .....	16
Figure A-2: Locations of Pneumatic System Components.....	17
Figure A-3: CVE-81 Sample Chamber Components.....	19
Figure A-4: CVE-81 Exterior Dimensions (in inches) .....	20

## List of Tables

Table A-1: Control System Parts.....	15
Table A-2: Intake Line Parts.....	15
Table A-3: Pneumatic System Parts.....	15
Table A-4: Sample Chamber Parts.....	18
Table A-5: Sample Containers and Bottles.....	18

## Chapter 1 Introduction

Explosion-Proof CVE-81 samplers collect wastewater samples at adjustable time or stream-flow intervals and deposit them into refrigerated composite-sample containers. Their vacuum pumps provide long-term consistent sampling with no need to frequently replace the internal tubes that render peristaltic pumps inconsistent, unreliable and costly to maintain.

If you have any questions or suggestions, feel free to call QCEC at 1-515-266-2268 and ask for wastewater sampling technical support.

### 1.1 Specifications

Hazardous Locations: Class I, Groups C and D  
Class II, Groups E, F, and G  
Class III

General Environment: Indoors or in protective enclosure, shielded from direct sunlight

Temperature, Ambient: 34 to 100 degrees F

Temperature, Interior: 4 to 10 degrees C

Electrical Service: 120VAC/single-phase/60 Hz (dedicated 15A circuit)

Minimum Vertical Lift: 2.0 feet (sampled stream at or below atmospheric pressure)

Maximum Vertical Lift: 22 feet

Maximum Horizontal: 25 feet

Minimum Sample Size: 50 mL

Maximum Sample Size: 500 mL

Flow Meter Input: 120VAC rated dry contact, or optional mA-to-pulses converter  
(4 mA=0 pulses/minute, 20 mA = 12 pulses/minute)

Sampling Frequency: 1 to 999 seconds, minutes, hours, or pulses



## 1.2 Physical Description

Each Explosion-Proof CVE-81 wastewater sampler consists of a refrigerated sample compartment with a sealed controls housing and vacuum/pressurization system mounted atop it—all of which are explosion-proof.

### 1.2.1 Sample Collection System

The sample collection system includes the following major components:

A clear plastic **sample chamber** with an adjustable wastewater inlet tube (whose projection into the chamber determines the sample size) and a pneumatic discharge-tube **pinch valve**.

A 120 VAC piston **air compressor/vacuum pump** with a redundant **check valve** that keeps water from being sucked into the pump.

Three explosion-proof **solenoid valves** that open and close the pinch valve and alternately evacuate and pressurize the sample chamber.

A pump discharge pressure regulator and intake velocity-limiting valve.

A 3/8 inch clear plastic **sampling tube** that extends to the sampled wastewater stream.

Each sample is collected by:

1. Blowing air through the chamber to clear the sampling tube.
2. Sucking waste water into the chamber until it is nearly full.
3. Blowing any excess water back out through the sampling tube.
4. Opening the discharge valve while continuing to blow air into the chamber, in order to drain the remaining waste water into the sample container.

The sample chamber, check valve and velocity-limiting valve are mounted in the refrigerated sample compartment, which also houses the composite-sample container. The explosion-proof pump, solenoid valve and pressure regulator are mounted on top of the sample compartment.

### 1.2.2 Sampling Control System

The CVE-81 sampling control system includes the following components mounted in sealed enclosures mounted on top of the sample compartment:

- a **manual button** that immediately triggers the sampling cycle;
- a Pulse/Off/Timer **mode selector** switch;
- an **interposing relay** (IR) that relays flow-meter pulses to the counter/timer when the Pulse mode is selected;
- a **counter/timer relay** (1T) that triggers the sampling cycle after an adjustable number of hours, minutes, seconds, or flow-meter pulses; and
- a motorized six-pole **cycle timer** (CT) that starts and stops the pump-motor, toggles the solenoid-valve that pressurizes and depressurizes the sample chamber, opens and closes the pinch valve, and resets the counter/timer relay.

*✎ If you configure your timer/counter relay to trigger the sampling sequence at timed intervals, the pulse input can be used to remotely enable and disable the unit.*

## Chapter 2 Installation

- ⚠ Upon initial receipt of your sampler, inspect its shipping container carefully for any sign of possible shipping damage. If such damage has occurred, notify QCEC and contact the carrier immediately to initiate a freight claim.
- ⚠ A qualified electrician must separately connect the control and refrigeration systems to a shared (or separate) 120VAC electrical branch circuit(s) via explosion-proof connections, conduits, and fittings.
- ⚠ The refrigeration thermostat is factory set to maintain your specified sample compartment temperature (usually 4 degrees C), so you should not need to verify or adjust it while installing the sampler.
- ⚠ Make sure the sampler has been sitting upright for at least 24 hours before powering up its refrigeration unit.

Each Explosion-Proof CVE-81 Sampler is meant to be used in a fixed location, with permanent electrical connections suitable to its hazardous-duty rating, and the far end of its sampling line fixed in the waste stream it is to sample. When you are ready to install yours:

1. Move it to its intended final location and remove it from its protective packaging and shipping pallet (which you should retain in case you ever need to ship your sampler back to QCEC or to any other location).
2. Set the sampler in its intended position [see section 2.1].
3. Level the sampler by adjusting its feet.
4. Make sure the unit's electrical service remotely turned off.
5. Connect the refrigeration unit to the unit's electrical service [see section 2.2].
6. Unscrew the top of the control enclosure.
7. Connect terminals 1 and 2 within the control enclosure to the unit's electrical service and (if desired) connect terminals 3 and 4 to a flow-meter signal [see section 2.2].
8. Set the timer/counter relay to the desired sampling interval in seconds, minutes, hours, or pulses [see section 2.3].
9. Close the control enclosure.
10. Install the wastewater sampling tube and intake fitting/strainer [see section 2.4].
11. With the mode selector switch in its Off position, remotely turn on the unit's 120 VAC electrical service.
12. Adjust the sample size by adjusting the intake tube [see section 2.5].
13. Adjust the intake velocity by adjusting the velocity-limiting valve [see section 2.6].
14. Make sure to leave the mode selector switch in its Off position.
15. Install the composite-sample container below the sample chamber discharge hose.
16. Close the sample-compartment door.

The unit is now ready for operation (see [Chapter 3](#)).

## 2.1 Positioning Considerations

Install your sampler in an indoor location or protective outdoor enclosure, with at least two (2) inches of clearance between its rear-mounted refrigeration condenser and the nearest wall (to allow adequate circulation of cooling air).

Place the unit as close as possible to the sample collection point. Its sampling chamber must be at least two (2) and no more than 22 feet above the unpressurized stream from which the samples will be drawn. If it is less than eight (8) feet above that stream, you will probably need to adjust the velocity-limiting valve to reduce the intake fluid velocity [see section 2.6].

If lift trucks and/or other moving equipment are frequently operated in the selected area, you might want to install protective barriers to keep them from running into the sampler.

### 2.1.1 Hydrogen Sulfide Exposure

Although the copper tubing in this sampler's refrigeration unit is coated to resist hydrogen sulfide (H<sub>2</sub>S) corrosion, high concentrations of that gas can still create pin-hole leaks after as little as a year or two of exposure. Therefore, you should select an installation location where the concentration of that gas is as low as possible. Because H<sub>2</sub>S is heavier than air, high locations should be favored.

*⚠ Refrigeration failures caused by excessive H<sub>2</sub>S exposure are not covered by QCEC's standard two-year warranty.*

## 2.2 Electrical Connections

*⚠ All electrical connections must be made by a qualified electrician and all cables must be enclosed within explosion-proof conduits and fittings.*

*⚡ The unit's electrical service must always be remotely turned off before exposing any of its electrical circuits to a potentially-explosive environment.*

The sampler's control and refrigeration systems must be separately connected to a shared (or to separate) 120VAC electrical branch circuit(s):

The sampling system is powered by 120VAC connected to terminals 1 and 2 within the sealed control enclosure, which has been drilled and tapped for a ½" NPT conduit fitting.

The refrigeration system is powered by 120VAC connected to terminals located behind its sealed back panel.

If you are going to draw samples at stream flow intervals, you must also use a shielded cable to connect a pulsing, dry-contact, flow meter relay (rated for at least a 120VAC signal) across terminals 3 and 4 within the control enclosure. You can route that signal's cable through the same conduit fitting as the 120VAC power cable, or drill and tap a second port.

If your flow meter does not provide a suitable dry-contact output, you must install a suitable interposing relay in an explosion-proof area or enclosure. For meters that provide only a 4-to-20 mA flow signal, QCEC offers an interposing relay that converts such a signal to pulses:

$$\text{pulses/minutes} = (C - 4\text{mA}) * 0.75$$

Thus, a 4 mA signal would yield no pulses, a 12 mA signal would yield 6 pulses per minute, and a 20 mA signal would generate 12 pulses per minute.

## 2.3 Sampling Intervals

The sampler can be set to automatically draw samples at regular time or flow intervals:

Flow intervals are configured by setting the counter/timer (1T) to the corresponding number of flow-meter pulses and operating the unit with its mode switch in the Pulse position. Setting it to sample after a single pulse would allow a remote PLC or SCADA system to initiate sampling by asserting the pulse input.

Time intervals are configured by setting 1T to the corresponding number of hours, minutes or seconds and operating the unit with its mode switch in the Timer position (for continuous timed sampling) or the Pulse position (for continuous sampling only while the Pulse input is asserted).

In either case, use the following procedure to change the duration of the selected interval:

1. Cut the power to the sampler and then open its main control enclosure.
2. The counter/timer relay has five thumbwheel switches:
  - a. The first (leftmost) of those switches must always be set to "A".
  - b. Set the last (rightmost) to:
    1. "H" to specify a timed interval in hours
    2. "M" to specify a timed interval in minutes
    3. "S" to specify a timed interval in seconds
    4. "co" to specify a pulse count interval
  - c. Set the middle three to specify the interval duration in the specified units (up to 999 hours, minutes, seconds or pulses).
3. Close the control enclosure and restore the sampler's electrical service.

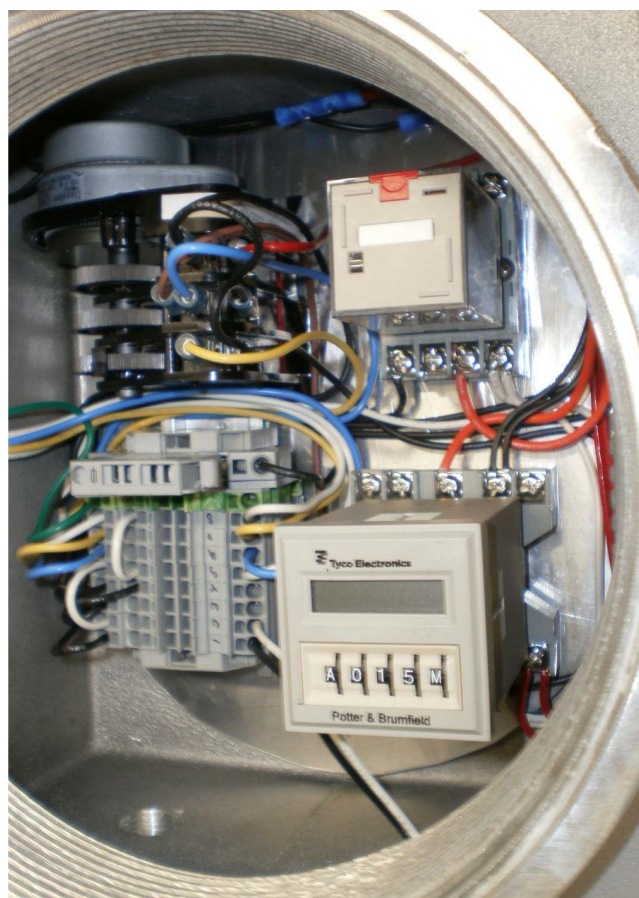

For example:

"A004H" would set the timer to trigger a sample every four hours.

"A480M" would set it to trigger a sample every 480 minutes (which would yield the same 8 hour interval as "A008H").

"A600S" would set it to trigger a sample every 600 seconds (which would yield the same 10 minute interval as "A010M").

"A050co" would set it to trigger one sample after every 50<sup>th</sup> flow-meter pulse.

## 2.4 Sampling Line Connection

Samples are drawn through a clear plastic tube that should be routed as directly as possible from the sample chamber to the wastewater stream:

1. Push that tube through the grommeted hole in the sample compartment's left side (which can be lubricated with liquid soap), then slide it over and clamp it onto the exposed end of the sample chamber's intake tube (WW064 in [Figure A-1](#), also shown below).
2. Route the other end of that tubing to the wastewater sampling point, sloping it downward as continuously as possible (so that it does not sag, kink or bend sharply).
3. After cutting that tubing to the needed length, attach a line strainer or weight fit to its far end and lower it into the sampled stream—preferably positioning it such that it remains in midstream rather than laying on the bottom.

## 2.5 Sample Size Adjustment

The Consistent Volume Extraction (CVE) system collects uniform samples by suctioning waste into the sample chamber until the water level is above the top of the intake tube, then blowing the excess back out. The size of those samples can thus be changed by adjusting how far the tube extends into the chamber (i.e., how far its top extends above the chamber base).

To adjust that height, repeat the following steps to obtain the desired sample size:

1. Loosen the compression fitting nut.
2. Slide the tube farther into or out of the chamber.
3. Retighten the compression fitting nut.
4. Turn the mode selector switch to Pulse.
5. Hold a graduated cylinder under the chamber's discharge tube, then initiate a manual sample by pressing the Manual pushbutton.
6. The sampling cycle takes 90 seconds, after which you can ascertain the sample size by checking the graduated cylinder.



## 2.6 Intake Velocity Adjustment

To achieve the most representative samples (distribution of suspended solids, etc.) the sampler's wastewater intake velocity should be as close as possible to the flow velocity of the sampled stream. If the intake velocity is too high, on the other hand, siphoning or overfilling of the sample chamber can result.

That intake velocity can be regulated by adjusted the vacuum bleed valve located at the base of the sample chamber's upper check valve:

If the intake velocity is too high, slowly open that valve until a smooth even flow of water into the chamber is achieved.

If the chamber fills too slowly to draw the desired volume of wastewater, slowly close that valve to increase the intake velocity.

## Chapter 3 Operation

Your Explosion Proof sampler requires little or no operator intervention—all you normally need to do is turn the mode selector switch to Off before the sample container overflows, replace that container with an empty one, and then turn the mode switch back to Timer or Pulse:

- If the counter/timer relay has been configured to count flow-meter pulses, sampling must be initiated by turning the mode switch to its Pulse position.  
If the counter has been set to draw a sample after each pulse, sampling can be triggered by a PLC or SCADA system relay connected to the pulse input.
- If that relay has been configured as a timer, sampling is usually enabled by turning the mode switch to its Timer position—which initiates sampling at regular intervals.  
However, if a remote enable switch has been connected to the pulse input, setting the mode switch to its Pulse position will cause samples to be drawn at timed intervals only while that remote switch is closed.

Pressing the Manual pushbutton will trigger the immediate collection of a sample and restart the selected (time or flow) interval counter.

### 3.1 CVE-81 Sampling Cycle

Figure 3-1 on the following page illustrates the 90-second CVE-81 sampling cycle:

1. The vacuum pump/compressor is started, which applies pressure to (and thus closes) the discharge pinch valve.
2. The sample chamber is pressurized (“prepurged”) to clear any accumulated water and debris from the sampling tube.
3. Vacuum is then applied to that chamber to draw in wastewater.
4. The sample chamber is then repressurized (“postpurged”) to expel any excess water and clear the entire sample intake tube.
5. The pinch valve is then opened (by depressurizing it) while still applying pressure to the sample chamber, thus gently expelling the remaining water to the sample container.

Those steps are sequenced by the positions of the cams on the six rotating wheels of the cycle timer (CT), which have the following functions (see Figure 3-2 on page 12):

1. Is closed for the duration of the sampling cycle, thus latching the sequencer’s trigger signal so the triggering pulse will cause it to rotate a full 360 degrees and then stop.
2. Turns the vacuum pump/compressor on and off.
3. Toggles solenoid S1 to apply either pressure or vacuum to the sample chamber.
4. Toggles solenoid S2 to direct pressurized air to either S1 or S3.
5. Toggles solenoid S3 to apply pressure to or release the pinch valve, thus closing or opening it.
6. Briefly opens at the onset of the cycle, thus resetting the counter/timer relay (1T) so consecutive samples are triggered the specified number of hours, minutes, seconds or pulses apart.

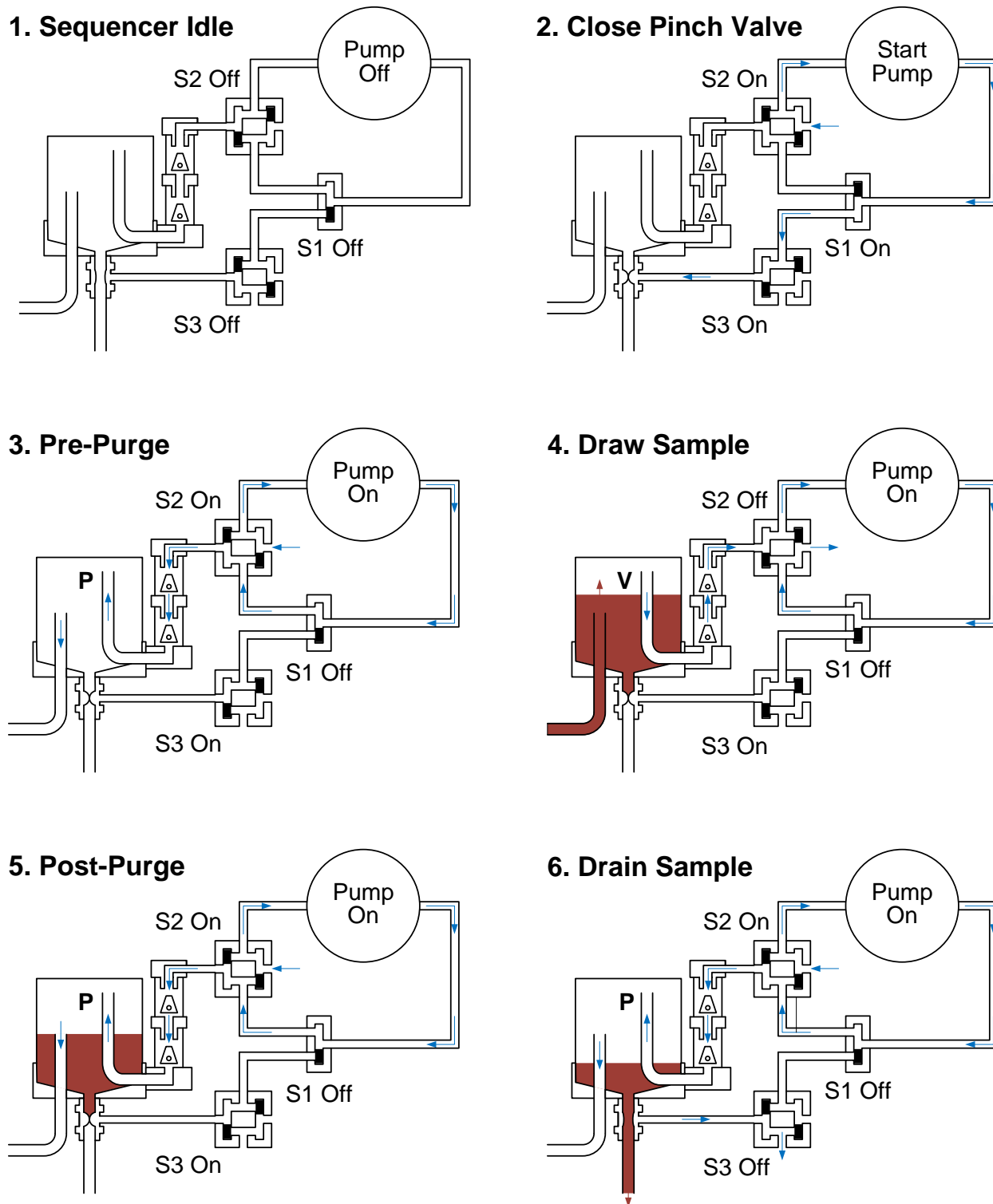

Figure 3-1: CVE-81 Sampling Cycle

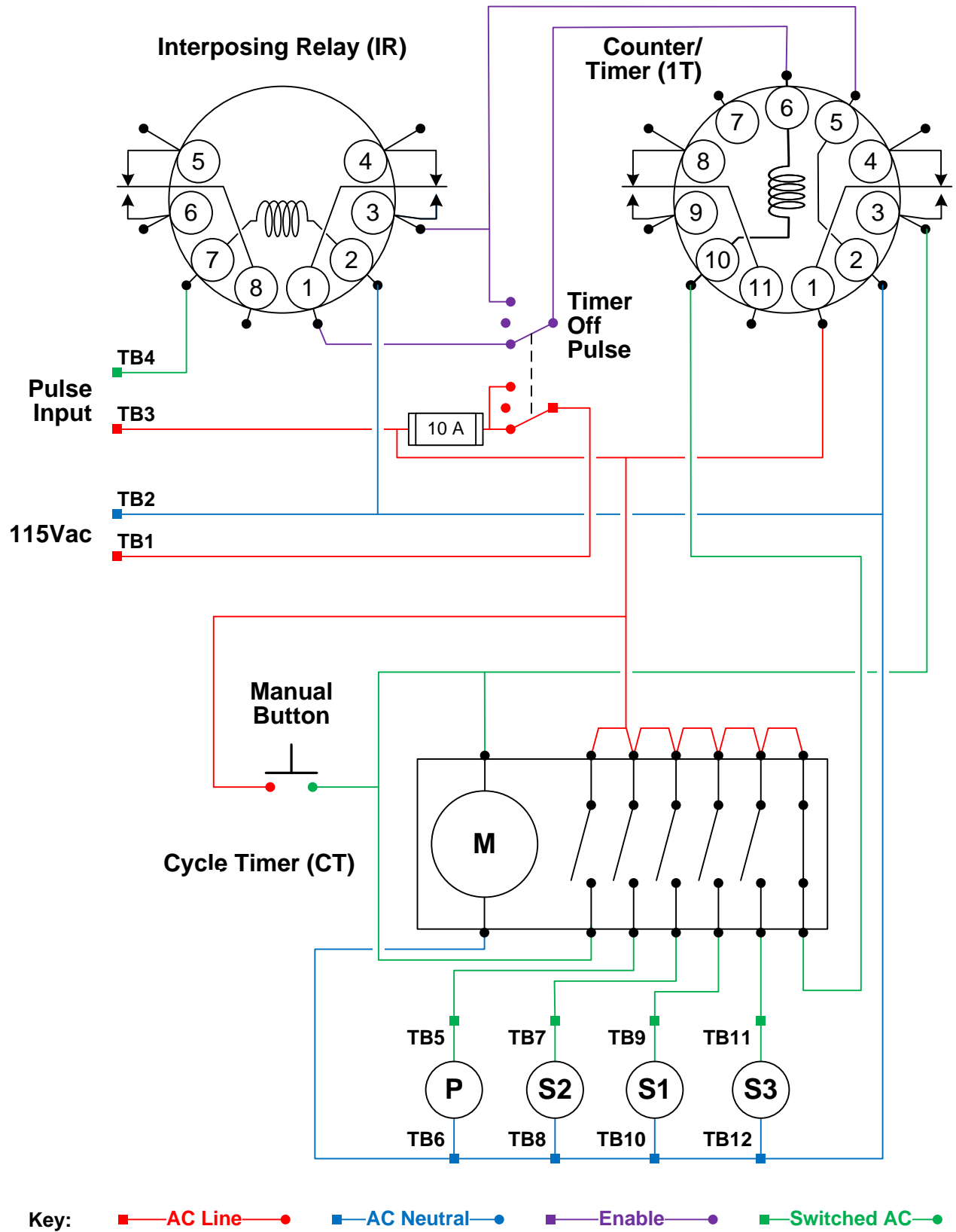

Figure 3-2: CVE-81 Timing Relay Circuit



## Chapter 4 Maintenance

Our Explosion-Proof Samplers are designed to be nearly maintenance free, but routine cleaning, defrosting and temperature verification are advisable, thermostat adjustment might occasionally be needed, and some parts might eventually wear out. Failed parts can be returned to the factory for repair or replacement, or you can order replacement parts using the numbers listed in Appendix A.

### 4.1 Cleaning the Sampler

In addition to immediately cleaning up any spilled wastewater, you should periodically clean the interior and exterior of the sampler. This should include blowing any accumulation of dust off the exposed refrigeration coils behind the lower portion of the sampler.

If any wastewater has been spilled within the sample compartment, it should be washed out with soapy water, then rinsed and dried.

The intake line can be cleaned by drawing several samples from a bucket of warm, soapy water, followed by several more drawn from a bucket of warm rinse water. Replace the tubing if that process fails to remove all significant fouling.

#### 4.1.1 Cleaning the Sample Chamber

1. Remove the 2 bolts that secure the mounting bracket to the sampler wall
2. Remove the sample chamber body from the unit by unscrewing lid
3. Remove the hose clamps that secure the float chamber hose and remove float cones
4. Remove the volume adjustment sleeve. To remove the sleeve, slip the 90 degree end off of the straight section of the sleeve. These two parts are coupled by means of 3/8 " ID tubing. Slowly work the bend back and forth while pulling out the adjustment knob.
5. The chamber is now ready for cleaning. It is best to soak the parts in warm soapy water for a few minutes and scrub with a brush.
6. If O-ring replacement is required, simply remove the float chamber hose clamps, volume chamber body and remove both volume adjustment sleeve O-rings, install new O-rings taking care that the new O-rings are seated in the groves properly.
7. To reassemble the chamber, simply reverse the above steps.

### 4.2 Verifying and Adjusting the Temperature

Although the refrigeration unit is factory set and verified to maintain your desired sample compartment temperature, its performance can drift over time. So a calibrated refrigeration thermometer should periodically be used to determine how close the sample compartment is being kept to the desired temperature.

The temperature setting is changed by slightly rotating a dial within the sample compartment, allowing the unit to run for at least 24 hours with the calibrated thermometer in place, and then checking the resulting temperature. Continue adjusting that dial every day or so, if needed, until the desired temperature is achieved.

### 4.3 Defrosting the Sample Chamber

Depending on how often your sampler is opened and your ambient temperature and humidity, the accumulation of frost on the evaporator plate at the rear of its sample compartment may occasionally need to be removed.

If the thickness of the frost and ice layer should exceed ½", you should defrost the unit by turning the thermostat off (first note its position) and leaving the door open until all frost has melted. Then dry the unit thoroughly, return the refrigeration dial to its original position, and close the door.

You might want to place a pan inside the unit to catch the resulting water, or place towels there to soak it up. You might also want to accelerate the melting using a hair dryer or similar device. You must not attempt to scrape off the frost and ice!

- ⊘ *DO NOT chip the frost off the evaporator plate, as doing so could puncture or otherwise damage the refrigerant channels.*

### 4.4 Compressor/Vacuum Pump

Each Explosion-Proof CVE-81 sampler is equipped with an explosion-proof, continuous-duty, permanently-lubricated, piston air compressor/vacuum pump that ***needs no routine maintenance.*** In particular, and unlike the inconsistent, unreliable and costly to maintain peristaltic pumps used in competing samplers, it does not have a flexible internal tube that frequently wears out and needs to be replaced.

However, if your pump's performance ever declines unacceptably, replacement pumps and service kits (including instructions) can be obtained from QCEC.

## Appendix A Replacement Parts

Table A-1: Control System Parts

Part	Part Number	Additional Information
AC Fuse	WW326	fast-acting, 10A/250 V cartridge fuse
Cycle Timer (CT)	WW-291	6-drum motorized sequencer
Interposing Relay (IR) 8-Pin Base	MKS2PIAC120 SR2P06	8-pin, 120V, DPDT
Manual Control Station	WW419	NO, momentary, explosion-proof
Mode Selector Switch	WW229	DPDT, Center-Off toggle switch
Timer/Counter Relay (1T) 11-Pin Base	CNT-35-96 SR3P06	0-999 seconds/minutes/hours/pulses

Table A-2: Intake Line Parts

Part	Part Number	Additional Information
Intake Strainer, PVC & Stainless	WW189	
Intake Strainer, Stainless Steel	WW181	
Intake Tubing, 3/8-inch I.D.	WW043	sold by the foot—specify length

Table A-3: Pneumatic System Parts

Part	Part Number	Additional Information
Flow Adjustment Valve	WW166	
Pinch Valve, Pneumatic	WW294	
Pressure Bleed Valve	WW033	
Pressure Regulator, 20 psi	WW092	
Pump, Vacuum/Compression	WW219	
Pump Motor	WW418	
Pump Coupling Half, 5/8"	WW234	
Pump Coupling Half, 1/2"	WW235	
Pump Coupling Flex Insert	WW236	
Pump Coupling Guard	WW251	
Solenoid Valve, 3-Way	WW248	S1
Solenoid Valves, 4-Way	WW232	S2 and S3 (2 required)

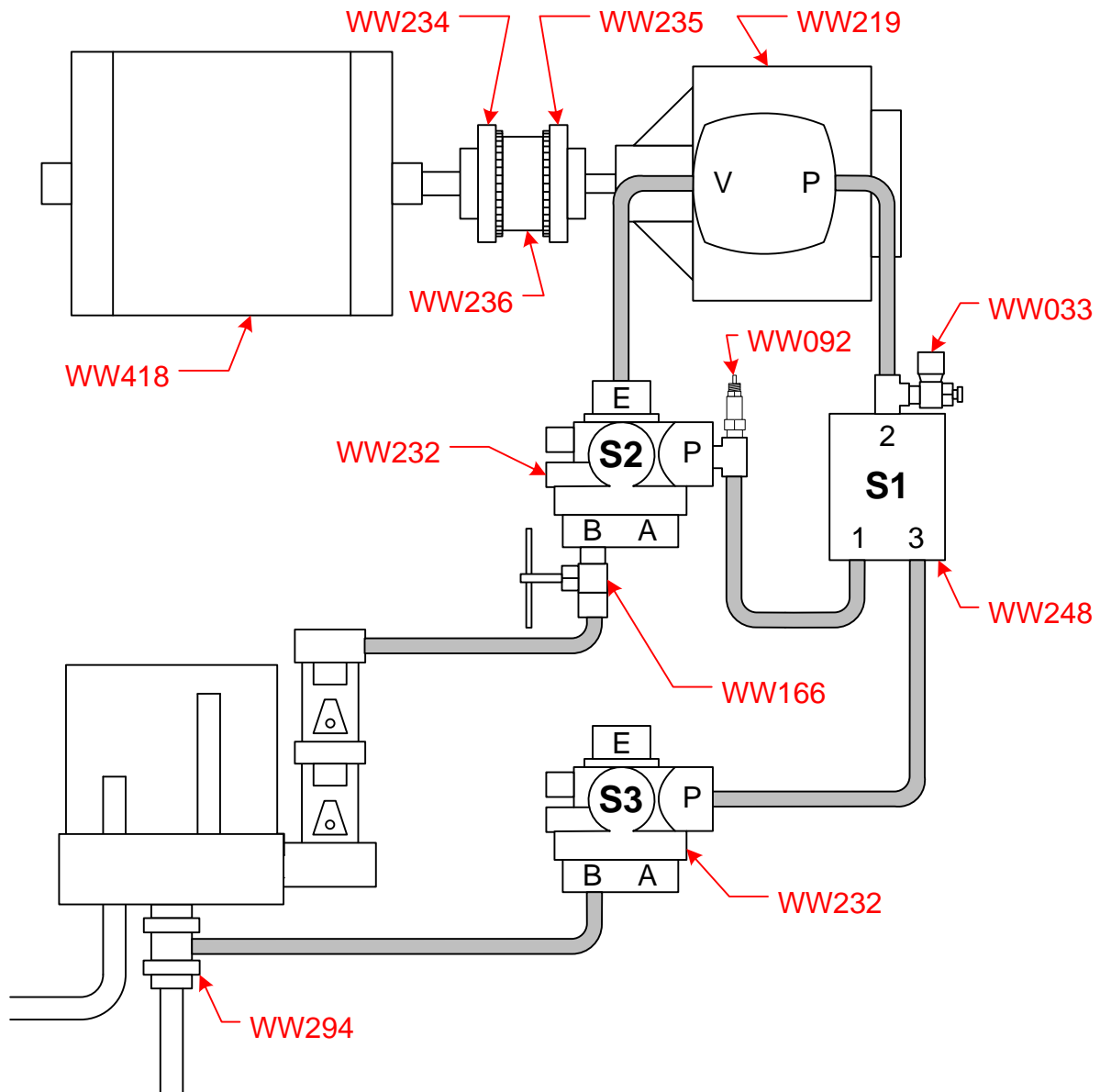

Figure A-1: CVE-81 Pneumatic System Components and Connections

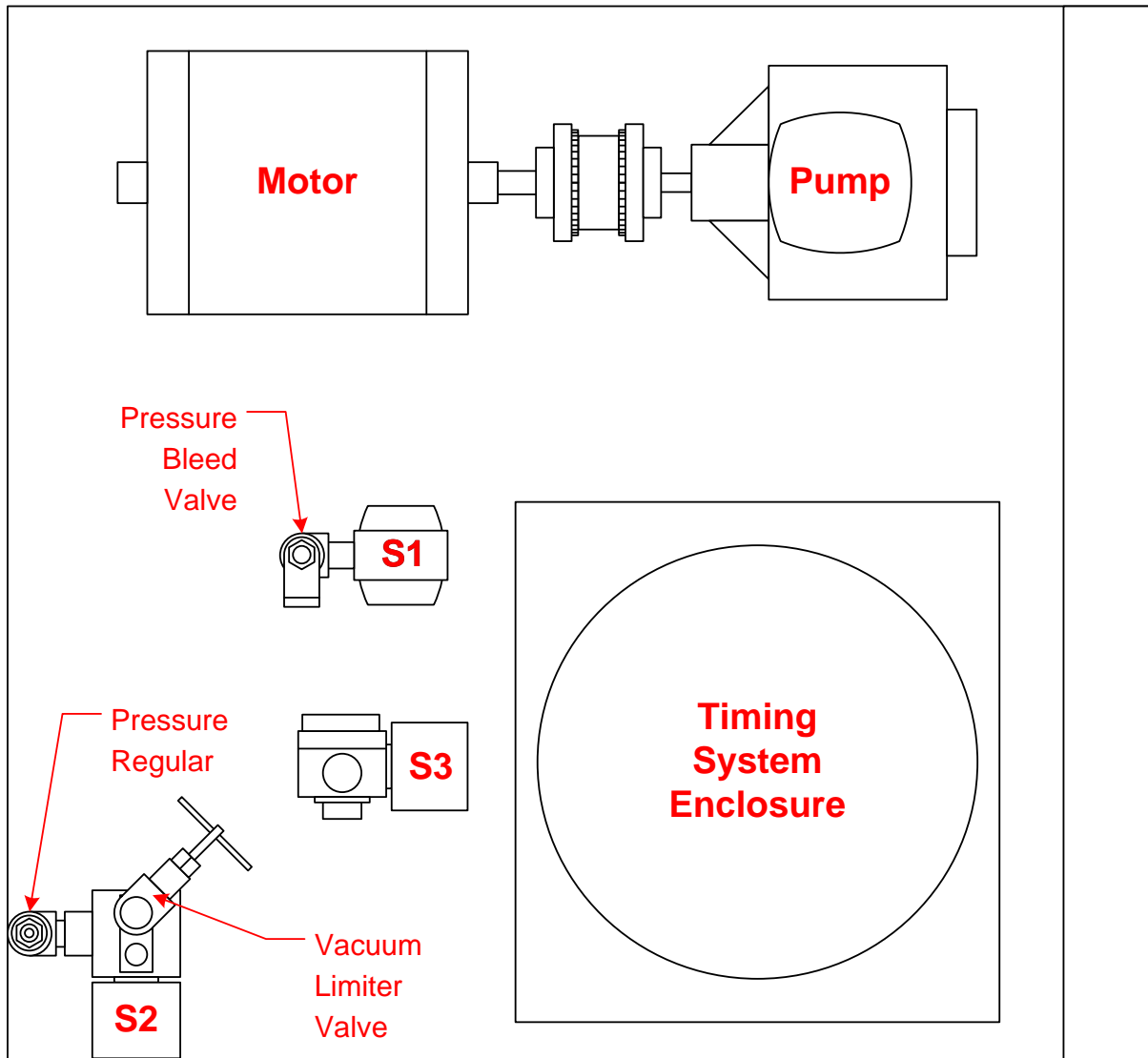

Figure A-2: Locations of Pneumatic System Components

Table A-4: Sample Chamber Parts

Part	Part Number	Additional Information
Adjustment Sleeve	WW066	
Adj. Sleeve O-Ring	WW014	2 required
Adj. Sleeve Retainer	WW018	
Center Block	WW022	between float chambers
Chamber Base	WW012	
Chamber Base O-Ring	WW013	
Chamber Body	WW048	
Discharge Fitting	WW108	
Discharge Hose	WW050	cut to length after installing
Float Chamber Clamp	WW036	4 required
Float Chamber Cone	WW032	2 required
Float Chamber	WW065	2 required
Float Chamber O-Ring	WW017	2 required
Intake Fitting	WW062	
Intake Tube	WW064	
Pinch Valve, Pneumatic	WW294	
Radius Block	WW020	
Radius Block Gasket	WW021	
Top Block	WW023	
Vacuum Fitting	WW116	
Velocity-Limiter, Bleed Valve	WW033	a.k.a. Pisco Valve
Velocity-Limiter, Check Valve	WW019	

Table A-5: Sample Containers and Bottles

Part	Part Number	Additional Information
Bottle, 10 L (2.6 Gal.) Glass	WW220	includes cap
Bottle, 10 L (2.6 Gal.) LDPE	WW201	includes cap
Bottle, 20 L (5.3 Gal) LDPE	WW202	includes cap
Container, 3.0 Gallon HDPE	WW179	
Lid	WW194	
Container, 5.0 Gallon HDPE	WW177	
Lid	WW178	

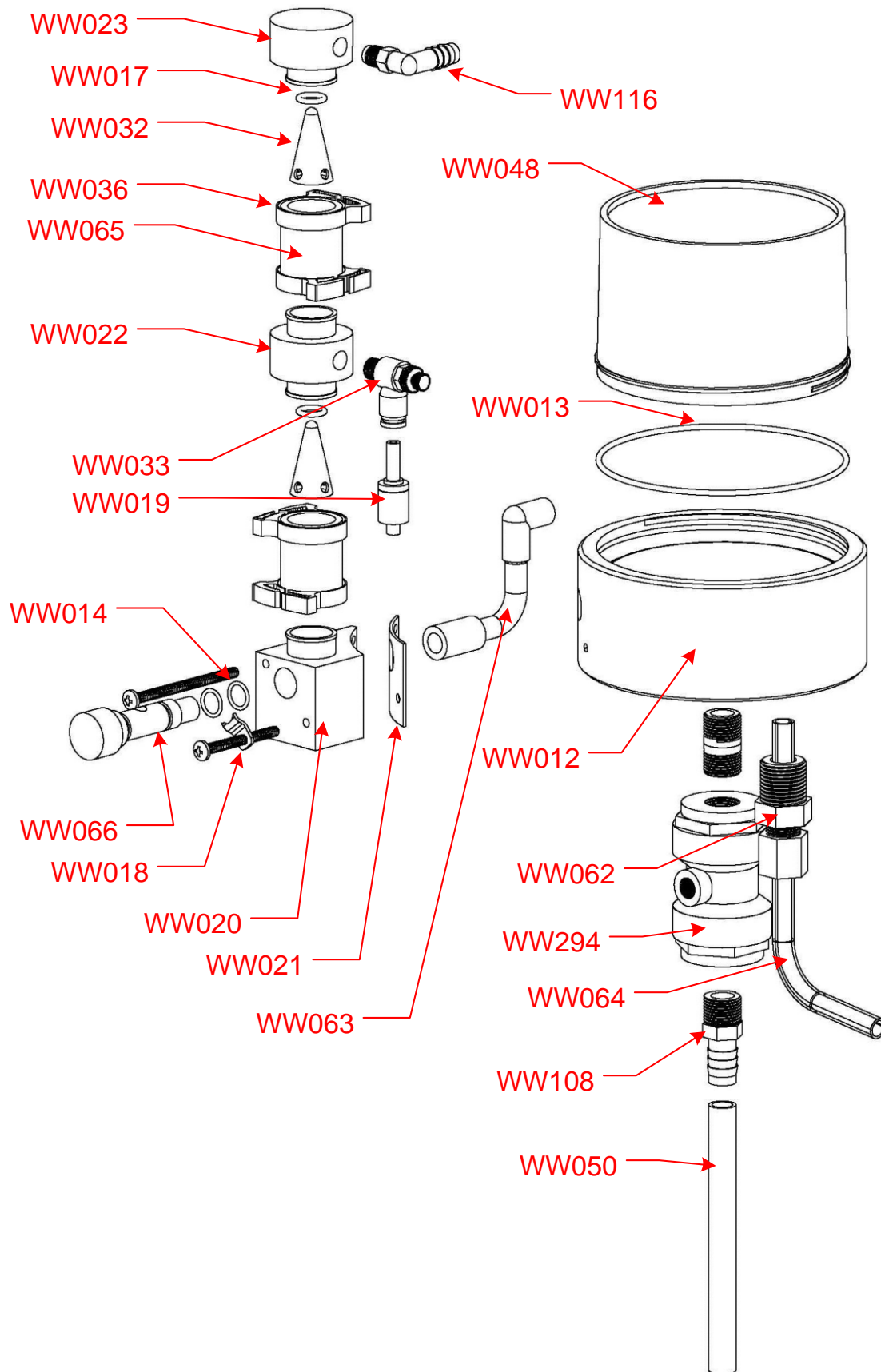

Figure A-3: CVE-81 Sample Chamber Components

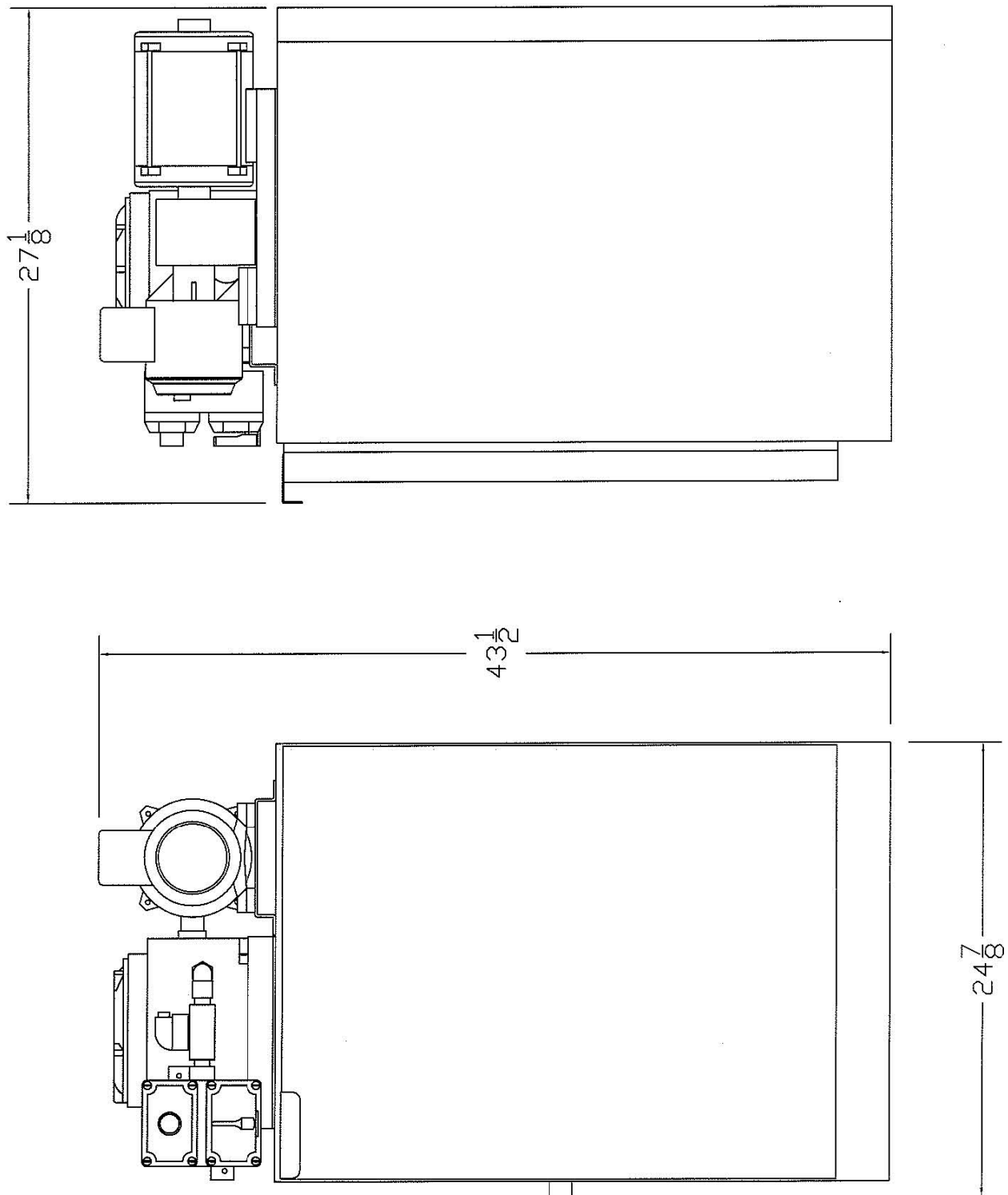

Figure A-4: CVE-81 Exterior Dimensions (in inches)