

4700 Refrigerated Sampler

Installation and Operation Guide



Part #69-4703-086 of Assembly #60-4704-051
Copyright © 2006. All rights reserved, Teledyne Isco
Revision W, November 2015

Foreword

This instruction manual is designed to help you gain a thorough understanding of the operation of the equipment. Teledyne Isco recommends that you read this manual completely before placing the equipment in service.

Although Teledyne Isco designs reliability into all equipment, there is always the possibility of a malfunction. This manual may help in diagnosing and repairing the malfunction.

If a problem persists, call or e-mail Teledyne Isco technical support for assistance. Simple difficulties can often be diagnosed over the phone. For faster service, please have your serial number ready.

If it is necessary to return the equipment to the factory for service, please follow the shipping instructions provided by technical support, including the use of the **Return Merchandise Authorization (RMA)** specified. **Be sure to include a note describing the malfunction.** This will aid in the prompt repair and return of the equipment.

Teledyne Isco welcomes suggestions that would improve the information presented in this manual or enhance the operation of the equipment itself.

Teledyne Isco is continually improving its products and reserves the right to change product specifications, replacement parts, schematics, and instructions without notice.

Contact Information

Customer Service

Phone: (800) 228-4373 (USA, Canada, Mexico)
(402) 464-0231 (Outside North America)
Fax: (402) 465-3022
Email: IscoCSR@teledyne.com

Technical Support

Phone: Toll Free (866) 298-6174 (Samplers, Flow Meters and Multi-parameter Probes)
Toll Free (800) 775-2965 (Syringe Pumps and Liquid Chromatography)
Email: IscoService@teledyne.com
or
Iscoeps@teledyne.com

Return equipment to: 4700 Superior Street, Lincoln, NE 68504-1398

Other Correspondence

Mail to: P.O. Box 82531, Lincoln, NE 68501-2531
Email: IscoInfo@teledyne.com

Safety Information

The Isco 4700 Refrigerated Sampler is a “definite purpose” device, intended for use only with compatible Isco equipment. Except as described in this manual, do not use this product with any other manufacturers’ equipment, or for any other purpose. Use for any purpose not described in this manual could cause personal injury or property damage.

Electrical Requirements

The sampler requires 100V/50Hz, 115V/60 Hz, or 230V/50Hz AC power. Refer to the nameplate and ratings label inside the refrigerator compartment. The power input is through the mains power cord at the back of the sampler. The sampler is protected by an internal thermal cut-out. Additionally, the sampler controller circuitry is protected by an internal 5.0 ampere PTC (Positive Temperature Coefficient) device.

  **WARNING**

Electrocution hazard. Never manipulate electrical switches or power connections with wet hands or when your feet are in contact with water.

  **WARNING**

AC electrical power must meet the applicable electrical code requirements for your installation and must be provided with an earth ground connection. If necessary, consult with a certified electrician to ensure that AC power is provided in accordance with the local electrical code.

The AC power cord of this device is equipped with a three-prong grounding plug designed to mate with a grounded power outlet. Grounding minimizes the possibility of electrical shock.

It is the user’s responsibility to ensure that the AC power source is properly grounded. If in doubt, have the outlet checked by a qualified electrician.

If the available AC power outlet only accepts two prongs, or if it is determined that the outlet is improperly grounded, the outlet must be replaced by a qualified electrician before attempting to power this device.

  **WARNING**

Never modify the AC power cord or use a three-prong to two-prong adapter.

  **WARNING**

If this device’s power cord is frayed or otherwise damaged, discontinue its use immediately. The AC power cord is not user-serviceable and must be returned to the factory for repair or replacement.

General Warnings

Before installing, operating, or maintaining this equipment, it is imperative that all hazards and preventive measures are fully understood. While specific hazards may vary according to location and application, take heed in the following general warnings:

 **WARNING**

This instrument has not been certified for use in “hazardous locations” as defined by the National Electrical Code.

 **WARNING**

Avoid hazardous practices! If you use this instrument in any way not specified in this manual, the protection provided by the instrument may be impaired; this will increase your risk of injury.

Additional safety information can be found in Appendix B.

Hazard Severity Levels

This manual applies *Hazard Severity Levels* to the safety alerts. These three levels are described in the sample alerts below.

 **CAUTION**

Cautions identify a potential hazard, which if not avoided, may result in minor or moderate injury. This category can also warn you of unsafe practices, or conditions that may cause property damage.

 **WARNING**

















Warnings identify a potentially hazardous condition, which if not avoided, could result in death or serious injury.

 **DANGER**

DANGER – limited to the most extreme situations to identify an imminent hazard, which if not avoided, will result in death or serious injury.

Hazard Symbols

The equipment and this manual use symbols used to warn of hazards. The symbols are explained below.

Hazard Symbols	
Warnings and Cautions	
	The exclamation point within the triangle is a warning sign alerting you of important instructions in the instrument's technical reference manual.
	The lightning flash and arrowhead within the triangle is a warning sign alerting you of "dangerous voltage" inside the product.
 	Pinch point. These symbols warn you that your fingers or hands will be seriously injured if you place them between the moving parts of the mechanism near these symbols.
Symboles de sécurité	
	Ce symbole signale l'existence d'instructions importantes relatives au produit dans ce manuel.
	Ce symbole signale la présence d'un danger d'électocution.
 	Risque de pincement. Ces symboles vous avertit que les mains ou les doigts seront blessés sérieusement si vous les mettez entre les éléments en mouvement du mécanisme près de ces symboles
Warnungen und Vorsichtshinweise	
	Das Ausrufezeichen in Dreieck ist ein Warnzeichen, das Sie darauf aufmerksam macht, daß wichtige Anleitungen zu diesem Handbuch gehören.
	Der gepfeilte Blitz im Dreieck ist ein Warnzeichen, das Sei vor "gefährlichen Spannungen" im Inneren des Produkts warnt.
 	Vorsicht Quetschgefahr! Dieses Symbol warnt vor einer unmittelbar drohenden Verletzungsgefahr für Finger und Hände, wenn diese zwischen die beweglichen Teile des gekennzeichneten Gerätes geraten.
Advertencias y Precauciones	
	Esta señal le advierte sobre la importancia de las instrucciones del manual que acompañan a este producto.
	Esta señal alerta sobre la presencia de alto voltaje en el interior del producto.
 	Punto del machacamiento. Sus dedos o manos seriusly serán dañados si usted los coloca entre las piezas móviles cerca de estos símbolos.

Isco 4700 Refrigerated Sampler

Table of Contents

Section 1 Introduction

1.1 Sampler Overview	1-1
1.2 Features	1-2
1.3 Specifications	1-4

Section 2 Installation

2.1 Unpacking the Sampler	2-1
2.2 4700 Sampler Installation Overview	2-1
2.3 Positioning the Sampler	2-1
2.4 Installing a Bottle Kit	2-4
2.4.1 Installing the Distributor Arm and Discharge Tube	2-5
2.4.2 24 Bottles	2-6
2.4.3 4 Bottles	2-8
2.4.4 2 Bottles	2-8
2.4.5 1 Bottle	2-9
2.5 Attaching the Suction Line	2-10
2.5.1 Vinyl Suction Line	2-11
2.5.2 FEP-lined Suction Line	2-11
2.6 Attaching a Strainer	2-12
2.6.1 Alternative to Strainers	2-13
2.6.2 Maximum Unanchored Depth	2-13
2.7 Routing the Suction Line and Strainer	2-13
2.8 Connecting the Sampler to External Devices	2-14
2.8.1 Standard Isco Instrument Connections	2-14
2.8.2 Other Device Connections	2-15
2.9 Connecting Power	2-17
2.9.1 Backup Power	2-17
2.10 Configuring and Programming the Sampler	2-18
2.11 Locking the Sampler	2-18

Section 3 Programming

3.1 Control Panel Description	3-1
3.2 Getting Started	3-2
3.3 Configuring the Sampler	3-3
3.3.1 Set Clock	3-3
3.3.2 Bottles and Sizes-Standard	3-4
3.3.3 Bottles and Sizes-Custom	3-4
3.3.4 Suction Line	3-5
3.3.5 Liquid Detector	3-6
3.3.6 Flow Mode Sampling	3-6
3.3.7 Enable Pin	3-7
3.3.8 Refrigeration	3-7
3.3.9 Output Pins	3-8
3.3.10 Tubing Life	3-9
3.3.11 Program Lock	3-10
3.3.12 Language	3-11

3.3.13	System IDs	3-11
3.3.14	Run Diagnostics	3-11
3.3.15	Exit Configuration	3-11
3.4	Sampling Program Overview	3-12
3.5	Programming Steps	3-15
3.5.1	Pacing	3-15
3.5.2	Sample Every	
	__ Hours, __ Minutes	3-15
3.5.3	Sample Every	
	__ Pulses	3-15
3.5.4	__ Bottles per Sample Event	3-18
3.5.5	Switch on Time or Number of Samples	3-18
3.5.6	Switch Sets Every	
	__ Hours, __ Minutes	3-18
3.5.7	First Switch Time	3-18
3.5.8	__ Samples per Bottle	3-19
3.5.9	Run Continuously?	3-19
3.5.10	Enter Sample Volume Use Defined Sample	3-19
3.5.11	Volumes Dependent on Flow?	3-20
3.5.12	Sample Volume __ ml	3-20
3.5.13	Flow Pulses,	
	Analog Input	3-20
3.5.14	10 ml for Every	
	__ Pulses	3-20
3.5.15	Sample Volume at	
	20 mA: __ ml	3-21
3.5.16	__ Composite Samples	3-21
3.5.17	Suction Head	3-21
3.5.18	No Delay to Start	
	Set Start Time	3-22
3.5.19	First Sample At:	3-22
3.5.20	Start Flow Count At:	3-22
3.5.21	Select Days:	3-22
3.5.22	First Valid Day	3-22
3.5.23	Maximum Run Time	
	__ Hours	3-22
3.6	Programming Examples	3-22

Section 4 Operation

4.1	Start a Sampler Program	4-1
4.1.1	Start Time Delay	4-1
4.1.2	The Run State	4-2
4.1.3	Completed Program	4-2
4.2	Pause or Stop a Running Program	4-3
4.3	Post Sampling Activities	4-3
4.3.1	View the Log	4-3
4.3.2	Retrieve the Temperature Log	4-5
4.3.3	Sampling Reports	4-7
4.3.4	Remove Sample Bottles	4-7
4.4	Grab Samples	4-8
4.5	Calibrate Sample Volumes	4-8
4.6	Operate the Pump Manually	4-9

Section 5 Maintenance

5.1	Periodic Maintenance Checklist	5-1
5.1.1	Pump Inspection	5-1

5.1.2	Pump Tube Replacement	5-3
5.1.3	Cleaning the Pump Rollers	5-5
5.1.4	Cleaning the Pump Housing	5-5
5.1.5	Cleaning or Replacing Wetted Parts	5-5
5.1.6	Sampler Cleaning Guidelines	5-6
5.2	Sampler Diagnostics	5-6
5.2.1	Test 'RAM'	5-7
5.2.2	Test 'ROM'	5-7
5.2.3	Test Display	5-8
5.2.4	Test Keypad	5-8
5.2.5	Test Pump	5-8
5.2.6	Test Distributor	5-9
5.2.7	Test Flow Meter Port	5-10
5.2.8	Refrig Temperature	5-10
5.2.9	PCB Temperature	5-10
5.2.10	Input Voltage	5-11
5.2.11	Battery Voltage	5-11
5.2.12	Loaded Battery Volts	5-11
5.2.13	Analog Input	5-12
5.3	Temperature Verification	5-13

Appendix A Replacement Parts List

A.1	Sampler/Refrigerator Replacement Parts	A-2
A.2	Bottle Configuration Replacement Parts	A-32

Appendix B General Safety Procedures

B.1	Hazards	B-1
B.2	Planning	B-2
B.3	Adverse Atmospheres	B-2
B.4	Entering Manholes	B-2
B.4.1	Traffic Protection	B-3
B.4.2	Removing the Covers	B-3
B.4.3	Other Precautions	B-3
B.4.4	Emergencies	B-4
B.4.5	Field Equipment	B-4
B.5	Lethal Atmospheres in Sewers	B-4

List of Figures

1-1	4700 Sampler features	1-2
2-1	Minimum space requirements	2-3
2-2	Installing the distributor arm (A) and discharge tube (B)	2-5
2-3	Insert the keyed end first so that it faces the back of the refrigerated compartment	2-7
2-4	The 24-bottle rack is held in place by a latch on the left side	2-7
2-5	Installing the standard locating base	2-8
2-6	One 20 liter bottle configuration with discharge tube through the bottle cap	2-10
2-7	Attaching the suction line to the pump tubing	2-11
2-8	Connecting FEP-lined suction line (A) to pump tube (B)	2-11
2-9	Strainers	2-12
2-10	External device connection at rear of sampler	2-14
2-11	4700 Sampler to Isco flow meter cable	2-15
2-12	4700 Sampler unterminated connect cable	2-15
2-13	Quick disconnect box 60-2004-228	2-16
2-14	4700 battery backup module	2-18

3-1 Control panel buttons	3-1
3-2 Suction line length	3-6
3-3 Time paced sampling program flow chart	3-13
3-4 Flow paced sampling program flow chart	3-14
3-5 Suction Head Height	3-21
4-1 4700 Sampler to RS-232 serial communication cable	4-6
4-2 Sample temperature report	4-6
4-3 Sliding the 24-bottle rack out	4-7
5-1 4700 Pump	5-2
5-2 Rollers (A) and guides (B) on the pump rotor	5-3
5-3 Wetted Parts	5-6
5-4 Temperature verification with the 24-bottle rack	5-13
5-5 Temperature verification with the bottle locating base	5-13

List of Tables

1-1 4700 Sampler Features	1-3
1-2 Specifications	1-4
2-1 Bottle Kits	2-4
2-2 Strainers	2-12
2-3 Unterminated Connect Cable	2-16
3-1 Control Buttons	3-1
3-2 Flow Pulse Intervals at Various Input Currents	3-16
4-1 4700 Errors	4-5
5-1 Replacement Pump Tubes	5-4
B-1 Hazardous Gases	B-6

List of Examples

Defining the Sample Volume	3-23
Time Paced Sampling Program	3-24
Flow Paced Sampling Program	3-26
Flow-proportional Constant Time Variable Volume Program	3-28
Resetting the Pump Tube Alarm	5-5

Isco 4700

Refrigerated Sampler

Section 1 Introduction

In this section...

- *Sampler Overview*
- *Features*, page 1-2
- *Specifications*, page 1-4

1.1 Sampler Overview

The 4700 Refrigerated Sampler is an automated wastewater sampler that can collect liquid samples from a variety of sources including open channels, sewers, and storm pipe conduits.

This indoor/outdoor use sampler is made of durable UV-resistant plastic that provides exceptional resistance to corrosion and weathering. Most notably, the refrigerator body is made from rotationally molded linear low-density polyethylene. This unique construction material was selected for its strength, durability, and its ability to withstand temperature extremes. The system is rated for -29 to 49 °C (-20 to 120 °F) operation. The hollow cavities are filled with foam insulation. To protect the non-CFC system, all refrigeration parts are powder coated with heat-treated polyester.

Unattended sample collection events can be triggered by time intervals (*time pacing*), or by flow volume measured by an external flow measurement device (*flow pacing* or *constant volume variable time*). Isco flow meters are compatible flow measurement devices, as well as any device that can provide a 5 to 15 VDC pulse or contact closure of at least 25 mS, or a linear 4-20 mA current loop signal. An external device can also disable the sampler until measured site conditions are met, at which time the sampler begins the automated collection.

The sampler's pump can deliver the liquid through a 9 mm ($\frac{3}{8}$ ") suction line at transport velocities of at least 0.9 meters per second (3.0 ft/sec) at 0.9 m (3.0 ft) of head. The transport velocity at 7.6 m (25 ft) of head is 0.67 m/sec (2.2 ft/sec). The maximum lifting height of the sampler is 8 m (28 ft). To produce accurate and repeatable samples, the pump uses a pump revolution counter and patented¹ non-contacting liquid detector.

The collected samples are stored inside the refrigerated compartment and cooled for sample preservation. Samples can be deposited into a single bottle (*composite*), or collected as discrete samples, each into a separate bottle of a multi-bottle rack (*sequential*), or a combination of these modes. The cooled samples are maintained until an operator can remove them from the sampler and deliver them to the laboratory.

1. United States patent 5,125,801

1.2 Features

The 4700 Series sampler features are identified in Figure 1-1 and described in Table 1-1.

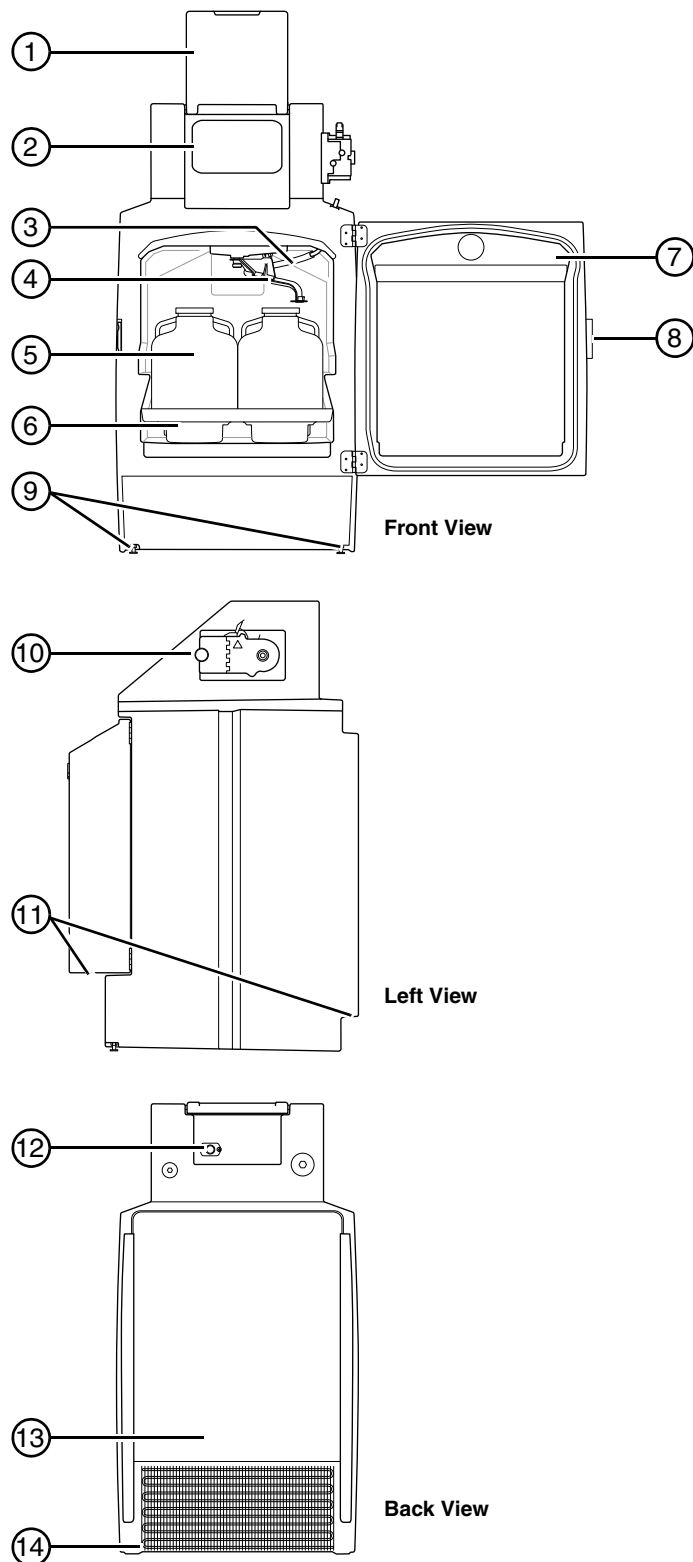



Figure 1-1 4700 Sampler features

Table 1-1 4700 Sampler Features

Item (Fig. 1-1)	Name	Description
1	Control Panel Cover	Protects the control panel display and keypad.
2	Control Panel	Supports user control and programming of sampler operation.
3	Discharge Tube	Carries liquid to the sample bottle. For 24, 4, 2, and 10 liter one-bottle configurations, the discharge tube is routed through the distributor arm. For the 20 liter one-bottle configuration the discharge tube is routed directly into the bottle.
4	Distributor Arm	Directs collected liquids to the bottle. Movement of the distributor is controlled by user-specified program settings.
5	Bottles	Hold the collected samples.
6	Bottle Locator Rack	Positions the bottles under the distributor.
7	Refrigerator Door	Protects the collected samples inside the refrigerated compartment.
8	Latch	Secures the door. The latch mechanism may be locked with a user-supplied padlock.
9	Level Adjustment Feet	The sampler includes two level adjustment feet at the front of the sampler. Use these to keep the bottle rack or locating deck level inside the refrigerated compartment.
10	Liquid Detector and Pump	The non-wetted liquid detector senses when the liquid is at the pump to determine head height and sample volumes. The peristaltic pump collects sample liquid and performs suction line rinses.
11	Lift Points	If you must lift the sampler, it can be safely handled at these points. Lifting must be done by two people, one on each side, with the door closed and latched.
12	External Device Connection	Supports connections to external devices such as a flow meter for sample pacing and enable signals, and connection to a personal computer for data collection.
13	Refrigeration Assembly	Modular, corrosion-resistant refrigeration assembly cools the refrigerated compartment to a user-selected temperature of 1 to 9°C (34 to 48°F).
14	AC Mains Line Cord	Connects to AC power source. <div style="display: flex; align-items: center;">  <p>The Mains Line Cord is the disconnect device.</p> </div>

1.3 Specifications

Table 1-2 Specifications		
Size (H×W×D):	130 × 72 × 84 cm	51 × 28 × 33 in
Weight (empty):	72 kg	159 lb
Bottle Configurations:	12 different configurations available: <ul style="list-style-type: none"> • 24 bottles, 1-liter PP or 350 ml glass; • 4 bottles, 10-liter PE or glass; • 2 bottles, 10-liter PE or glass; • 1 bottle, 20-liter PE or glass; • 1 bottle, 10-liter PE or glass; • 24 ProPaks, 1-liter wedge-shaped; • 1 ProPak, 10-liter round 	
Refrigerator Body:	Linear low-density polyethylene (LLDPE)	
Power Requirements:	100 VAC ±10%, 50 Hz Sampler Running current 1.4 amperes Stalled current 21.3 amperes 115 VAC ±10%, 60 Hz Sampler Running current 1.4 amperes Stalled compressor current 21.3 amperes 230 VAC ±10%, 50 Hz Sampler Running current 0.82 amperes Stalled current 17 amperes	
Installation Category:	II	
Pollution Degree:	3	
Maximum Altitude ^a :	2,000 meters	
Humidity:	0 to 100%	
Operational Temperature:	-29 to 49 °C	-20 to 120 °F
Pump		
Intake Suction Tubing Length:	1 to 30 m	3 to 99 feet
Material:	Vinyl or FEP-lined polyethylene	
Inside Diameter:	9 mm	³ / ₈ inch
Pump Tubing Life:	Typically 1,000,000 pump counts.	
Maximum Suction Lift:	8.5 m	28 feet
Typical Repeatability:	±5ml or ±5% of the average volume in a set, whichever is greater, at lifts up to 25 feet.	
Typical Delivered Volume Accuracy (Ability to repeat the delivered volume for a set of samples collected under the same conditions.):	±10ml or ±10% of programmed value, whichever is greater.	
Typical Line Velocity at Head Height:	0.9 m: 0.91 m/s 3.1 m: 0.87 m/s 4.6 m: 0.83 m/s 7.6 m: 0.67 m/s	3 ft: 3.0 ft/s 10 ft: 2.9 ft/s 15 ft: 2.7 ft/s 25 ft: 2.2 ft/s
Liquid Presence Detector:	Non-wetted, non-conductive sensor detects when liquid sample reaches the pump to automatically compensate for changes in head heights.	

Table 1-2 Specifications (Continued)

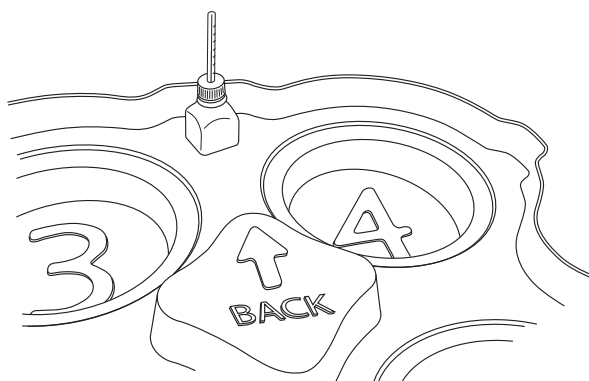
Controller	
Enclosure Rating:	IP67 NEMA 4X, 6
Program Memory:	Non-volatile ROM (Flash)
Flow Meter Signal Inputs:	5 to 15 volt DC pulse or 25 millisecond isolated contact closure for Isco flow meters. 4-20 mA input for non-Isco flow meters.
Digital Alarms:	4 programmable outputs; 5 VDC, 100 mA
Number of Composite Samples:	Programmable from 1 to 999 samples.
Software	
Sample Frequency:	1 minute to 99 hours 59 minutes, in 1-minute increments. 1 to 9,999 flow pulses.
Sampling Modes:	<ul style="list-style-type: none"> • Constant Time, Constant Volume • Variable Time, Constant Volume • Constant Time, Variable Volume (Variable time and variable volume modes are controlled by an external flow meter signal)
Programmable Sample Volumes:	10 to 9,990 ml in 1 ml increments.
Sample Retries:	If no sample is detected, up to 3 attempts; user selectable.
Rinse Cycles:	Automatic rinsing of suction line up to 3 rinses for each sample collection.
Controller Diagnostics:	Tests for RAM, ROM, pump, display, and electrical components.
Refrigeration	
Temperature Accuracy	<p>±1 °C from average temperature over a 48 hour period.</p> <p>Bottle configuration: 1 X 2.5 gal. polyethylene. Tested with setpoint 3°C, ambient temperature 20°C, in 30ml glycol bottle located on rack between rear rack locations 3 and 4 (see figure below).</p> <div style="text-align: center;">  </div>

- a. The maximum altitude rating is per European Norm 61010-1, which establishes safety requirements for electrical equipment. The rating pertains to electrical creepage and clearances. The rating is not applicable to pump performance.

Isco 4700 Refrigerated Sampler

Section 2 Installation

In this section...

- *Unpacking the Sampler*
- *4700 Sampler Installation Instructions*

2.1 Unpacking the Sampler

Carefully unpack the shipment and locate the packing list. Verify receipt of all components against this packing list. If there is any damage to the shipping carton or any components, contact the shipping agent and Teledyne Isco (or its authorized representative) immediately.

WARNING

If there is any evidence that the sampler has been damaged in shipping, do not plug it into an AC power source. Contact Teledyne Isco or its authorized representative for advice. Compare the contents of the boxes with the enclosed packing slip. If there are any shortages, contact Teledyne Isco immediately.

2.2 4700 Sampler Installation Overview

The following sections provide general instructions for placing the sampler into operation. In typical applications, the steps are:

1. Position the sampler. (Section 2.3)
2. Install a bottle kit. (2.4)
3. Attach the suction line. (2.5)
4. Attach a strainer. (2.6)
5. Route the suction line and strainer. (2.7)
6. Connect external instruments. (2.8)
7. Connect power. (2.9)
8. Configure and program the sampler. (2.10)
9. Lock the sampler. (2.11)

2.3 Positioning the Sampler

There are a few considerations when selecting a site for the sampler. The foremost concern should be personal safety.

WARNING

The installation and use of this product may subject you to dangerous working conditions that can cause you serious or fatal injuries. Take any necessary precautions before entering the worksite. Install and operate this product in accordance with all applicable safety and health regulations, and local ordinances.

 **WARNING**

If this product is used in a manner not specified in this manual, the protection provided by the equipment may be impaired.

 **WARNING**

This product has not been approved for use in hazardous locations as defined by the National Electrical Code.

 **WARNING**

The sampler is heavy. When lifting, use a two-person lift at the points identified in Table 1-1. When possible, move the sampler using a two-wheeled hand cart from the left or right side. To prevent damage to the refrigeration system, do not tip the sampler more than 45°.

- *Dangerous locations* – If you must enter a manhole, confined space, or other dangerous location to install the suction line and strainer, observe standard safety precautions. Refer to Appendix B for a discussion of safety considerations.
- *Support* – The sampler should be installed on a surface capable of safely supporting the sampler, full liquid containers, and personnel.
- *AC Power* – The mains line cord is the disconnect device should you need to remove power. Therefore, the electrical power outlet should be accessible.
- *Environmental* – The sampler is designed for outdoor use. Refer to Table 1-2 for environmental specifications. When possible, avoid subjecting the sampler to chemical attacks and direct sunlight.
- *Avoid submersion* – Although the control panel will resist damage (rated IP 67; NEMA 4x, 6), the refrigerator system and bottle compartment cannot prevent the liquid from entering. Liquid entering the refrigeration system might permanently damage the sampler; liquid entering the bottle compartment might contaminate the collected samples. Liquid entering the electrical compartment for the refrigeration system might result in a short circuit and possible shock hazard.

- *Liquid sample collection point* – It is best to keep the distance between the sampler pump and the collection point as short as possible. The shorter distance will increase pumping efficiency and pump tubing life. Also, the pump inlet should be located above the liquid surface. Gravity will aid suction line rinses and allow the line to drain, thereby reducing the possibility of sample cross-contamination. Refer to Table 1-2 for maximum suction line lengths and suction head heights.
- *Security* – The location may need to provide some degree of security to prevent tampering or vandalism.
- *Accessibility* – The sampler must be installed in a location where personnel can easily exchange bottles and perform routine service.

The sampler requires about 2600 square centimeters (925 in²) of floor space. Additional space must be allowed in front of the sampler, at its left and right sides, and above the sampler. Refer to Figure 2-1. Do not block access to these areas. Obstructions will make routine servicing activities difficult or impossible.

The back of the sampler may be placed against a wall as long as air at the bottom of the refrigerator can flow freely to surrounding air. Unrestricted air flow behind and around the sampler will keep the refrigeration system working efficiently.

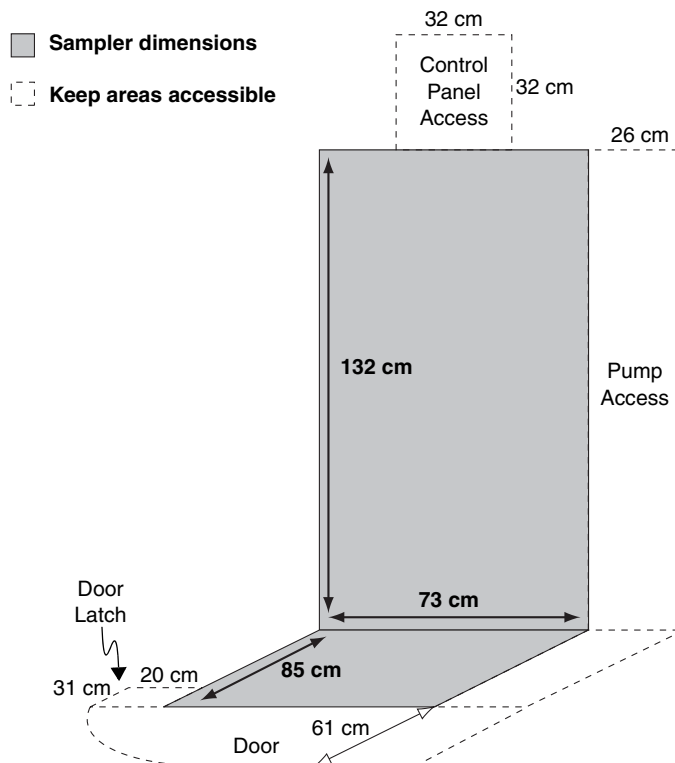

Figure 2-1 Minimum space requirements

- *Level surface* – The sampler should be placed on a level surface and the feet on the refrigerator body should be adjusted to prevent tipping or spills. If the sampler is not level, the sample liquid may miss the bottle mouth.

 **Note**

To level the sampler, place a bubble level on the installed bottle rack or locating base, then adjust the feet. For one-bottle configurations, place the bubble level on the side rails.

 **CAUTION**

Do not tip the sampler on its side or back. Tipping the sampler more than 45° might cause oil to run into the compressor inlet, which can permanently damage the sampler.

2.4 Installing a Bottle Kit

The 4700 sampler can hold 1, 2, 4, and 24 bottles. Each of these bottle configurations are supplied as a kit (see Table 2-1), which is normally ordered with the sampler or when you desire to change the bottle configuration.

Table 2-1 Bottle Kits

Part Number	Description
68-4700-003	24-bottle Configuration. Includes 24 polypropylene 1-liter wedge shaped bottles with caps, retaining ring, bottle rack and two discharge tubes.
68-4700-004	24-bottle Configuration. Includes 24 glass 350-ml round bottles with PTFE lined caps, retaining rings, bottle rack and two discharge tubes.
68-4700-017	24-Container ProPak Configuration. Includes 25 holders, 100 bags, retaining ring, bottle rack and instruction sheet.
68-4700-005	4-bottle Configuration. Includes four polyethylene 10-liter round bottles with caps, locating base and two discharge tubes.
68-4700-006	4-bottle Configuration. Includes four glass 10-liter round bottles with PTFE lined caps, locating base and two discharge tubes.
68-4700-007	2-bottle Configuration. Includes two polyethylene 10-liter round bottles, locating base, caps and two discharge tubes.
68-4700-008	2-bottle Configuration. Includes two glass 10-liter round bottles with PTFE lined caps, locating base, and two discharge tubes.
68-4700-009	1-bottle Configuration. Includes one polyethylene 2.5-gallon (10-liter) round bottle, locating base, two caps and two discharge tubes.
68-4700-010	1-bottle Configuration. Includes on glass 2.5-gallon (10-liter) round bottle, two PTFE lined caps, locating base, and two discharge tubes.
68-4700-018	Single ProPak Configuration for 4700 and 6700 Series FR Refrigerated Sampler. Includes one composite ProPak holder with cap, 100 ProPak bags, two discharge tubes and an instruction sheet.
68-4700-011	1-bottle Configuration. Includes one polyethylene 20-liter round bottle, two caps and two discharge tubes.
68-4700-012	1-bottle Configuration. Includes one glass 20-liter round bottle, two PTFE lined caps and two discharge tubes.

If you have selected a multi-bottle kit, first install the distributor arm and discharge tube (Section 2.4.1), then refer to the instructions for your selected bottle configuration:

- 24 Bottle configurations – section 2.4.2
- 4 Bottle configurations – section 2.4.3
- 2 Bottle configurations – section 2.4.4

If you have selected a single (composite) bottle kit, refer to the instructions in section 2.4.5.

For first-time use of the sampler, or if you have changed the bottle kit, be sure to configure the software for the new bottle kit (section 3.3.2).

2.4.1 Installing the Distributor Arm and Discharge Tube

The sampler is shipped with the distributor arm installed on its mounting shaft inside the refrigerator (Figure 2-2). It is generally easier to install the discharge tube with the arm removed, then you can reinstall the distributor arm. To do so:

1. Remove the knurled nut that secures the distributor arm.
2. Pull the distributor arm downward to remove it from the keyed shaft.
3. Thread the discharge tube through the body of the distributor arm.
4. Insert the end of the discharge tube into the outlet hole on the distributor arm. The end of the tubing should be flush with, or within 3 mm ($\frac{1}{8}$ ") of the lower edge of the hole.

CAUTION

The discharge tube should not extend below the hole in the distributor arm. This could cause the distributor to fail if the excess tubing catches a bottle.

5. Pull on the loose end of the discharge tube to remove any slack. The tube should follow the contour of the distributor arm.

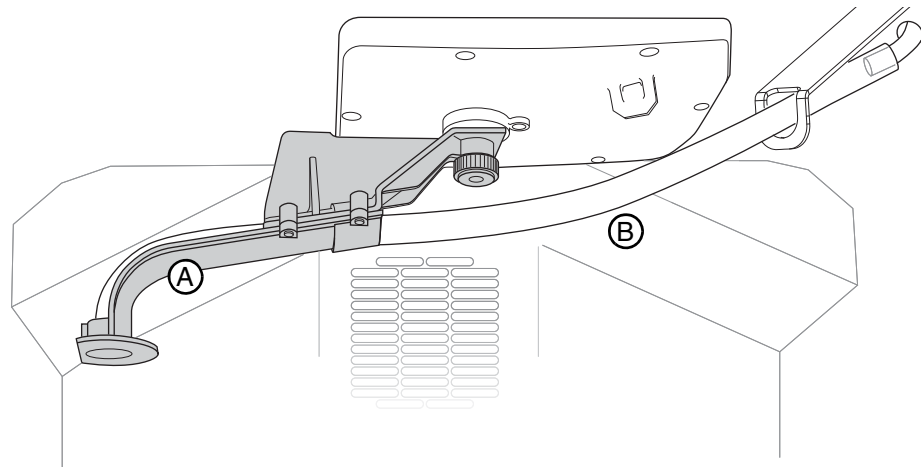

Figure 2-2 Installing the distributor arm (A) and discharge tube (B)

6. Push the distributor arm up onto the keyed shaft and secure it with the knurled nut.
7. Push the loose end of the discharge tube onto the bulkhead fitting in the top-front corner of the refrigerator.
8. Inspect the discharge tube:

 **CAUTION**

An incorrectly installed discharge tube can cause the distributor arm to fail. It can also cross-contaminate samples. To prevent these problems, inspect the discharge tube as described in the following steps.

- a. Manually rotate the arm to make sure that the tube does not obstruct its movement. If the tube obstructs arm movement, re-route the discharge tubing.
- b. The discharge tube must slope downward from the bulkhead fitting to the arm throughout the range of arm motion. Otherwise, liquid might pool in the tube and cross-contaminate samples.

Note that the discharge tube has a natural curve. Should the tube create a low spot where liquid can pool, twist the end of the tube connected to the bulkhead fitting so that the natural curve holds the tube in a downward sloping position. Then, retest the tube at other arm positions.

 **Note**

You can order replacement discharge tubes from Teledyne Isco. Order part number 60-9003-279 for a single tube. You can also order bulk tubing rolls from which you can cut to 20 inches (51 cm). Order part number 68-6700-046 for a 10-foot roll; 68-6700-047 for a 50-foot roll.

2.4.2 24 Bottles

The 24 bottle configurations use a rack to hold and align the containers. To install the bottles in the refrigerator using the rack:

1. Place the uncapped bottles in the rack (Figure 2-3).
2. If you are using 350 ml glass bottles, compress the retaining ring and place it in the center of the bottles. Release the ring and the outward force of the ring will secure the bottles. (The polypropylene and ProPak[®] bottles do not use a retaining ring.)

 **Note**

Bottle caps can be stored in the center of the bottle rack.

3. Locate the back of the rack (arrow, Figure 2-3). This end has a notch that fits a key on the refrigerator's rear wall.
4. Lift and insert the back of the rack into the refrigerated compartment.

✓ Note

There are four metal guides along the sidewall of the refrigerator, two on each side. The front two guides fit along the left and right sides of the rack. The back two guides run along the top of the rack to prevent the rack from tipping forward.

5. Slide the rack along the guides. Push the rack in until the left-side latch (inset, Figure 2-4) secures the rack.

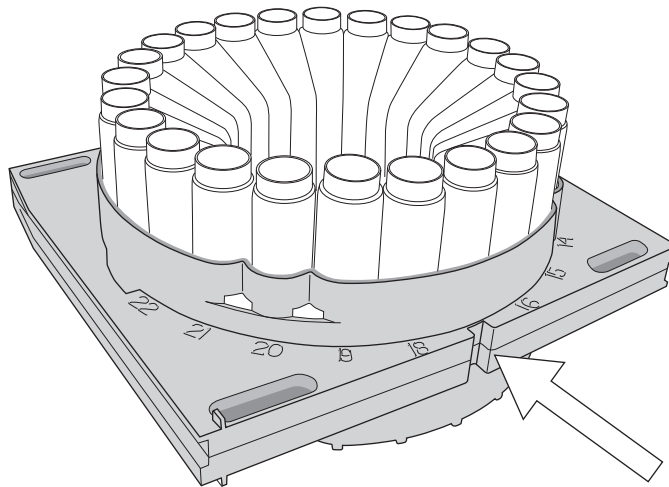

Figure 2-3 Insert the keyed end first so that it faces the back of the refrigerated compartment

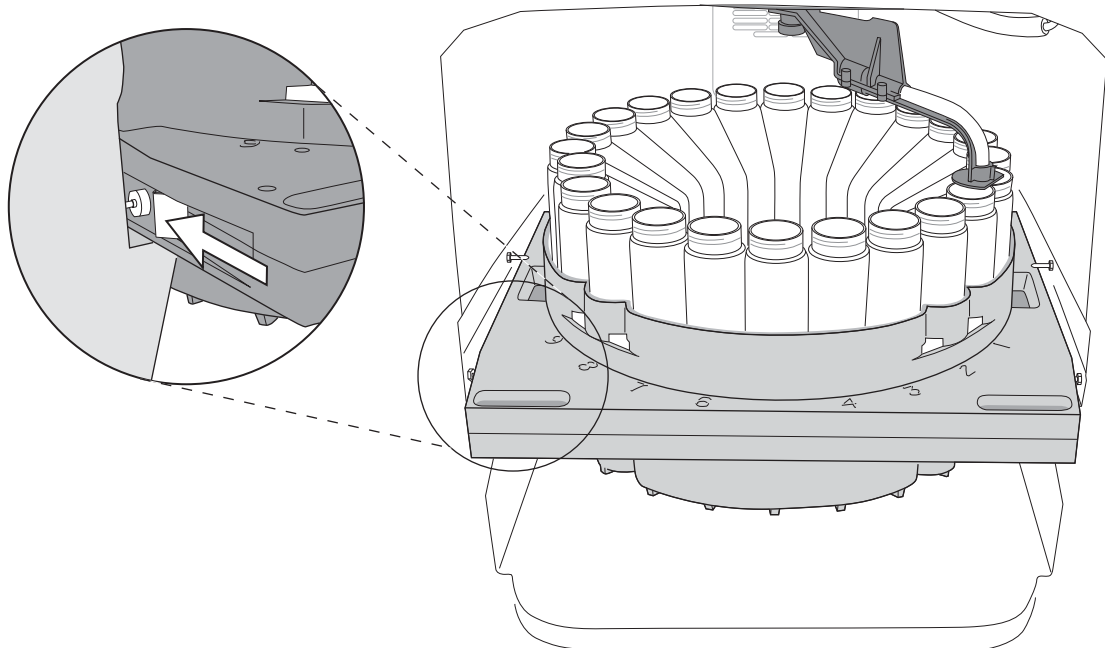

Figure 2-4 The 24-bottle rack is held in place by a latch on the left side

2.4.3 4 Bottles

The four bottle configuration uses a locating base to hold and align the bottles. To install the base and bottles:

1. Slide the locating base into the bottom of the refrigerated compartment (Figure 2-5). Note that the arrow must be pointing toward the back of the refrigerator.
2. Insert the four uncapped bottles into the numbered holes in the locating base.

Note

Bottle caps can be stored between the bottles.

2.4.4 2 Bottles

2.5 gallon bottles

The two bottle configuration uses a locating base to hold and align the bottles. To install the base and bottles:

1. Slide the locating base into the bottom of the refrigerated compartment (Figure 2-5). Note that the arrow must be pointing toward the back of the refrigerator.
2. Insert the two uncapped bottles into the holes numbered “1” and “2” in the locating base.

 **CAUTION**

When the sampler controller is configured for two bottles (section 3), samples will only be distributed to bottles 1 and 2. If you place the bottles in positions 3 or 4 the liquid will miss the bottle.

Note

Bottles caps can be stored between the bottles.

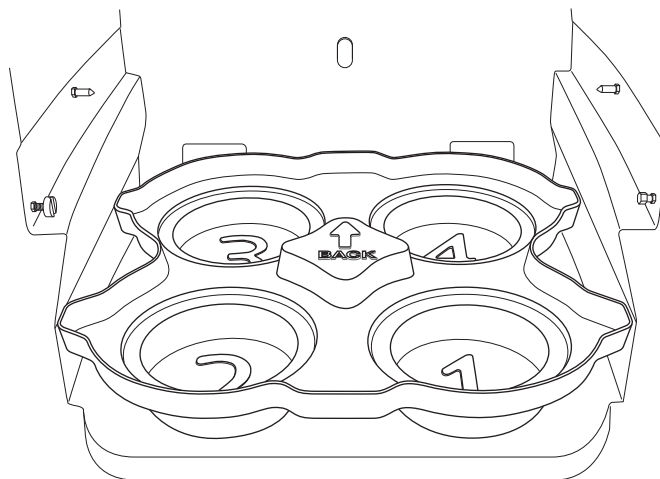

Figure 2-5 Installing the standard locating base

2.4.5 1 Bottle

If your one-bottle configuration has a 10 liter (2.5 gallon) polyethylene, glass, or ProPak bottle, use a locating base to hold and align the bottle. If your one-bottle configuration has a 20 liter (5 gallon) glass or polyethylene bottle, simply place the bottle in the center of the refrigerator; no rack or locating base is required.

Refer to the instructions for your bottle size.

10 liter bottle

To install the locating base and 10 liter bottle:

1. Slide the locating base into the bottom of the refrigerated compartment (Figure 2-5). Note that the arrow must be pointing toward the back of the refrigerator.
2. Insert the bottle into the hole numbered “1” in the locating base.

 CAUTION
--

When the sampler controller is configured for a single 10 liter bottle (section 3), samples will only be distributed to bottle 1. If you place the bottle in any other position liquid will miss the bottle.

20 liter bottle

To install the 20 liter bottle:

The distributor arm should be removed to prevent it from being an obstruction while you replace the bottle. To remove the arm:

1. Remove the knurled nut that secures the distributor arm.
2. Pull the distributor arm downward to remove it from the keyed shaft.
3. Store the arm in a safe location for future use.

Then install the bottle:

4. Screw the cap with a hole onto the bottle.
5. Place the bottle in the center of the refrigerator.
6. Feed the discharge tube into the hole (see Figure 2-6).
7. Connect the other end of the discharge tube to the bulkhead fitting at the top-front corner of the refrigerator.

The discharge tube must slope downward from the bulkhead fitting to the bottle. Otherwise, liquid might pool in the tube and cross-contaminate samples.

Note that the discharge tube has a natural curve. Should the tube create a low spot where liquid can pool, twist the end of the tube connected to the bulkhead fitting so that the natural curve holds the tube in a downward sloping position.

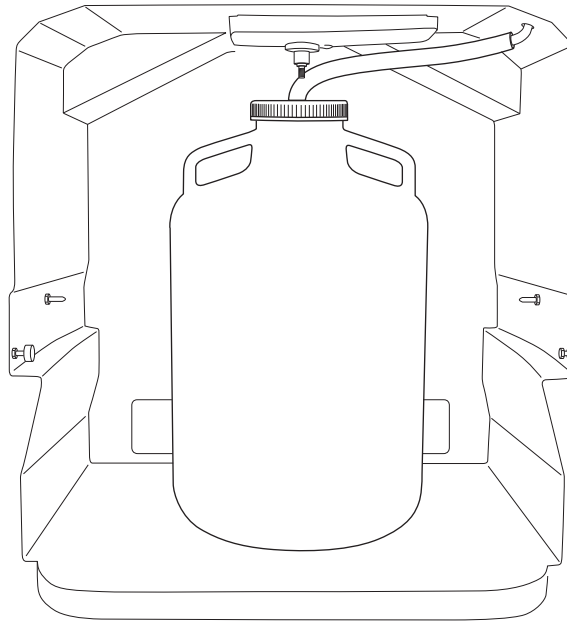

Figure 2-6 One 20 liter bottle configuration with discharge tube through the bottle cap

2.5 Attaching the Suction Line

The suction line is the tubing from the sampling point to the pump tube inlet. The sampler uses a $\frac{3}{8}$ -inch ID suction line of lengths from 3 to 99 feet. Teledyne Isco offers vinyl or FEP-lined suction lines. The FEP-lined tubing has a polyethylene jacket to protect it from kinks and abrasions.

The vinyl suction line contains a very low parts-per-million level of phenols. If phenol content affects your sample analysis, use the FEP-lined suction line.

Teledyne Isco ships suction line in standard lengths of 3.0 m (10 ft) or 7.6 m (25 ft). Either length should be cut to the shortest length feasible for the installation. When installed, the line should run the shortest possible distance from the collection point to the pump, preferably with a gradual upward slope. Excess suction line should be cut, not coiled. Coiled suction line will hold liquid between sample events which could cross-contaminate samples or freeze in cold climates. If the standard lengths are too short, or if you are cutting compatible $\frac{3}{8}$ -inch ID suction line from a bulk spool, you can use lengths up to 30 m (99 ft).

When accurate, repeatable sample volumes are important, use care to cut the suction line to the correct increments:

- When the sampler is using metric units of measure, cut the line in 0.1 m increments. For instance, cut 4.2 m, not 4.26 m.
- When using English units of measure, cut the line in increments of 1 foot.

Record this cut length. Later, you will enter this value in the SUCTION LINE configuration option (Section 3.3.4).

2.5.1 Vinyl Suction Line

Attach the vinyl suction line to the pump tube with the tubing coupler (part #69-4703-106). First, screw the threaded end into the suction line until the flat surface is flush against the suction line (Figure 2-7). Then, push the other end of the coupler into the end of the pump tube until the other flat surface is flush against the tubing.

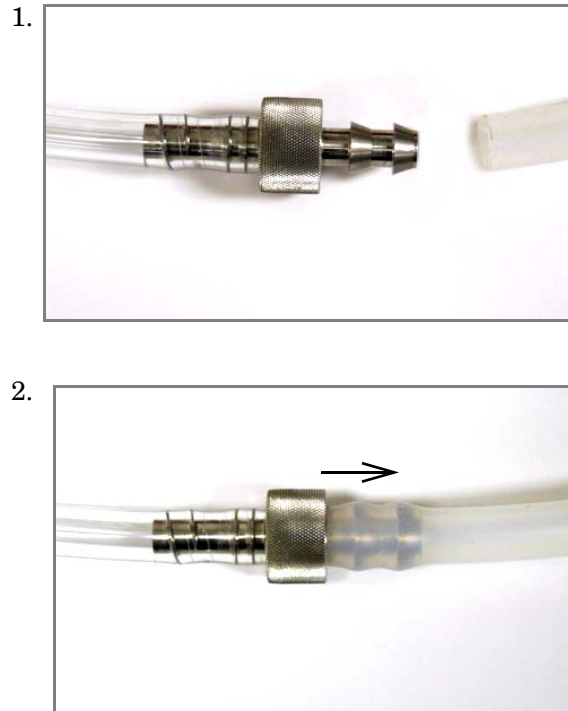

Figure 2-7 Attaching the suction line to the pump tubing

Once the coupler is attached to the pump tube, removal is difficult, and may require cutting the tube.

2.5.2 FEP-lined Suction Line

Inserting a tube coupler into FEP-lined suction line will damage the thin lining. Instead, refer to Figure 2-8 and the instructions below to attach FEP-lined suction line to the pump tube:

1. Slide a suitable clamp over the pump tube inlet.
2. Push about 20 mm of the FEP-lined suction line into the end of the pump tube.
3. Slide the clamp over the union and tighten. Do not over-tighten the clamp; this might cause the tubing to collapse or restrict the flow.

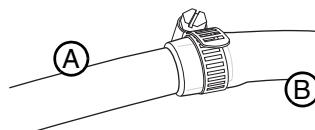

Figure 2-8 Connecting FEP-lined suction line (A) to pump tube (B)

2.6 Attaching a Strainer

To select the right strainer for your application, see Table 2-2 and Figure 2-9.

To attach the strainer to the suction line, carefully screw the strainer's threaded connector into the suction line. If attaching the strainer to an FEP-lined suction line, heat the end of the suction line before threading the strainer into the line. Warming FEP-lined tubing will make it more pliable to avoid damage.

Table 2-2 Strainers							
Part Number	Strainer	Application	dia. A	dia. B	length C	Maximum Unanchored Depth	
						Vinyl	FEP-lined
60-9004-367	Weighted Strainer-stainless steel ends, polypropylene center	Routine applications	10 mm 0.40 in	32 mm 1.25 in	267 mm 10.5 in	6.7 m 22 ft	4.5 m 15 ft
69-2903-138	Low Flow Strainer-Stainless Steel	Low flow applications	10 mm 0.40 in	14 mm 0.562 in	178 mm 7.0 in	6.7 m 22 ft	4.5 m 15 ft
60-3704-066	CPVC Strainer	Highly acidic liquids, metals sampling	10 mm 0.40 in	33 mm 1.3125 in	292 mm 11.5 in	1.2 m 4 ft	N/A

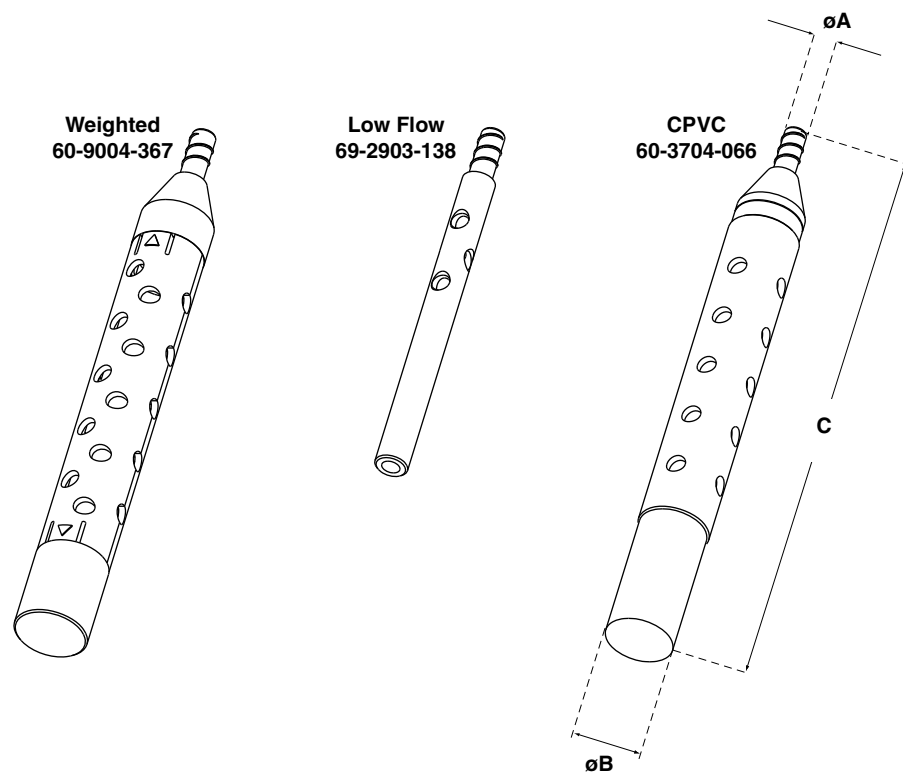

Figure 2-9 Strainers

2.6.1 Alternative to Strainers When sampling from high velocity streams with heavy suspended solids, some field investigations suggest that more representative samples are obtained without the strainer. Consider attaching a short piece of thin walled aluminum tubing to the end of the suction line; anchor the tubing so that the inlet opens upstream. The aluminum tubing's thin wall will not disturb the flow stream, and most sample analyses disregard aluminum ions. Under most conditions, the pre-sample line rinse removes any debris over the tubing entrance.

2.6.2 Maximum Unanchored Depth Table 2-2 lists maximum unanchored depths for each type of suction line. During a pre- or post-sample line rinse, the suction line is filled with air which might cause the suction line and strainer to float. If the depth of the strainer exceeds the listed value, securely anchor the strainer.

 **Note**

Even if the maximum depth is not exceeded, it is a good idea to anchor the suction line and strainer when sampling from high velocity or turbulent flow streams.

2.7 Routing the Suction Line and Strainer

Route the suction line so that it has a continuous slope from the liquid source to the sampler. This helps to drain the line during pre- and post-sample line rinses. If a suction line exposed to freezing climates does not fully drain, there is a risk of liquid in the suction line becoming frozen. Frozen liquid will cause the sample collection to fail. A warm sampling source can usually prevent this, provided there are no loops in the suction line. Some extreme situations may require more protective measures, such as insulating the suction line, or applying heat tape.

For representative samples, place the strainer in the main current of the flow stream, not in an eddy or at the edge of flow. Placing a strainer at the bottom may produce samples with excess heavy solids and no floating materials, while placing it at the top may produce the opposite conditions.

 **CAUTION**

This sampler has a high performance pump. As with all such pumps, it relies upon liquid to cool working components. If the sampler is programmed to pump in the absence of liquid in excess of 5 minutes, excessive heat buildup may damage the paddles, rollers, and housing. Ensure that the liquid inlet is completely immersed.

2.8 Connecting the Sampler to External Devices

You can connect the sampler to an external instrument (Figure 2-10) for a variety of reasons. Typical reasons include:

- Receiving flow pulses from a flow meter device for variable time or variable volume sample collection.
- Receiving an enable pin signal to enable sampler operation once site conditions warrant sample collection.
- Sending a three-second event mark at the beginning of every sample collection event.
- Receiving a linear 4-20 mA analog representation of the flow rate for variable time or variable volume sample collection.
- Sending alarm signals when user-specified sampler events occur.

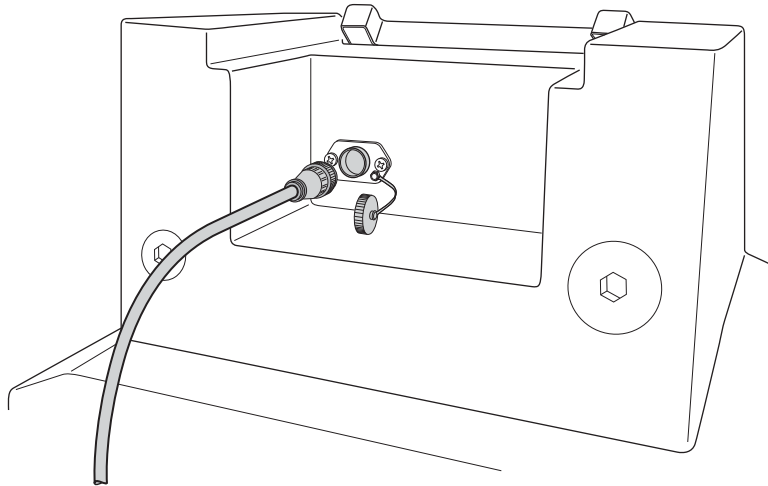

Figure 2-10 External device connection at rear of sampler

These types of connections can be categorized as *Standard Isco device connections* or *other device connections*. Each type is discussed in sections 2.8.1 and 2.8.2, respectively.

This rear-panel connection may also be used for communicating with a computer for the purpose of collecting reports. Please refer to section 4.3.2 for more information about this feature.

2.8.1 Standard Isco Instrument Connections

You can connect the sampler to an Isco 4100 Series flow logger or a 4200 Series flow meter. With these Isco instruments you can:

- Receive flow pulses for variable time or variable volume sample collection.
- Receive an enable pin signal to enable sampler operation once site conditions warrant sample collection.
- Send a three-second event mark at the beginning of every sample collection event.
- Power the flow measurement device.

To connect either of these instruments, use the optional 7.6 m (25 ft) connect cable, 69-4704-043 (Figure 2-11).

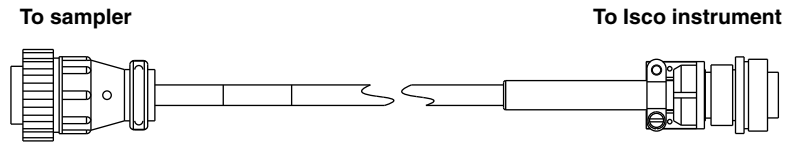

Figure 2-11 4700 Sampler to Isco flow meter cable

2.8.2 Other Device Connections

You can connect the sampler to receive a 4-20 mA signal from an external device, including Isco's 2108 and accQcomm™ analog output modules. You can also connect the sampler to a non-Isco device to receive flow pacing and enable pin signals, to send sample event marks and alarm signals, or to supply 12 VDC power.

All of these types of connections use the optional unterminated connect cable, P/N 68-4700-020 (Figure 2-12). This 3 m (10 ft) cable is unterminated at the device end to allow wired connections to compatible circuits. Refer to Table 2-3 for wire identification and connection details.

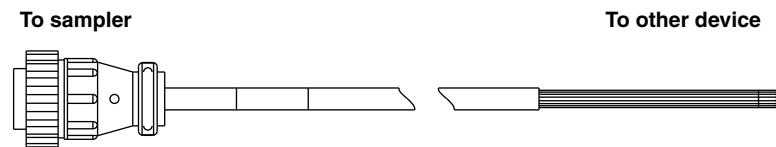

Figure 2-12 4700 Sampler unterminated connect cable

CAUTION

Risk of equipment damage. Only experienced electronic technicians should make the connections to an external device using cable 68-4700-020.

To connect the external device, refer to Table 2-3 and select the appropriate wires. Splice the wires by soldering or using crimped connectors. Trim back the tinned ends of any unused wires and provide appropriate electrical insulation. To complete the connection, be sure to protect it from the environment. Running the cables through conduit and making the connections inside a watertight electrical box generally provides adequate protection.

Note

The Isco Quick Disconnect (Q.D.) box, P/N 60-2004-228, can provide a convenient, watertight connection to wiring from a non-Isco device. The sealed IP67 (NEMA 4x) enclosure contains seven terminal blocks and is equipped with a mounting plate. **The hazardous location rating of Q.D. box does not apply when used with an Isco sampler.**

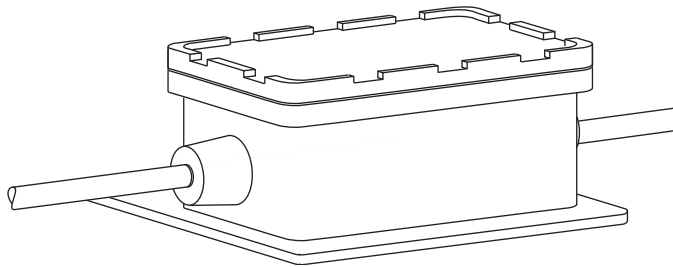

Figure 2-13 Quick disconnect box 60-2004-228

Table 2-3 Unterminated Connect Cable ^a				
Pin	Wire Color ^b	Signal Name	Sampler Input/Output	Parameters/Comments
1	Black	12 VDC Power	Output	+12.5 VDC, 1 ampere maximum. Power for external devices.
2	White	Ground	N/A	Common ground
3	Green	Flow Pulse	Input	25 millisecond (minimum) pulse, +5 to +15 VDC
4	Blue	Serial Data	Output	For use with PC connections. Cable 69-4704-042 is recommended. See section 4.3.2.
5	Orange	Event Mark	Output	3 second, +12 VDC pulse at beginning of sample collection
6	Red	Enable Pin ^c	Input	Ground this input (short to pin 2) to disable sampler operation. Leave this input open (floating) to collect samples.
7	White/Black	12 VDC	Output	+12.5 VDC, 1 ampere maximum. Power for external devices.
8	Red/Black	Alarm 1 ^d	Output	Alarm Off = 0 VDC, Alarm On = +5 VDC
9	Red/White	Alarm 2 ^d	Output	Alarm Off = 0 VDC, Alarm On = +5 VDC
10	Orange/Black	Alarm 3 ^d	Output	Alarm Off = 0 VDC, Alarm On = +5 VDC
11	Green/Black	Alarm 4 ^d	Output	Alarm Off = 0 VDC, Alarm On = +5 VDC
12	Green/White	Analog 4-20 mA (+)	Input	Linear current loop signal representing minimum flow rate at 4 mA, maximum flow rate at 20 mA. This input is paired with pin 13.
13	Blue/White	Analog 4-20 mA (-)	Input	See pin 12.
14	Blue/Black	Ground	N/A	Common ground. Same as pin 2.
15	Black/White	N/A	N/A	Not used
16	Bare	N/A	N/A	Not used

- a. All voltage measurements are referenced to common ground on pins 2 and 14.
- b. For color pairs, the first named color is the predominant color; the second named color is the spiral stripe around it.
- c. This pin is also used as the Serial Data Input for use with PC connections. Cable 69-4704-042 is recommended instead for a serial data connection. See section 4.3.2.
- d. Output from internal driver is current limited to 100 mA maximum. The output between the alarm pin and ground can drive low-power alarm devices rated for 5 VDC. Control higher-power (>100 mA) devices, or devices with different voltage requirements through a user-supplied relay. See section 3.3.9 to configure alarm conditions.

2.9 Connecting Power

 **WARNING**

Before connecting the sampler to an AC power source, be familiar with the *Electrical Requirements* listed on page v at the front of this manual.

The factory assembles the sampler for either 100VAC/50 Hz, 115 VAC/60 Hz, or 230 VAC/50 Hz. The serial number label located inside the refrigerator identifies the AC power configuration of your sampler. You cannot convert the sampler in the field without purchasing a replacement refrigeration module.

The mains power cord for 115 VAC samplers is equipped with a NEMA 5-15P plug for standard North American outlets. The mains power cord for 230 VAC samplers is equipped with an EU-16P plug for standard CEE-7 European outlets. For other types of outlets that supply compatible AC power, convert the mains power cord plug with a locally-purchased adapter.

Plug the mains power cord into the outlet. The sampler control panel will briefly show the start up displays.

Copyright 2006
TELEDYNE ISCO

4700 SAMPLER

2.9.1 Backup Power

The 4700 is capable of switching the sampler controller to backup power from an Isco power supply in the event of AC power loss. Older models can be modified to have this capability.

 **Note**

This provides backup power to the sampler controller only; not to the refrigerator.

To enable power backup, connect the module (60-5314-696) to the 16-pin connector on the back of the sampler (Figure 2-14). Connect the Isco power supply to the 2-pin amphenol connector on the module. The module duplicates the 16-pin connector to allow connection to other devices.

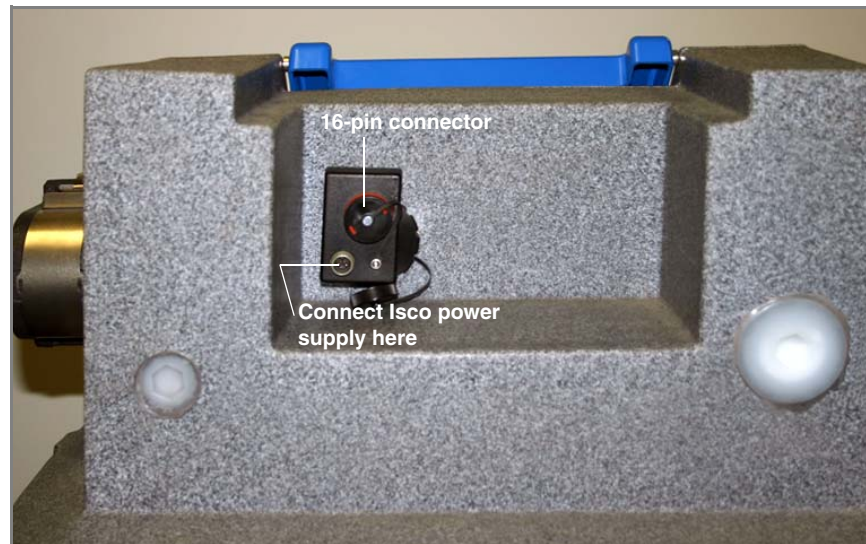

Figure 2-14 4700 battery backup module

2.10 Configuring and Programming the Sampler

To complete the installation, the sampler software should be configured and programmed. Refer to Section 3 for instructions.

Configure the sampler to make sure that it “knows” what bottle configuration is installed, the length of the suction line, *etc.* Program the sampler to specify how and when the sampler should collect liquid samples.

2.11 Locking the Sampler

Locking the sampler is an optional step that can prevent tampering with the sampler operation or collected samples.

To prevent tampering with the sampler operation, the sampler has a PROGRAM LOCK. When enabled, this software feature requires a numeric password to access most of the control panel functions. Refer to section 3.3.11 to enable this option.

To prevent tampering with the collected samples, place a padlock on the refrigerator door latch.

Isco 4700 Refrigerated Sampler

Section 3 Programming

In this section...

- *Control Panel Description*
- *Getting Started*, page 3-2
- *Configuring the Sampler*, page 3-3
- *Sampling Program Overview*, page 3-12
- *Programming Steps*, page 3-15
- *Programming Examples*, page 3-22

3.1 Control Panel Description

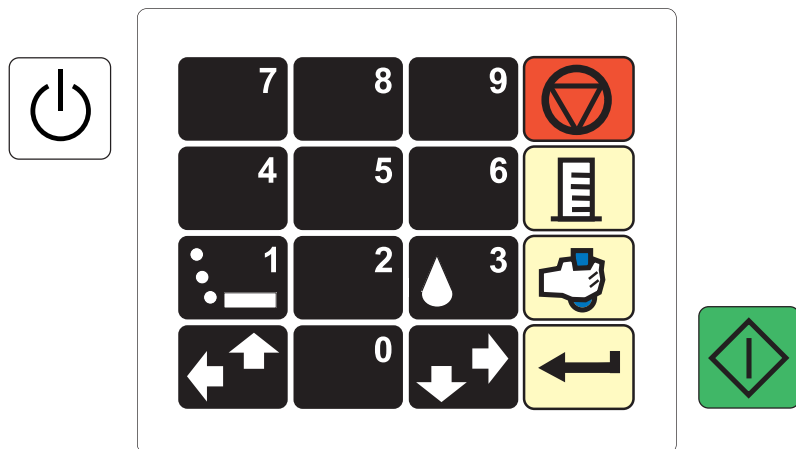

Figure 3-1 Control panel buttons











Table 3-1 Control Buttons		
Icon	Name	Description
	Standby	Places the sampler in the On or Standby modes. Note: In either modes, mains power is always connected to the refrigeration system.
	Numbers	Types a number.
	Pump Reverse (Purge)	At the Main menu, press this button to run the pump in the reverse direction to purge the suction line. In other menus, press this button to type the number 1.
	Pump Forward (Fill)	At the Main Menu, press this button to run the pump in the forward direction to fill the suction line. In other menus, press this button to type the number 3.

Table 3-1 Control Buttons (Continued)

Icon	Name	Description
	Previous	Selects the previous menu option left or above the current choice.
	Next	Selects the next menu option right or below the current choice.
	Stop, Cancel, or Exit	Stops the pump or distributor. Pauses a running sampling program. In programming screens, returns to the previous programming level.
	Calibrate	Press this button from the Main Menu to enter the Calibration mode.
	Grab Sample	Press this button from the Main Menu or the Paused state to take a grab (manual) sample.
	Enter	Accepts a menu choice or number entry and goes to next screen.
	Run Program	Press this button to start the sampling program.

3.2 Getting Started

Apply power to the sampler (see section 2.9). The *start-up screens* appear on the LCD display.

Copyright 2006
TELEDYNE ISCO

4700 SAMPLER

After completing the start-up routine, turn the sampler on by pressing the Power button. The control panel displays the Main Menu screen and waits for your input.

PROGRAM CONFIGURE
VIEW LOG

The Main Menu screen displays three menu options. The active option blinks. To change the active option, use the Next and Previous buttons. Press the Enter button to choose the blinking active option.

If you have just installed the sampler, you will first need to configure the sampler (section 3.3). Next, you will need to program it for operation (section 3.4). The View Log option (section 4.3) will not contain meaningful data until you have run a sampling program.

3.3 Configuring the Sampler

Before operating the 4700 Sampler, configure the sampler software. Doing so will set the time and date, and allow the sampler controller to correctly use the hardware and external connections.

To begin from the Main Menu, press the Next or Previous button until the CONFIGURE option blinks. Then, press the Enter button. The sampler displays the first configuration setting.

You can step through the Configure options using the Next or Previous buttons. To review or change the settings for the displayed option, press the Enter button.

The sampler will return to the SELECT OPTION <- -> screen when there are no more settings for the selected option. To return to the SELECT OPTION <- -> screen sooner, press the Stop button. Pressing the Stop button at any input screen will exit the current screen without saving changes. You can press the Stop button again to exit the sampler configuration screens and return to the Main Menu screen.

3.3.1 Set Clock

Select this option to set the sampler's internal clock to your local time and date. The sampler uses this internal clock to start and stop sample programs, and to time stamp events in the log.

SELECT OPTION: (<-->)
SET CLOCK

1. Press Enter.

ENTER TIME AND DATE:
HH: MM DD-MON-YY

2. Press the Number buttons to type the hours (using 24-hour format). Then, press Enter to accept the hours and move to the minutes. Repeat for all settings and the display will return to the SELECT OPTION <- -> screen.

About Times and Dates

FIRST SAMPLE
08:00 16-JUN

Times —

When entering times, use the 24-hour format, sometimes known as "military time." In this format, times after 12:00 noon continue to increment (1:00 pm = 13:00, 2:00 pm = 14:00, etc.), until midnight or 00:00.

ENTER TIME AND DATE:
HH: MM DD-MON-YY

Dates —

When entering dates, use a day-month-year format. Although the screens above display the date as a three-character abbreviation and a two-digit numeric value, months are always entered by typing the numeric value (1=January, 2=February, and so on).

3.3.2 Bottles and Sizes-Standard

SELECT OPTION: (<-->)
BOTTLES AND SIZES

NUMBER OF BOTTLES:
1 2 4 24

BOTTLE VOLUME:
___ ml (300-65500)

Select this option to specify the installed bottle configuration (section 2.4). The sampler uses this setting to determine available bottle options and control the operation of the distributor.

1. Select the BOTTLES AND SIZES option and press Enter.
2. Press the Previous or Next buttons to highlight the installed bottle configuration. Press Enter to select it.
3. Press the Number buttons to enter the bottle volume in milliliters. For multi-bottle samplers, enter the bottle volume of one bottle, not the total volume of all bottles.
If you enter a non-standard bottle volume, the sampler will ask "ARE YOU SURE?". Answer NO to re-enter a standard volume or answer YES to confirm the non-standard volume.

3.3.3 Bottles and Sizes-Custom

PROGRAM CONFIGURE
VIEW LOG

OPTION_____

PROGRAM CONFIGURE
VIEW LOG

Custom bottle configurations require software enhancement 1709 in order to position the distributor over the bottles. The custom software must be activated from the control panel before it can be used. To confirm program entries, press Enter each time.

1. At the initial screen, enter 47009.
2. Enter 1709.
3. Enter 2688537.
4. Enter the number of bottles in your configuration.
5. Enter bottle locating numbers, depending on your configuration:

2 x 20L bottles

- Btl 1 = 100
- Btl 2 = 800

2 x 3.5 gallon glass bottles

- Btl 1 = 200
- Btl 2 = 705

8 x 1.8L bottles

- Btl 1 = 275
- Btl 2 = 575
- Btl 3 = 875
- Btl 4 = 1175
- Btl 5 = 1475

- Btl 6 = 1775
- Btl 7 = 2075
- Btl 8 = 2350

4 x 20L bottles

- Btl 1 = 335
- Btl 2 = 900
- Btl 3 = 1525
- Btl 4 = 2150

PROGRAM CONFIGURE
VIEW LOG

6. Select CONFIGURE, scroll to BOTTLES AND SIZES, and press Enter.
7. Select SPA.
8. Enter the bottle volume for your bottle type:
 - 2 x 20L = 19,000
 - 2 x 3.5 gallon = 12,500
 - 8 x 1.8L = 1,700
9. Exit CONFIGURE mode.

3.3.4 Suction Line

Select this option to enter the suction line length (section 2.5). The sampler uses this input along with the pump tables it creates to determine the duration of the pump fill and purge cycles and to calculate sample volumes.

To set the suction line length:

SELECT OPTION: (<-->)
SUCTION LINE

SUCTION LINE LENGTH:
___ ft (3-99)

PLEASE WAIT!
CREATING PUMP TABLES

1. Select the SUCTION LINE option and press Enter.
2. Press the Number buttons to enter the suction line length.
3. The sampler creates pump tables before returning to the SELECT OPTION <--> screen.

When accurate, repeatable sample volumes are important, use care to cut the suction line and enter the correct measurement.

If using English units of measure, cut the suction line to the nearest whole foot. When using metric units of measure, cut the suction line to the nearest 0.1 meter. The sampler displays units of measure appropriate for the selected language (see section 3.3.12).

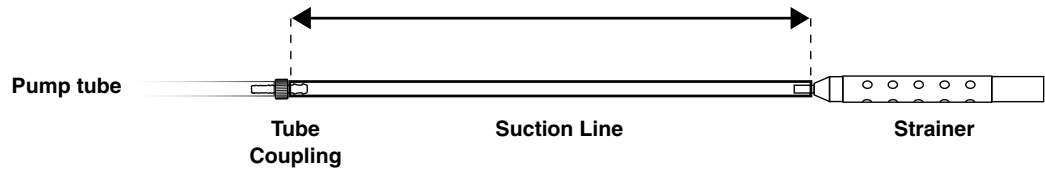

Figure 3-2 Suction line length

3.3.5 Liquid Detector

Select this option to turn liquid detection on or off. This setting also allows you to configure suction line rinses and sample retries.

SELECT OPTION: (<-->) LIQUID DETECTOR
USE LIQUID DETECTOR? YES NO
___ RINSE CYCLES (0-3)
RETRY UP TO ___ TIMES WHEN SAMPLING (0-3)

1. Select the LIQUID DETECTOR option and press Enter.
2. Select YES (the factory default) for improved sample volume accuracy, and to enable Rinse Cycles and Sampling Retries. Select NO to turn off all of these features and return to the SELECT OPTION <- -> screen.
3. Press a Number button to specify how many rinse cycles should be performed before collecting a sample.
4. If the sampler fails to detect liquid, it can try again to collect the sample. Press a Number button to specify how many retries the sampler should attempt.

For most sampling applications you should use Liquid Detection. Selecting NO may adversely affect sample volume repeatability and will turn off Rinse Cycles and Sampling Retries.

You can use Rinse Cycles to condition the suction line and strainer before collecting a sample. Rinse Cycles may also improve sample volume repeatability by ensuring the suction line is wetted before each sample. One rinse cycle draws liquid through the suction line until it reaches the Liquid Detector. Then, the pump reverses direction and to clear the suction line.

Note that Rinse Cycles add to the Pump Counts (section 3.3.10) and requires more frequent pump tube changes.

3.3.6 Flow Mode Sampling

Select this option to indicate whether or not the sampler should take a sample when the Run Program button is pressed. The Sample At Start option is only applicable to Flow Paced programs.

SELECT OPTION: (<-->) FLOW MODE SAMPLING
SAMPLE AT START? YES NO

1. Select the FLOW MODE SAMPLING option and press Enter.
2. Select YES to take the first sample when the start time is reached. Select NO to wait until the flow count triggers the first sample.

If you select YES, when you run the program the sampler takes the first sample immediately (if NO DELAY TO START, see section 3.5.18) and starts counting flow pulses for the next interval.

3.3.7 Enable Pin

Select this option to specify which actions the sampler controller should take when the Enable Pin state changes. The Enable Pin feature allows an external device (section 2.8) to control the running programs.

```
SELECT OPTION: (<-->)
ENABLE PIN
```

```
REPEATABLE ENABLE?
YES NO
```

```
SAMPLE AT ENABLE?
YES NO
```

```
RESET SAMPLE
INTERVAL? YES NO
```

1. Select the ENABLE PIN option and press Enter.
2. Select YES for unlimited enable/disables. Select NO to allow only one enable, after which the sampler will remain enabled until the end of the program sequence.
3. If your application requires a sample when the sampler becomes enabled, select YES. Otherwise, select NO and the sampler will take the first sample at the programmed interval.
4. Select YES to reset the time or flow pacing interval to zero at the moment the sampler becomes enabled. Select NO and the sampler will continue with the current count.

The sampler controller is disabled when pin 6 of the External Device connector is held at ground potential. Isco devices do this by shorting pins 6 (Enable) and 2 (GND) together. A non-Isco device can disable the sampler by using a relay contact closure to short these two pins together. The sampler is enabled when pins 6 and 2 are no longer shorted, that is, pin 6 is open or allowed to float.

One application that illustrates the enable feature is parameter monitoring at the head works of a treatment plant. As long as the measured parameter (pH, for example) is within the normal range, the monitoring instrument disables the sampler. When the parameter exceeds the normal range, the instrument enables the sampler, which then collects samples at intervals specified by the program.

3.3.8 Refrigeration

Select this option to set the target temperature of the refrigeration system. The sampler will operate the cooling or heating systems as needed to maintain this target temperature.

```
SELECT OPTION: (<-->)
REFRIGERATION
```

```
TARGET TEMPERATURE
_ C (1-9)
```

```
QUICK COOL FOR FIRST
DAY? YES NO
```

1. Select the REFRIGERATION option and press Enter.
2. Use the Number buttons to set the target temperature as degrees Celsius. Press Enter to save the setting.
3. **Single Bottle Only** — Select YES to enable the Quick Cool mode, NO to disable it.

Quick Cool lowers the target temperature by 2.5°C for the first 24 hours. This feature can be quite useful when collecting warm liquids or larger sample volumes to draw down the temperature quickly. To prevent the sample from

freezing, Quick Cool will not lower the target temperature below 0.5°C.

3.3.9 Output Pins

Select this option to configure the four alarm outputs. An alarm output is based one of the following events:

- **PROGRAM STARTED** – This event occurs when the Start Time is met. For programs using NO DELAY TO START, this will occur immediately when you press the Run button. The alarm output signal lasts three seconds.
- **PROGRAM COMPLETED** – This event occurs when a running sampling program has finished. This alarm output stays on as long as the run time display reads PROGRAM COMPLETED.
- **PUMP ERROR**– This event occurs when the sampler has detected a pump failure or an absence of liquid. This condition must be corrected before the sampling program can resume. This alarm output stays on until the pump is successfully operated or liquid is again present.
- **DISTRIBUTOR JAMMED** – This event occurs when the sampler has detected a distributor failure. This condition must be corrected before the sampling program can resume. This alarm output stays on until the distributor is successfully operated.
- **3-WAY VALVE CONTROL** – This event occurs whenever a sample is initiated and controls the optional Three-way Valve. This sampler option is useful when collecting samples from a pressurized line. For more information about the optional Three-way valve option and sampling from pressurized lines, contact your Isco dealer or the Teledyne Isco factory.
- **TAKING SAMPLE** – This event occurs each time a sample is taken. The alarm output stays on until the sample event is completed.
- **PUMPING FORWARD** – This event occurs for the duration of the forward pumping step of a sampling event (between pre- and post-purge).
- **POWERED UP** – This event occurs when power is supplied to the sampler.
- **PUMPING REVERSE** - This event occurs for the duration of the reverse pumping steps of a sampling event (pre- and post-purge). Is is also active for manual reverse pumping.
- **BOTTLE FULL** – This event occurs if a composite program using a bottle larger than 10,500 ml purges liquid from the sample bottle. Sample volumes larger than 60 ml and a post-sample purge larger than 100 counts are required for this alarm. The alarm will not occur until after the first five samples have been taken.

This allows the sampler to determine normal operating conditions. The alarm remains on until a key is pressed to exit this screen.

Note: A bottle full condition will not halt a running program unless a BOTTLE FULL output is selected.

- DELAY BEFORE SAMPLE – This event occurs at the start of a sample event prior to movement of the distributor arm. When you select this output, you will be prompted to enter a delay time between 1 and 99 seconds.

To configure the alarm output pins:

```
SELECT OPTION: (<-->)
OUTPUT PINS
```

```
SET OUTPUT _: (<-->)
PROGRAM COMPLETED
```

1. Select the OUTPUT PINS option and press Enter.
2. Press the Previous or Next buttons to select an event type for the displayed output channel.
3. Press the Enter button to select the event type and advance to the next output channel.

Repeat until all four alarm outputs are programmed.

Refer to section 2.8 for details on connecting the alarm output pins to external devices.

3.3.10 Tubing Life

Select this option to view and reset the pump counts. The Tubing Life feature serves as a reminder so you can replace the pump tube at regular intervals before its wall cracks and ruptures. Several problems may arise from a weak or ruptured pump tube:

- The sampler will not pump the liquid
- Pump jams
- Inaccurate sample volumes
- Faulty liquid detection

To set the Tubing Life reminder:

```
SELECT OPTION: (<-->)
TUBING LIFE
```

```
__ PUMP COUNTS,
WARNING AT __00000
```

```
RESET PUMP COUNTER?
YES NO
```

```
__00000 PUMP COUNTS
TO WARNING
```

1. Select the TUBING LIFE option and press Enter.
2. The sampler displays the current pump count. The display automatically advances in four seconds or press Enter to continue.
3. If you have replaced the pump tube, use the Next and Previous buttons to select YES, then press Enter. Otherwise, select NO.
4. Enter an interval using the Number buttons and press Enter. (The default value is “5.”)

The sampler counts pump revolutions in both the forward and reverse cycles with a resettable counter. When the counter reaches the default of 1,000,000 counts, the sampler displays an alert message, “WARNING! CHANGE PUMP TUBE.” After replacing the pump tube (see section 5.1.2), reset the count to zero so the sampler can begin tallying the pump counts for the new tube.

Note

Opening the pump housing and replacing the pump tube will not reset the counter.

The default count of 1,000,000 represents the average interval at which the pump tube should be inspected. Because liquid properties and site conditions affect the life of the pump tube, you can change this interval to better suit your application. If a pump tube inspection (section 5.1.1) at 1,000,000 counts reveals little or no wear, this value can be increased to avoid needless replacements. Conversely, if an inspection reveals significant wear at 1,000,000 counts, this value should be reduced to prevent a pump tube failure. Pump tubes wear out sooner when the sampled liquid contains a high percentage of suspended or abrasive solids. Pump tubes typically last 1,000,000 counts when pumping relatively clean liquids at normal temperatures.

Note

The importance of regular tubing replacement cannot be overstated. The key is to replace the tube before failure, not after. When a pump tube ruptures, grit and other abrasive debris can enter the pump housing. Over time, this abrasive material may degrade the sample collection performance.

Failure to maintain the pump tube may result in permanent damage to the sampler. Check the condition of the pump tube regularly and if the tube shows signs of fatigue or wear, replace it immediately. A properly maintained sampler will provide years of reliable service that is expected of a Teledyne Isco Sampler.

3.3.11 Program Lock

Select this option to turn the Program Lock feature on or off, and to change the password. When this security feature is enabled, the sampler requires a numeric password before a user can configure, program, calibrate, run a program, or grab a sample.

SELECT OPTION: (<--->)
PROGRAM LOCK

USE PROGRAM LOCK?
YES NO

CHANGE PASSWORD?
YES NO

ENTER NEW PASSWORD:

REENTER PASSWORD:

1. Select the PROGRAM LOCK option and press Enter.
2. Select YES to turn on the Program Lock feature or NO to turn it off, then press Enter. If YES, the CHANGE PASSWORD option is displayed.
3. Select YES to change the password or NO to exit and leave the password unchanged.
4. If YES was selected, enter a numeric password, up to four characters, then press Enter.
5. Re-enter the password to confirm it. The sampler will alert you if the passwords do not match and allow you to enter them again.

Should you forget the password, contact Teledyne Isco's Customer Service department for assistance.

3.3.12 Language

Select this option to change the display language and display units for length measurements.

```
SELECT OPTION: (<-->)
LANGUAGE
```

```
SELECT LANGUAGE (<-->)
ENGLISH
```

1. Select the LANGUAGE option and press Enter.
2. Press the Next or Previous buttons to scroll through the options. Press the Enter button when the desired option is displayed. If you select a language other than English, the sampler automatically displays length or distance units as meters and returns to the SELECT OPTION <--> screen. If you select English, the sampler displays length or distance units as feet and returns to the SELECT OPTION <--> screen.

3.3.13 System IDs

Select this option to view the system IDs. This function reports the unique ID for the sampler, and its hardware and software versions. These IDs are factory set.

```
SELECT OPTION: (<-->)
SYSTEM IDs
```

```
4700 SAMPLER
ID: _____
```

```
HARDWARE: ____
SOFTWARE:  _ _
```

1. Select the SYSTEM IDs option and press Enter.
2. The first line lists the Model Number. The second line lists the unique ID for the sampler. Press Enter to continue.
3. This screen lists the version numbers of the installed hardware and software. Press the Enter button to return to the SELECT OPTION <--> screen.

3.3.14 Run Diagnostics

Select this option to enter the sampler diagnostics mode to test the sampler memory, display, keypad, pump, distributor, and various inputs and outputs.

For more information about this service-related feature, refer to section 5.2.

3.3.15 Exit Configuration

Select this option to exit the configuration mode and return to the Main Menu screen.

3.4 Sampling Program Overview

The sampling program controls how often *sample events* occur and what should take place at each event. A sample event may happen when:

- you start a flow paced program that is programmed to Sample at Start (section 3.3.6).
- a time paced program reaches the First Sample time and date,
- your programmed time interval has elapsed,
- your programmed number of flow pulses has been reached, or
- a disabled sampler becomes enabled (section 3.3.7).

At each event, the sampler:

1. Resets the programmed flow or time pacing interval.
2. Moves the distributor arm over the next bottle. (This step does not occur for samplers configured with the 20 liter composite bottle.)
3. Rinses the suction line (see section 3.3.5).
4. Sends a three-second event mark signal that begins at forward pumping. The sampler deposits the programmed sample volume into the bottle.

If programmed to deposit a sample volume in more than one bottle, the sampler:

- a. Moves the distributor arm over the next bottle.
 - b. Deposits the programmed sample volume into the bottle.
 - c. Repeats steps 4a and 4b until the programmed number of bottles per event is reached.
5. Rinses the suction line (see section 3.3.5).

There are four categories of sampling program instructions that control the above actions in an event:

- **Pacing** instructions define what controls the sample collection interval and its frequency.
- **Distribution** instructions define where the collected liquid sample is placed.
Single-bottle samplers can only distribute the sample to the composite bottle therefore skip the steps in this category.
- **Volume** instructions define how much liquid is collected at each interval, and the total volume to collect.
- The **Start Time** tells the sampler when to begin operation.

These categories and their related programming screens are illustrated in Figure 3-3 for time paced sampling programs and Figure 3-4 for flow paced sampling programs. Each screen includes a section number that you can refer to should you need a detailed explanation of the step.

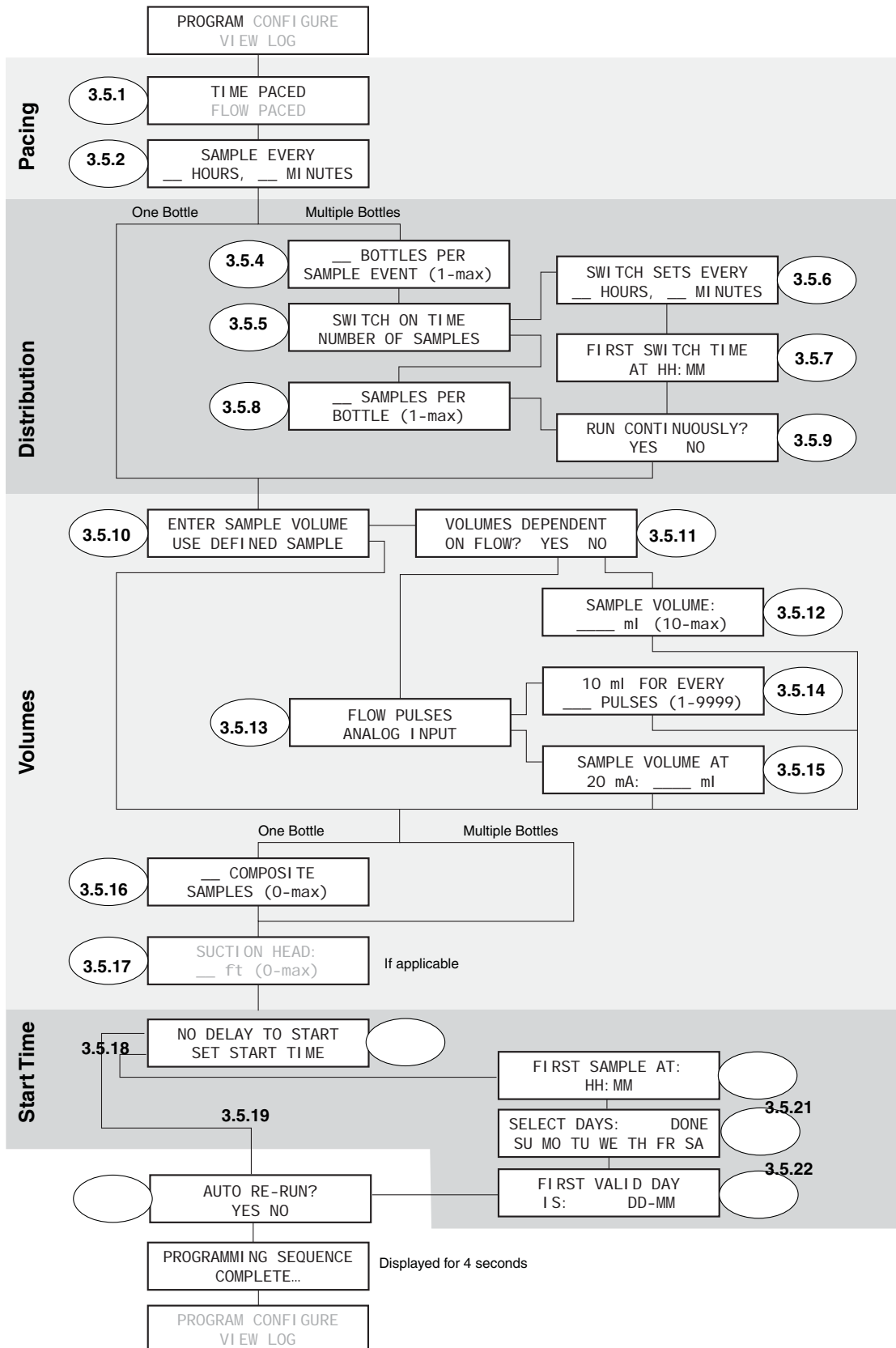

Figure 3-3 Time paced sampling program flow chart

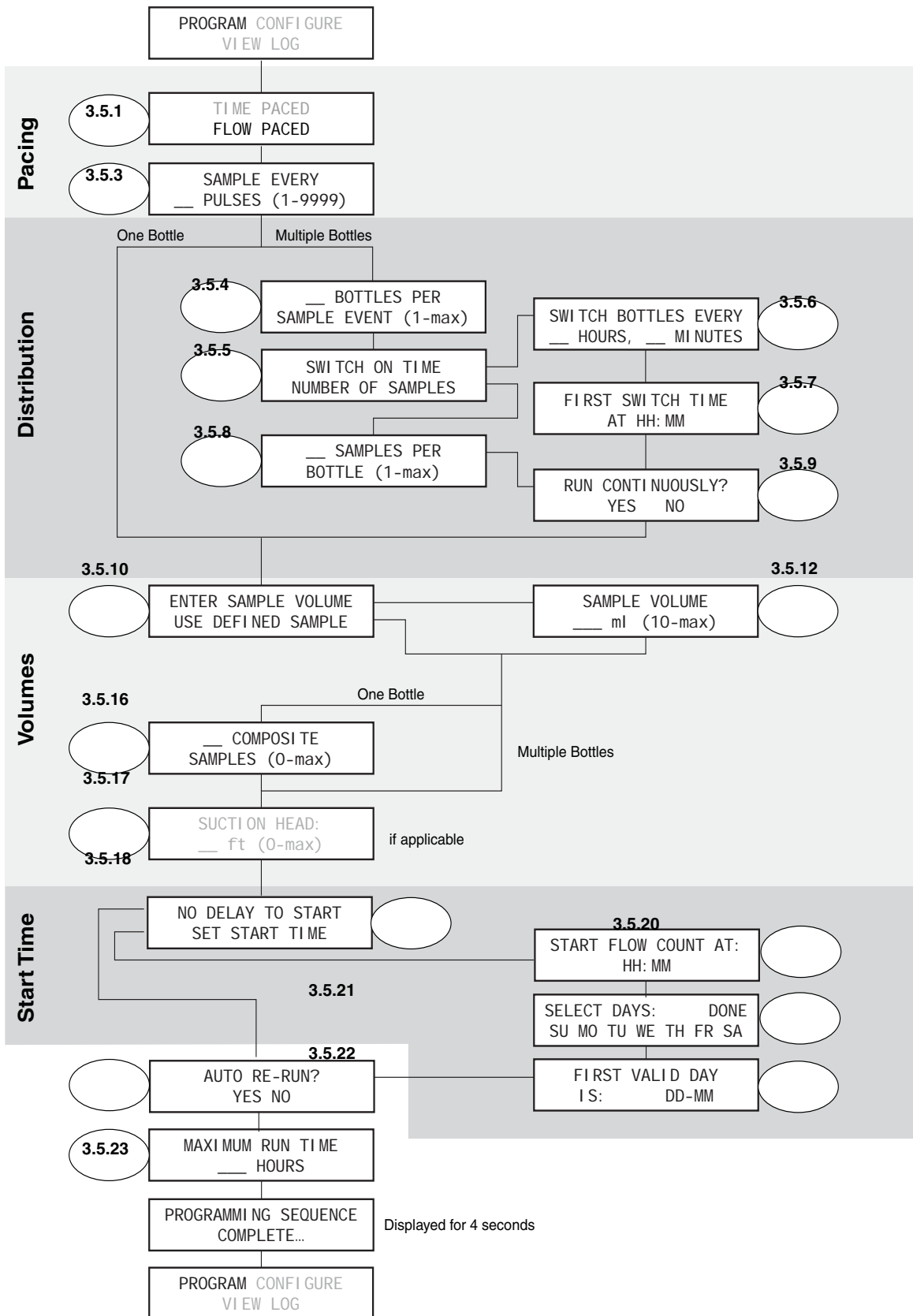

Figure 3-4 Flow paced sampling program flow chart

3.5 Programming Steps

To begin programming from the Main Menu screen, use the Next or Previous button to select PROGRAM. Press the Enter button to display the first programming screen. Refer to Figures 3-3 or 3-4 and the following descriptions.

CAUTION

This sampler has a high performance pump. As with all such pumps, it relies upon liquid to cool working components. If the sampler is programmed to pump in the absence of liquid in excess of 5 minutes, excessive heat buildup may damage the paddles, rollers, and housing. Ensure that the liquid inlet is completely immersed.

3.5.1 Pacing

There are two pacing methods for sampling programs:

- **Time paced** sampling programs use the sampler's internal clock to collect samples at a constant time interval. When you program the sampler for time pacing, the sampler will prompt you to enter the time between sample events in hours and minutes.
- **Flow paced** sampling programs require an electronic signal from a flow measurement device. This electronic signal is typically a pulse that indicates some user-programmed volume interval has passed through the flow channel. Because each pulse represents a volume interval, flow pacing rates are proportional to the volume of water flowing through the channel. This is sometimes called "Constant Volume Variable Time (CVVT) sampling." When you program the sampler for flow pacing, the sampler will prompt you to enter the number of pulses to count before collecting a sample.

Note

All Isco flow meters provide a compatible flow pulse. Non-Isco flow measurement devices may be used to pace the sampler. Refer to section 2.8, *Connecting the Sampler to External Devices*, for more details.

Use the Next or Previous buttons to select the time or flow option, then press the Enter button.

3.5.2 Sample Every __ Hours, __ Minutes

Time Paced Only – Use the Number buttons to enter the time interval in hours and minutes. The sampler collects a sample each time this interval elapses while the program is running.

3.5.3 Sample Every __ Pulses

Flow Paced Only – Use the Number buttons to enter the flow interval as a number of pulses. While the program is running the sampler counts the flow pulses until this number is reached. At this time the sampler collects a sample and resets the interval to begin counting again.

The volume that each flow pulse represents is determined by the flow measurement device. With some instruments this volume is user-defined; others use a fixed volume. Refer to the instruction manual of the flow measurement device.

For example, consider an Isco 4250 Flow Meter programmed to send a flow pulse every 100 gallons. If you are required to collect a sample every 10,000 gallons, you would enter 100 flow pulses.

$$10000 \text{ gallons} \div 100 \text{ gallons per pulse} = 100 \text{ pulses}$$

If the flow measurement device sends flow rate data via a 4-20 mA current loop instead of flow pulses, the sampler converts this analog current to flow pulses representative of a volume. The sampler assumes that the current is linear from 4 mA at zero flow to 20 mA at the full-scale flow rate. This factory-calibrated conversion produces one pulse every 12 seconds (5 flow pulses per minute) at 20 mA and scales the pulse intervals until there are no pulses at 4 mA. See Table 3-2 for flow pulse intervals at various currents.

Table 3-2 Flow Pulse Intervals at Various Input Currents		
Input Current (mA)	Seconds Between Pulses	% of Full Scale Flow Rate
4	∞ (no pulses)	0
5	192	6.25
6	96	12.5
7	64	18.75
8	48	25
9	38.4	31.25
10	32	37.5
11	27.4	43.75
12	24	50
13	21.3	56.25
14	19.2	62.5
15	17.4	68.75
16	16	75
17	14.8	81.25
18	13.7	87.5
19	12.7	93.75
20	12	100

To calculate the number of flow pulses to enter in this sampler programming screen, follow the steps below.

1. Determine the full scale flow rate (Q_{max}) that is represented by the flow measurement device at 20 mA.
2. Divide Q_{max} by a time factor (F_{time}) to find the volume represented by a single flow pulse. The time factor you choose is determined time unit on which the flow rate is based:

Time Unit	F_{time} Factor
seconds (cfs, m ³ s, <i>etc.</i>)	0.08333
minutes (gpm, l/m, <i>etc.</i>)	5
hours (gph, m ³ h, <i>etc.</i>)	300
days (mgd, m ³ d, <i>etc.</i>)	7200

3. Divide the sample interval (I_{samp}) by the result of step 2. The final value is the number of pulses you enter in this screen.

The steps can be summarized in the equation below.

$$I_{samp} \div (Q_{max} \div K_{time}) = \text{Number of pulses}$$

Note

The equation requires similar units for Q_{max} and I_{samp} . That is, the volume and flow rate units must use the same basic unit (cubic feet and cubic feet per second, gallons and gallons per minute, *etc.*). If they are dissimilar, convert the units before applying them to the equation.

Example 1 – Consider a flow meter programmed to output 20 mA at 1,000 liters per minute, the peak flow rate of the channel. If you are required to collect a sample every 10,000 liters, you would enter 50 flow pulses according the equation.

$$10000 \text{ liters} \div (1000 \text{ liters per minute} \div 5) = 50 \text{ pulses}$$

Example 2 – Consider a flow meter programmed to output 20 mA at 20 cubic feet per second. If you are required to collect a sample every 2400 cubic feet, you would enter 10 flow pulses according the equation.

$$2400 \text{ cubic feet} \div (20 \text{ cubic feet per second} \div 0.08333) = 10 \text{ pulses}$$

Example 3 – Consider a flow meter programmed to output 20 mA at 8 mgd (million gallons per day) and you are required to collect a sample every 10,000 gallons. Because the base units are dissimilar, you first must convert either the flow rate to gallons per day or your sample interval to millions of gallons. (The example below shows the flow rate converted to gallons per day.) After completing the equation you would enter 9 flow pulses.

$$10000 \text{ gallons} \div (8000000 \text{ gallons per day} \div 7200) = 9 \text{ pulses}$$

3.5.4 __ Bottles per Sample Event

Multiple Bottles Only – The sampler places a sample volume in one bottle or sets of bottles at each sample event. Use this screen to enter the number of bottles to repeat the sample volume at each sample event. The effect of this number is illustrated below.

Distribution scheme with one bottle per sample event. *Sample events are numbered.*

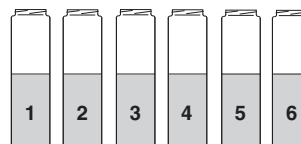

Distribution scheme with two bottles per sample event.

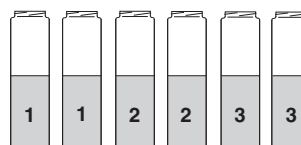

Distribution scheme with three bottles per sample event.



3.5.5 Switch on Time or Number of Samples

Flow Paced, Multiple Bottles Only – The sampler can switch bottles at regular time intervals or switch after a specified number of samples. Use the Next or Previous buttons to select your choice.

3.5.6 Switch Sets Every __ Hours, __ Minutes

Flow Paced, Multiple Bottles Only – If you selected Switch on Time (section 3.5.5), use the Number buttons to enter the desired time interval for bottle or bottle set switches.

3.5.7 First Switch Time

Flow Paced, Multiple Bottles Only – If you are switching bottles by time intervals, use this screen to specify the first switch time. All other bottle or bottle set switches will be relative to this time. Press the Number buttons to enter the time of day in 24-hour format.

3.5.8 Samples per Bottle

Multiple Bottles Only – The sampler places a sample volume from one or more sample events in a bottle. Use this screen to enter the number of sample volumes to place in a bottle. The effect of this number is illustrated below.

Distribution scheme with one sample per bottle. *Sample events are numbered.*

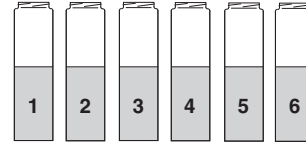

Distribution scheme with two samples per bottle.

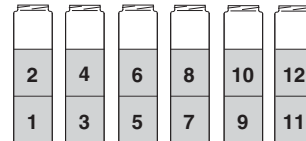

Distribution scheme with three samples per bottle.

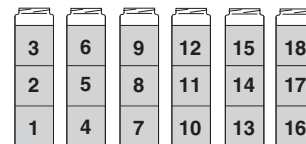

This Samples per Bottle feature can be combined with the Bottles per Sample Event (section 3.5.4) to build more complex distribution schemes, sometimes known as *multiple bottle compositing*. An example is illustrated below.

Distribution scheme with three bottles per sample event and three samples per bottle. *Sample events are numbered.*



3.5.9 Run Continuously?

Multiple Bottles Only – Sample programs can run indefinitely by selecting YES at the RUN CONTINUOUSLY? screen. Continuous sampling resets the distribution when the distribution sequence is complete. That is, when the last bottle/set is reached, the next bottle/set is the first bottle/set.

In this mode, the sampler assumes that any filled bottles are replaced and ready to receive samples while the program is running, thus the pacing interval is never interrupted.

If you select NO, the sampler will run until it completes the distribution sequence, at which time it stops the program and reports PROGRAM DONE. The sampler will wait in this state until the bottles have been emptied and the program is restarted.

If your sampler is configured for composite sampling, refer to section 3.5.16 for instructions on continuous sampling.

**3.5.10 Enter Sample Volume
Use Defined Sample**

At this screen you have the option to enter a sample volume (factory default is 200 ml) or use a manually defined sample volume based on pump counts.

If you choose ENTER SAMPLE VOLUME, the programming displays will step through a series of screens that let you enter the sample volume. When running a program, the sampler will use these settings and vary the sample collection cycle to deliver the entered sample volume at any suction head height.

To view or change the entered sample volume, use the Next or Previous button to select ENTER SAMPLE VOLUME. Then, press the Enter button to advance to the next screen (section 3.5.12).

If you choose USE DEFINED SAMPLE, the sample collection cycle is always a fixed number of pump counts. This option can be beneficial when collecting samples from pressurized lines whenever exceptional sampling conditions make it difficult to detect liquids and collect accurate sample volumes. To USE DEFINED SAMPLE, press the Next or Previous button to select this option. Then, press the Enter button.

Note

When using defined samples, be sure to DEFINE SAMPLE using the Calibrate button. See the example “*Defining the Sample Volume*” on page 3-23.

Note

Selecting USE DEFINED SAMPLE will disable bottle overflow detection.

3.5.11 Volumes Dependent on Flow?

Time Paced Only – The sampler can vary the sample volume according to an input from an external flow rate measurement device, or use a fixed volume at every time interval. To use variable sample volumes, sometimes called *Constant Time Variable Volume* (CTVV) sampling, select YES. To use fixed sample volumes, select NO.

3.5.12 Sample Volume __ ml

This screen displays the defined sample volume. Use the Number buttons to enter the sample volume. Press the Enter button to accept the displayed value.

3.5.13 Flow Pulses, Analog Input

Time Paced Only – If you are collecting sample volumes dependent on flow (section 3.5.11), select which type of flow rate input is provided by the external flow measurement device (see section 2.8).

3.5.14 10 ml for Every __ Pulses

Time Paced Only – If you selected FLOW PULSES to determine the sample volume (section 3.5.13), use the Number buttons to enter the number of pulses required to deliver 10 ml of liquid. This value establishes the ratio of flow rate to the sample volume at each event.

For example, consider a time-paced sampler programmed to collect a sample every hour and you entered “10 ml for every 5 pulses.” If the sampler records 100 pulses over the hour, it will collect a 200 ml sample (100 pulses ÷ 5 pulses × 10 ml = 200 ml).

**3.5.15 Sample Volume at
20 mA: __ ml**

Time Paced Only – If you selected ANALOG INPUT to determine the sample volume (section 3.5.13), use the Number buttons to enter the sample volume to be collected at the maximum flow rate, 20 mA. The sampler will linearly scale sample volumes at flow rates less than maximum.

3.5.16 __ Composite Samples

Single Bottle Only – Use the Number buttons to type the number of composite samples to take. Press the Enter button to accept the value.

The sampler calculates the maximum possible number of samples by dividing the configured bottle size (section 3.3.2) by the size of each sample volume (section 3.5.12).

3.5.17 Suction Head

This screen is displayed only if the liquid detector is turned off (section 3.3.5). Use the Number buttons to type the suction head height. Press the Enter button to accept the value.

Suction head height is the vertical distance from the liquid surface to the pump inlet. To measure the suction head height, refer to Figure 3-5.

For most applications, Teledyne Isco recommends that you turn on the liquid detector (section 3.3.5). The sampler will automatically calculate the suction head height, typically resulting in more accurate and repeatable sample volumes.

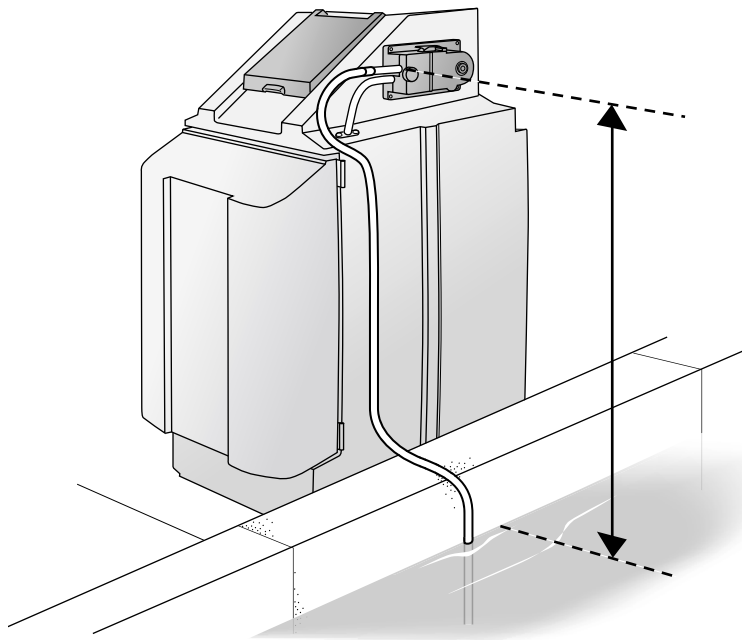

Figure 3-5 Suction Head Height

Applications that collect samples from a pressurized line are an exception. Teledyne Isco offers a pressurized line option for the sampler. Contact the factory for more information.

When using Teledyne Isco's pressurized line option, disable liquid detection and enter "1" at the suction head screen. Sample volumes should use the DEFINED SAMPLE option. Refer to section 3.5.10.

3.5.18 No Delay to Start Set Start Time

At this screen you have the option to start the sampling program immediately when you press the green Run Program button, or delay the sampling program until user-defined start time is met.

To program the sampler to start immediately, use the Next and Previous buttons to select the NO DELAY TO START option and press the Enter button.

To set a start time and date, use the Next and Previous buttons to select the SET START TIME option. Then, press the Enter button to advance to the next screen (section 3.5.20).

<input checked="" type="checkbox"/> Note

If you enter a "First Sample At" or Start Flow Count At" month less than the current month, the sampler interprets the start time as *next year's* date.

3.5.19 First Sample At:

Time Paced Only – Use the Number buttons to set the start time hours. Press the Enter button to accept the value and advance to the minutes. Repeat to complete the minutes, date, and month.

3.5.20 Start Flow Count At:

Flow Paced Only – Use the Number buttons to set the start time hours. Press the Enter button to accept the value and advance to the minutes. After setting the start time minutes, press Enter to accept the value and advance to the next screen.

3.5.21 Select Days:

Use the arrow buttons to select the desired days of the week, pressing Enter to activate or deactivate selections. When selections are completed, select DONE, then press Enter to advance to the next screen.

3.5.22 First Valid Day

Use the number keys to set the program starting day and month, pressing Enter to accept the values.

3.5.23 Maximum Run Time __ Hours

Flow Paced Only – Use the Number buttons to set the maximum run time. The sampler will stop the running sampling program when this time has elapsed.

This feature is useful for applications that require the collection of a total sample volume proportional to the flow volume over a specific duration. An example of this would be a flow-weighted composite sample representative of the total daily flow volume (24 hours). If your application does not limit the sample collection to a specific duration, enter zero.

3.6 Programming Examples

Pages 3-23 through 3-28 provide programming examples.

- Defining the Sample Volume
- Time Paced Sampling Program
- Flow Paced Sampling Program

- Flow-proportional Constant Time Variable Volume Program

Example: Defining the Sample Volume

If you have programmed the sampler to USE DEFINED SAMPLE (section 3.5.10), follow the steps in this example to define the volume using pump counts.

1. At the Main Menu display, press the Calibrate button.

```
PROGRAM  CONFIGURE
VIEW LOG
```

2. The sampler displays the Calibrate Volume or Define Sample option screen. Use the Next or Previous buttons to select DEFINE SAMPLE. Then press the Enter button.

```
CALIBRATE VOLUME
DEFINE SAMPLE
```

3. The sampler displays the pre-purge screen to define number of counts needed to purge the suction line. To simply review the pump count values, press the Next button to advance through the screens. To change the pump counts, use the Number buttons to type the pre-purge counts. Or, press and hold the "1" button to reset the count to zero and start the pump in reverse to purge the line. Hold the 1 button until the line is sufficiently purged.

```
___ COUNT PRE-PURGE
HOLD '1' TO PURGE
```

When you release the 1 button the sampler reports the number of purge counts that elapsed while you held down the button. Press the Enter button to save the value and continue.

4. The sampler displays a screen to define number of counts needed to deliver the desired volume. Use the Number buttons to type the sample counts. Or, press and hold the "3" button to reset the count to zero and start the pump. The pump will draw the liquid through the suction line and pump, then

deposit it into the bottle. To measure the delivered volume, you can replace the bottle with a graduated cylinder for this step.

```
___ COUNT SAMPLE
HOLD '3' TO PUMP
```

Release the button when the desired volume has been collected. Press the Enter button to save the value and continue.

5. The sampler displays the post-purge screen to define number of counts needed to purge the suction line. Use the Number buttons to type the post-purge counts. Or, press and hold the "1" button to reset the count to zero and start the pump in reverse to purge the line. Hold the 1 button until the line is sufficiently purged.

```
___ COUNT POSTPURGE
HOLD '1' TO PURGE
```

When you release the 1 button the sampler reports the number of purge counts that elapsed while you held down the button. Press the Enter button to save the value and finish defining the sample.

```
___ COUNT POSTPURGE
```

```
PROGRAM  CONFIGURE
VIEW LOG
```

Repeat these steps as needed until the desired sample volume is collected.

You may find it easiest to press and hold the 1 and 3 buttons the first time through to roughly define the sample volume. Then, repeat these steps and enter the pump count values to finely adjust the sample volume. You can check the defined sample volume using the Grab Sample feature (section 4.4) and selecting USE DEFINED SAMPLE.

Example: Time Paced Sampling Program

This example shows how to program the sampler to collect a 500 ml sample every hour for twenty-four hours. The sampler will place each discrete sample in a separate bottle. The sampling program should take the first sample at 8:00 AM on the date you select.

This program example assumes that the sampler has been configured with 24 bottles (sections 2.4.2 and 3.3.2) and the liquid detector is turned on. It also assumes that the current time is before 8:00 AM.

1. Begin programming by selecting the PROGRAM option from the Main Menu screen.

```
PROGRAM  CONFIGURE
VIEW LOG
```

2. The sampler displays the Time or Flow pacing option screen. Use the Next or Previous buttons to select TIME. Then press the Enter button.

```
TIME PACED
FLOW PACED
```

3. The sampler displays the pacing interval screen. Use the Number buttons to type the pacing interval in hours and minutes (1 hour, 0 minutes). Press the Enter button.

```
SAMPLE EVERY
__ HOURS, __ MINUTES
```

4. The sampler displays the Bottles Per Sample Event screen. Because our program requires one bottle for each sample event, type "1" using the Number button and press Enter.

```
__ BOTTLES PER
SAMPLE EVENT (1-max)
```

5. The sampler displays the Samples Per Bottle screen. Our program requires discrete samples in each bottle. Therefore, type "1" using the Number button and press Enter.

```
__ SAMPLES PER
BOTTLE (1-max)
```

6. The sampler displays the Run Continuously screen. Select NO to stop the sampling program after the last bottle.

```
RUN CONTINUOUSLY?
YES NO
```

7. The sampler displays the option to enter a sample volume or use the defined volume. Select ENTER SAMPLE VOLUME and press Enter.

```
ENTER SAMPLE VOLUME
USE DEFINED SAMPLE
```

8. The sampler displays the Volume Dependent On Flow screen. Select NO using the Next or Previous buttons and press Enter.

```
VOLUMES DEPENDENT
ON FLOW? YES NO
```

9. The sampler displays the Sample Volume input screen. Type "500" using the Number buttons and press Enter.

```
SAMPLE VOLUME:
__ ml (10-max)
```

10. The sampler displays the Start Time option screen. Select SET START TIME and press Enter.

```
NO DELAY TO START
SET START TIME
```

11. The sampler displays the First Sample At screen. Type the hours "08" using the Number buttons and press the Enter button. Type the minutes "00" and press Enter.

```
FIRST SAMPLE
AT: HH:MM
```

The clock start time lets you set the sampler to start the program at the same time on one or more desired days of the week, which are selected on the screen that follows.

12. The sampler displays the Select Days screen. The day or days when the program is set to run will be blinking. To activate a day, press an arrow key until the correct day is blinking and press Enter. To deactivate a day, press an arrow key until the day is selected, then press Enter. The day will stop blinking. When the days are set, press Enter once more to enter the values.

```
SELECT DAYS:  DONE
SU MO TU WE TH FR SA
```

Continued...

Time Paced Sampling Program, continued

13. The sampler displays the First Valid Day screen. Enter the calendar day for the program to begin running and press Enter.

FIRST VALID DAY
IS: DD-MM

14. The sampler displays the Programming Sequence Complete screen for four seconds, then advances to the Main Menu screen.

PROGRAMMING SEQUENCE
COMPLETE...

PROGRAM CONFIGURE
VIEW LOG

To run the sampling program, press the green Run Program button.

Example: Flow Paced Sampling Program

This example shows how to program the sampler to collect a 100 ml sample every 10,000 gallons of liquid that has passed the sampling point. The sampler will composite the samples in one of its two 10-liter bottles. The sampling program should begin counting the elapsed flow at midnight and run continuously.

Because the program runs continuously, the sampler will fill one bottle in a day, then fill the other bottle the next day. Daily, an operator would only need to exchange the completed bottle with an empty one and the program could run indefinitely. However, service intervals should be planned to replace worn pump tubes.

This example assumes that the sampler has been configured with 2 bottles (sections 2.4.4 and 3.3.2). It also assumes the flow meter connected to the sampler (sections 2.8) sends a flow pulse every 1,000 gallons.

1. Begin programming by selecting the PROGRAM option from the Main Menu screen.

```
PROGRAM  CONFIGURE
VIEW    LOG
```

2. The sampler displays the Time or Flow pacing option screen. Use the Next or Previous button to select FLOW PACED. Then press the Enter button.

```
TIME PACED
FLOW PACED
```

3. The sampler displays the pacing interval screen. Type "10" using the Number buttons. Given that the flow meter sends one flow pulse every 1,000 gallons, this would equate to a sample event every 10,000 gallons. Press the Enter button.

```
SAMPLE EVERY
___ PULSES (1-9999)
```

4. The sampler displays the Bottles Per Sample Event screen. Because our program requires one bottle for each sample event, type "1" using the Number button and press Enter.

```
___ BOTTLES PER
SAMPLE EVENT (1-max)
```

5. The sampler displays the Bottle Switch screen. Our program requires a bottle switch every 24 hours. Select SWITCH ON TIME and press Enter.

```
SWITCH ON TIME
NUMBER OF SAMPLES
```

6. The sampler displays the Switch Bottles Every screen. Type "24" for the hours and press Enter. Then, type "0" for the minutes and press Enter.

```
SWITCH BOTTLES EVERY
___ HOURS, ___ MINUTES
```

7. The sampler displays the First Switch Time screen. Our program must switch bottles at midnight. Type "0" for the hours and press Enter. Then, type "0" for the minutes and press Enter.

```
FIRST SWITCH TIME
AT HH: MM
```

8. The sampler displays the Run Continuously screen. Select YES.

```
RUN CONTINUOUSLY?
YES NO
```

9. The sampler displays the option to enter a sample volume or use the defined volume. Select ENTER SAMPLE VOLUME and press Enter.

```
ENTER SAMPLE VOLUME
USE DEFINED SAMPLE
```

10. The sampler displays the Sample Volume input screen. Type "100" using the Number buttons and press Enter.

```
SAMPLE VOLUME:
___ ml (10-max)
```

11. The sampler displays the Start Time option screen. Select SET START TIME and press Enter.

```
NO DELAY TO START
SET START TIME
```

Continued...

Flow Paced Sampling Program, continued

12. The sampler displays the Start Flow Count screen. Type "00" and press Enter, then type "00" and press Enter again (12:00 AM in 24-hour time format). Type the number for tomorrow's day and press Enter. Repeat for the current month.

START FLOW COUNT AT:
AT: HH:MM

13. The sampler displays the Maximum Run Time screen. Type "0" using the Number buttons.

MAXIMUM RUN TIME:
____ HOURS

14. The sampler displays the Programming Sequence Complete screen for four seconds, then advances to the Main Menu screen.

PROGRAMMING SEQUENCE
COMPLETE...

PROGRAM CONFIGURE
VIEW LOG

To run the sampling program, press the green Run Program button.

Example: Flow-proportional Constant Time Variable Volume Program

This example shows how to program the sampler to collect flow-proportional samples volumes at fixed time intervals. This program will collect a sample every 15 minutes. The sample volume will be dependent on a 4-20 mA flow rate input signal, which will collect a 100 ml sample at 1.0 m³s. The sampler will collect the samples over a 24-hour period and place them in a single bottle.

This example assumes that the sampler has been configured with a single 10 liter bottle (sections 2.4.5 and 3.3.2). It also assumes a 20 mA signal represents the channel's maximum flow rate of 1.0 m³s.

When determining the sample volume, you must consider the bottle capacity and the peak and average flow rates. Note that in this example flow at the maximum rate over a full day would yield a composite sample of 9600 ml — nearly the capacity of the bottle. However, flow rates at the collection point average 60% of the maximum which would result in a bottle roughly 60% full.

1. Begin programming by selecting the PROGRAM option from the Main Menu screen.

```
PROGRAM    CONFIGURE
VIEW LOG
```

2. The sampler displays the Time or Flow pacing option screen. Use the Next or Previous button to select TIME PACED. Then press the Enter button.

```
TIME PACED
FLOW PACED
```

3. The sampler displays the pacing interval screen. Use the Number buttons to type the pacing interval in hours and minutes (0 hours, 15 minutes). Press the Enter button.

```
SAMPLE EVERY
__ HOURS, __ MINUTES
```

4. The sampler displays the option to enter a sample volume or use the defined volume. Select ENTER SAMPLE VOLUME and press Enter.

```
ENTER SAMPLE VOLUME
USE DEFINED SAMPLE
```

5. The sampler displays the Volume Dependent On Flow screen. Select YES and press Enter.

```
VOLUMES DEPENDENT
ON FLOW?  YES  NO
```

6. The sampler displays a screen to select the flow rate input. Our sampler is connected to a 4-20 mA input signal. Therefore, select ANALOG INPUT and press Enter.

```
FLOW PULSES
ANALOG INPUT
```

7. The sampler displays a screen to set the sample volume to collect at the maximum flow rate. Type "100" and press Enter.

```
SAMPLE VOLUME AT
20 mA:  __ ml
```

8. The sampler displays the Composite Samples screen. To finish the program after a 24-hour period, type "96" (4 samples per hour × 24 hours) and press Enter.

```
__ COMPOSITE
SAMPLES (0-max)
```

9. The sampler displays the Start Time option screen. Select NO DELAY TO START and press Enter.

```
NO DELAY TO START
SET START TIME
```

10. The sampler displays the Programming Sequence Complete screen for four seconds, then advances to the Main Menu screen.

```
PROGRAMMING SEQUENCE
COMPLETE...
```

```
PROGRAM    CONFIGURE
VIEW LOG
```

To run the sampling program, press the green Run Program button.

Isco 4700

Refrigerated Sampler

Section 4 Operation

In this section...

- *Start a Sampler Program*
- *Pause or Stop a Running Program*, page 4-3
- *Post Sampling Activities*, page 4-3
- *View the Log*, page 4-3
- *Retrieve the Temperature Log*, page 4-5
- *Remove Sample Bottles*, page 4-7
- *Grab Samples*, page 4-8
- *Calibrate Sample Volumes*, page 4-8
- *Operate the Pump Manually*, page 4-9

This section describes how to operate the sampler. These instructions assume that the sampler has been correctly installed (section 2), configured, and programmed (section 3).

4.1 Start a Sampler Program

Before starting a program:

- Verify that the pump tube is in good condition. Refer to section 5.1.1.
- Place empty bottles in the rack or locating base.



To start the program from the Main Menu screen, press the green Run Program button.

If a sampler configured for multiple bottles was previously halted (see section 4.2), the sampler will display a start bottle option when you press the Run Program Button. This start bottle option only appears if no programming changes were made after halting the program.

ENTER START BOTTLE:
___ (1-max)

Using the Number buttons, enter the starting bottle. Then press the Enter button.

4.1.1 Start Time Delay

If the program is set for NO DELAY TO START (section 3.5.18), The sampler immediately begins to operate according to its Configure and Program settings.

If the program is set to use a start time, the sampler will wait for the specified time and date. During this delay, the display for time paced programs will show:

FIRST SAMPLE HH: MM DD-MON-YY

Or, for flow paced programs:

START FLOW COUNT AT: HH: MM DD-MON-YY
--

When the programmed start time and date matches the sampler's time and date the sampler program begins to run.

Should you press the green Run Program button and the programmed start time has already passed, the sampler program starts immediately.

4.1.2 The Run State

Because the sampler operation is fully automated, no user intervention is required. Should there be a need to check on the running program, you can view the sampler display. It always reports the current state or operation and the refrigerator temperature.

Typically, the display will count down to the next sample event. This countdown screen may alternate with other messages:

- If the sampler is disabled by an external device, the display will show PROGRAM DISABLED.
- If the sampler is currently taking a sample the display will show TAKING SAMPLE (number).
- If the sampler has encountered error conditions during the running program, the display will show ERRORS HAVE OCCURRED.
- If the sampler is programmed for time-switched bottles (section 3.5.5), the display will show NEXT BOTTLE AT: HH:MM:SS DD-MON-YY.
- If any programmed sampler operations are based on the sampler's internal clock, the display will show the current time and date.

4.1.3 Completed Program

When the program is complete, the display will show PROGRAM DONE and list the number of samples.

If the sampler encounters an error at any time during the running program, this display will alternate with an "ERRORS HAVE OCCURRED" message. Error messages are listed in Table 4-1.

4.2 Pause or Stop a Running Program

Press the red Stop button to pause a running program. The sampler will display:

RESUME IN MM:SS
VIEW LOG HALT

The top line of the display shows a five minute count down timer. If no buttons are pressed, the sampler program will automatically resume when the count reaches 0:00.

While paused, you can:

- View the log (see section 4.3.1)
- Collect a Grab Sample (see section 4.4)
- Halt the program — Press the Next or Previous buttons to select the HALT option. Then, press the Enter button.
- Resume the program — Press the Next or Previous buttons to select the RESUME IN M:SS option. Then, press the Enter button. Or, you can press the Stop button to exit the paused state and resume the program.

During the pause, you can reset the countdown timer to five minutes by pressing the Number, Next, or Previous buttons.

Note

While paused, the sampler skips sample events that would have occurred otherwise. These are reported in the Log as MISSED SAMPLES (number): PROGRAM PAUSED.

4.3 Post Sampling Activities

Post-sampling activities include:

- Viewing the Log (section 4.3.1)
- Retrieving the Refrigerator Temperature Log (section 4.3.2)
- Removing the sample bottles (section 4.3.4)

4.3.1 View the Log

The sampler records events during the running program and summarizes them in a log. This log is held in the sampler memory until the next program is started.

To view the log after the completion of a program, press the Stop or Enter button to return to the Main menu. Then, press the Next or Previous buttons to select the VIEW LOG option and press the Enter button. You can also view the log while a program is paused.

While viewing the log, you can:

- Step forward through the screens by pressing the Next or Enter buttons.
- Step backward by pressing the Previous button.
- Exit the log by pressing the Stop button.

COLLECTED
___ OF ___ SAMPLES

MISSED SAMPLES: ___
(error message)

PROGRAM STARTED
HH: MM DD-MON-YY

PROGRAM COMPLETED
HH: MM DD-MON-YY

PROGRAM HALTED
HH: MM DD-MON-YY

PROGRAM PAUSED
___ SAMPLES REMAIN

POWER LOST
HH: MM DD-MON-YY

REFRIG TEMP DATA:
AVERAGE: ___ C

LAST CALIBRATED
HH: MM DD-MON-YY

LAST PROGRAMMED
HH: MM DD-MON-YY

CLOCK SET AT
HH: MM DD-MON-YY

4700 SAMPLER
ID: _____

HARDWARE: ___
SOFTWARE: _._

TEXT TRANSLATION
REVISION: ___

WARNING:
CHANGE PUMP TUBE

The log generally contains the following information:

1. The log reports the number of successful samples out of the total number programmed.
2. If samples were not collected, the log reports the number of missed samples and the error message. If there are multiple reasons, this screen will be repeated for the other error messages. Error messages are described in Table 4-1.
3. The log reports the time and date the program was started.
4. If the program was allowed to finish, the log reports the time and date the program was completed.
5. If the program was halted before the programmed completion time, the log reports the time.
6. If you are viewing the log while the program is paused, the log displays the number of samples that remain.
7. If power was lost during the program, the log reports the time of the most recent power failure event and the time that power was restored.
8. The log reports the average refrigerator temperature and the most recent time of the minimum and maximum recorded temperatures.
9. The log reports the time and date of the last sample volume calibration (see section 4.5), or the last DEFINE SAMPLE (see example “*Defining the Sample Volume*” on page 3-23).
10. The log reports the last time the program was modified.
11. The log reports the last time the clock was set.
12. The log reports the unique ID for the sampler control panel. This identifier is assigned at the factory.
13. The log reports the hardware and software revision of the control panel.
14. If the sampler displays a language other than English, the translation revision is displayed.
15. If the pump tubing count is exceeded the log will display a warning. For more information on the pump tube warning see sections 3.3.10 and 5.1.2.

Table 4-1 4700 Errors	
Message	Description
NO LIQUID DETECTED	The sampler was unable to detect liquid.
NO MORE LIQUID	After the sampler detected liquid and while the sample was being taken, the liquid detector stopped detecting liquid.
NOT ENOUGH FLOW	Not enough flow was measured to produce the minimum sample volume while collecting flow-proportional sample volumes (CTVV).
POWER FAILED!	The power was interrupted at the sample event time.
USER STOPPED PUMP	The Stop button was pressed during the sample event.
PROGRAM PAUSED	The program was paused at the time of the sample event.
PUMP FAILURE	The pump did not operate correctly. The sampler reports this error when some obstruction has stopped the pump rotor from turning, or when the pump band is open.
PROGRAM HALTED	The program was halted.
PROBABLE OVERFLOW	The sampler did not deliver the sample because it would have over-filled the bottle.

4.3.2 Retrieve the Temperature Log

The log presents a summary that lists the average, minimum and maximum temperatures from the last program. Should more complete temperature data be required, the sampler can provide a detailed report containing temperature readings at one-minute intervals. This report requires a connection to a personal computer.

To connect the sampler to a computer, use the optional 3.8 m (12.5 ft) RS-232 serial communication cable, 69-4704-042 (Figure 4-1). This cable connects to the DB9-pin serial port connection on a computer. Connections to a computer without the DB9-pin serial port will require a user-supplied USB to serial port adapter.

To collect the detailed temperature data:

1. Connect the computer to the sampler's external device connector with cable 69-4704-042.
2. Configure your communications software (HyperTerminal, for example) for:
 - a baud rate no higher than 38,400
 - 8 data bits
 - no parity
 - 1 stop bit
 - No flow control
 - Auto Detect or VT100 terminal emulation.

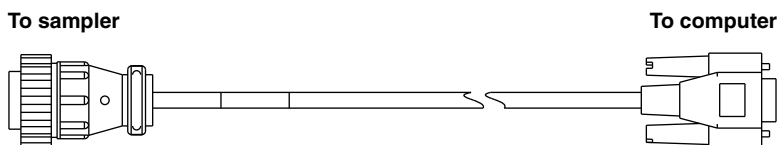

Figure 4-1 4700 Sampler to RS-232 serial communication cable

```
4700 Sampler, Model , 4700, ID, 1158325658,  
Current Time, 38980.62200,  
Run Time, 28126.00000,  
First Sample Time, 38978.55000,  
38980.61250, 1.8*,  
38980.61319, 2.1,  
38980.61389, 2.4,  
38980.61458, 2.6,  
38980.61528, 2.9,  
38980.61597, 3.0,  
38980.61667, 2.6,  
38980.61736, 2.0,  
38980.61806, 1.8,  
38980.61875, 2.0,  
38980.61944, 2.3,  
38980.62014, 2.6,  
38980.62083, 2.8,  
38980.62153, 3.0,  
38980.62222, 2.5
```

Figure 4-2 Sample temperature report

3. Using your communications software, connect to the sampler. Repeatedly type “?” (Shift + ?) using the computer keyboard until the sampler returns its banner string. The banner string lists the model number and unique ID of the sampler.
A “>” prompt will appear on the screen when it is ready to accept commands.
4. From the computer, type “DATA” and press the Enter keyboard button.

The sampler sends the detailed temperature report in a Comma-separated Value (CSV) format. This CSV report can be captured and saved using your communications software.

Figure 4-2 shows a sample report. The first line contains the banner string which identifies the sampler. The next three lines report the current time, run time, and first sample time. The remainder of the report are lines that include a time stamp and temperature reading. If a temperature reading is followed by an asterisk (*), an error condition existed at that time.

All times are reported as serial values, which are easily converted to dates and times by spreadsheet programs. The numbers to the left the decimal point are the number of days since January 1, 1900. The numbers to the right are fractional days which can be converted to hours, minutes, and seconds.

4.3.3 Sampling Reports

To retrieve a report of the sampler's program settings, type **SETTINGS<CR>**.

The sampler records the sample and bottle number at the time of each sample event. A sampling results report can be obtained by typing **RESULTS<CR>**. The RESULTS report contains data from the most recently run program only.

For a report containing both settings and results, type **REPORT<CR>**.

4.3.4 Remove Sample Bottles

After the program is complete, the bottles can be removed and prepared for the laboratory. Gain access to the bottles by releasing the door latch and swinging the door open. The bottles can then be removed from the rack or locating base. Push the distributor arm out of the way if needed.

If you are using the 24-bottle rack, you can slide it out to easily reach the bottles in the back. When sliding the rack out, observe the rack guides (Figure 4-3). The back two guides run along the top of the rack to prevent the rack from tipping forward. Do not pull the rack out beyond these guide pins unless you are securely holding the rack.

Removed bottles should be capped and labeled according to the protocol established by your laboratory.

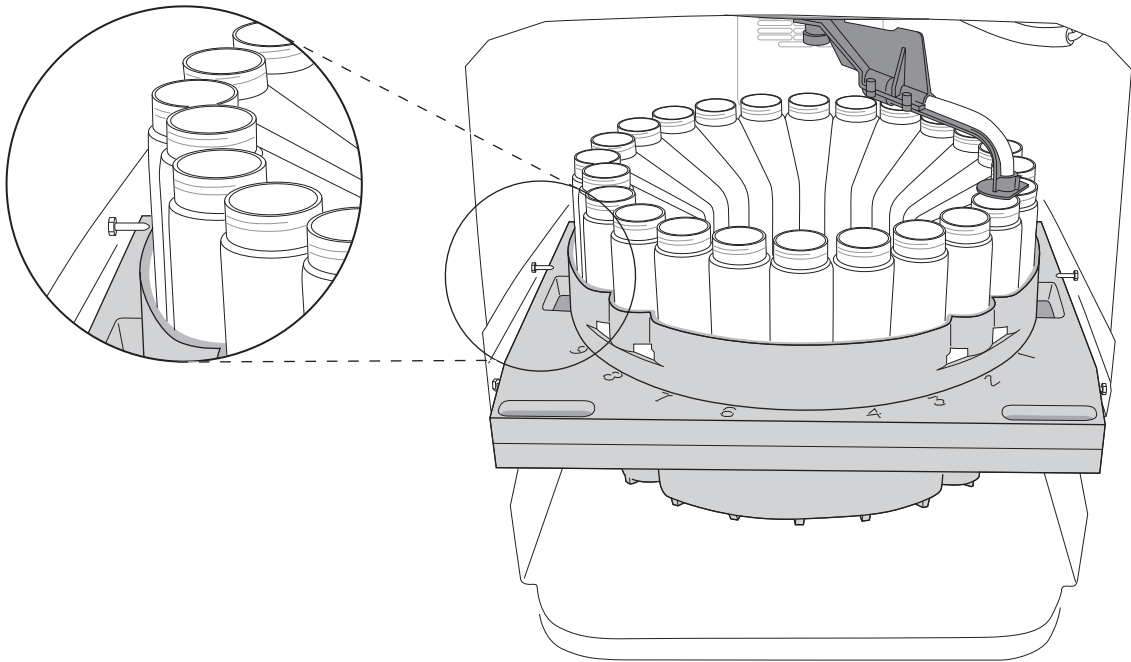

Figure 4-3 Sliding the 24-bottle rack out

4.4 Grab Samples

Grab samples let you take a single sample on demand and collecting it in an external container. You can collect a grab sample while the sampler is running a program, paused, or at the Main Menu screen.

To collect a grab sample:

1. Press the GRAB SAMPLE button.
2. The sampler asks how much liquid to collect. To collect a sample volume defined by pump counts, select USE DEFINED SAMPLE. To collect a different volume, select the ENTER SAMPLE VOLUME, then use the Number buttons to enter the desired grab sample volume.

Note

If you selected the USE DEFINED SAMPLE option, the sampler will collect the sample volume according to the DEFINED SAMPLE calibration setting. For more information on this feature see the example “Defining the Sample Volume” on page 3-23.

3. The sampler displays GRAB SAMPLE PRESS (enter) WHEN READY and waits for you to prepare to collect a grab sample. Pull the lower pump tube from the bulkhead fitting. Hold the end of the tube over a container. Press the Enter button when you are ready.
4. The sampler goes through a complete sample collection cycle and deposits the requested amount of liquid in the container.
5. Return the pump tube to the bulkhead fitting.

Note

If a grab sample is taken while a program is running, it is not counted as part of the number of samples.

4.5 Calibrate Sample Volumes

The sampler can deliver sample volumes repeatable to ± 5 ml or $\pm 5\%$ of the average volume in a set. For accurate sample volumes, the sampler uses the suction line length (section 3.3.4) to generate pump tables. The pump tables along with the liquid detector are used to determine the suction head height and measure the liquid volume. By calculating the suction head, the delivered volumes are not affected by varying liquid levels.

Note

Incorrect suction line values, disabling the liquid detector, and worn pump tubes may adversely affect the sample volume accuracy.

Calibrating the sampler can enhance sample volume accuracy. To calibrate sample volumes, follow the steps below. These steps assume that the sampler has been correctly installed (section 2) and the suction line has been cut and its length entered in the sampler configuration (section 3.3.4). These steps also require a graduated cylinder to measure the delivered sample volume.

 **Note**

Teledyne Isco offers a 1000 ml graduated cylinder. Order part number 299-0020-00.

To calibrate the sample volume:

1. At the Main Menu, press the Calibrate button.
2. Select the CALIBRATE VOLUME option and press Enter.
3. Pull the lower pump tube from the bulkhead fitting. Hold the end of the tube over the graduated cylinder. Press the Enter button when you are ready.
4. Hold the graduated cylinder while the sampler collects the sample.
5. Measure the sample volume collected in the graduated cylinder and enter it in the VOLUME DELIVERED screen.
6. If there is a large difference between the expected volume and your entered volume, the sampler asks you to confirm the entered volume. If the volume you entered is correct, select YES. Otherwise, select NO and re-enter the measured sample volume.
7. Return the pump tube to the bulkhead fitting.

CALIBRATE VOLUME
DEFINE SAMPLE

CALIBRATE VOLUME:
PRESS ↵ WHEN READY!

TAKING ___ ml
CALIBRATE SAMPLE

VOLUME DELIVERED:
___ ml

___!
SURE? ARE YOU YES NO

For small volumes, repeat the calibration to ensure that the calibration is averaged and not unduly influenced by normal random variations.

An alternative method using manually defined sample volumes may be helpful for difficult applications. See section 3.5.10.

4.6 Operate the Pump Manually

The sampler pump can be operated manually from the Main Menu display.

To operate the pump:

1. Press the “1” Number button to prepare the pump for reverse operation (line purge).

Or, press the “3” Number button to prepare the pump for forward operation (sample).

2. Press the Enter button to start the pump in the selected direction.
3. Press the Stop button to stop the pump and return to the Main Menu.

PRESS ↵ TO
PUMP REVERSE

PRESS ↵ TO
PUMP FORWARD

Isco 4700 Refrigerated Sampler

Section 5 Maintenance

In this section...

- *Periodic Maintenance Checklist*
- *Sampler Diagnostics*, page 5-6
- *Temperature Verification*, page 5-13

This section describes how to maintain and troubleshoot your sampler. If you think your sampler requires repair, or if you have questions concerning its operation or maintenance, contact your authorized Isco service facility or Teledyne Isco's Technical Service Department:

Phone: (800) 228-4373 (USA, Canada, Mexico)

(402) 464-0231 (international)

FAX: (402) 465-3001

E-mail: IscoService@teledyne.com

5.1 Periodic Maintenance Checklist

Before each use:

- Inspect the pump. Service as necessary.
- Inspect the pump housing and rollers.
- Clean or replace the wetted parts (bottles, suction line, strainer, pump tube, and discharge tube).
- Clean the sampler as necessary.

5.1.1 Pump Inspection

Inspect the pump before each use. Inspections are especially important when pumping large sample volumes over long distances or when the sample liquid contains a high percentage of suspended or abrasive solids. Pumps in need of service might experience performance problems such as:

- Faulty liquid detection
- Inaccurate sample volumes
- The sampler will not pump any liquid
- Pump jams.

To inspect the pump:

1. Press the On/Off button to place the sampler controller in the Standby state. This ensures that the sampler will not attempt to operate the pump.

 **WARNING**

The sampler has a safety interlock that prevents the pump from operating when the pump housing band is open. **DO NOT** tamper with the pump housing and band. The pump is extremely powerful. The pump can injure you severely if the sampler activates the pump while you are working on it. Place the sampler controller in the Standby state before opening the pump housing.

2. Refer to Figure 5-1. Release the latch (H) securing the metal pump housing band (K).
3. Swing the pump housing band away from the pump housing.
4. Inspect the following:
 - a. **Pump tube** – Look for excessive wear caused by the pump rollers and for cracks along the sides of the tube. Cracks might not be apparent unless you flex or squeeze the tubing. If cracks or excessive wear are evident, replace the pump tube (Section 5.1.2).

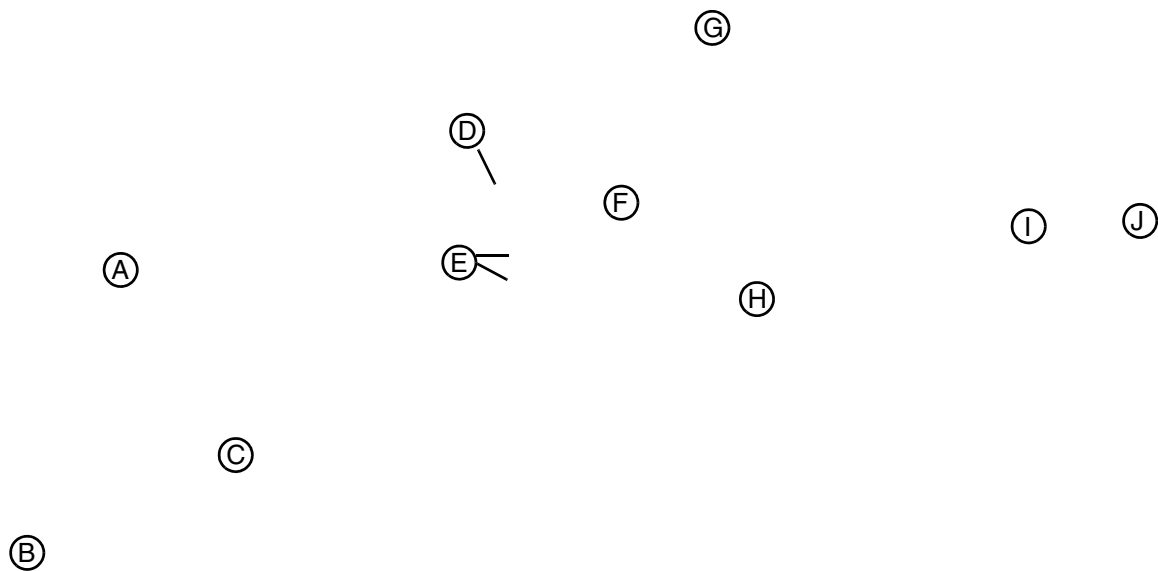

Figure 5-1 4700 Pump

- | | |
|----------------------|--------------------------|
| A. Pump Tube | F. Liquid Detector Cover |
| B. Bulkhead Fitting | G. Latch |
| C. Tubing Coupler | H. Knob |
| D. Alignment Notches | I. Pump Housing |
| E. Alignment Collars | J. Pump Housing Band |

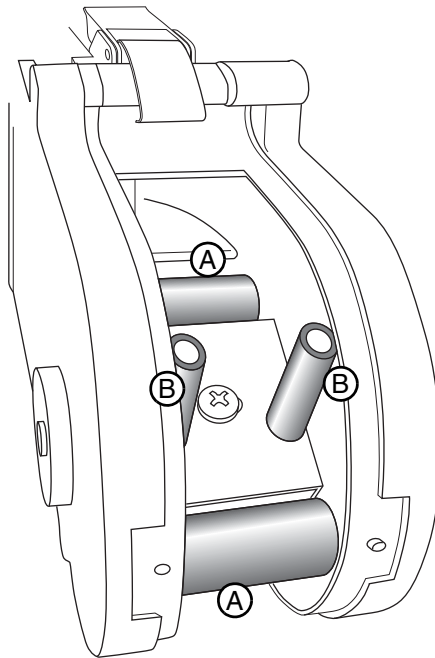

Figure 5-2 Rollers (A) and guides (B) on the pump rotor

- b. **Pump Rotor** – Look for debris build-up on the pump roller or guide surfaces (Figure 5-2). Clean when needed (section 5.1.3).
- c. **Housing** – Look for debris inside the pump housing. Clean as necessary (section 5.1.4). (Debris inside the housing is usually evidence that a pump tube failed.)

5.1.2 Pump Tube Replacement

The correct sampler pump tubing is easily recognized by the blue alignment collars. Table 5-1 lists part numbers for replacement pump tubes. Pump tubing from non-Isco vendors and tubes designed for other types of samplers should not be used. Incorrect pump tubing may result in poor pump performance or even cause parts to fail prematurely. Also note that the discharge tube is not the same as the pump tube.

Refer to Figure 5-1 and the following steps to replace the pump tube.

1. Press the On/Off button to place the sampler in the Standby state. This ensures that the sampler will not attempt to operate the pump.

WARNING

The sampler has a safety interlock that prevents the pump from operating when the pump housing band is open. **DO NOT** tamper with the pump housing and band. The pump is extremely powerful. The pump can injure you severely if the sampler activates the pump while you are working on it. Place the sampler controller in the Standby state before opening the pump housing.

2. Loosen the Liquid Detector Cover (G) by unscrewing the large black knob (I).
3. Unlatch the Pump Housing Band (K).
4. Pull the tube (A) away from the bulkhead fitting (B) and disconnect the tubing coupler and suction line. You may have to cut the tubing to release the coupler.
5. Pull the old pump tube through the pump.
6. Thread the new pump tube through the pump. Note that the short end (inlet) should extend from the top opening.
7. Align the blue collars with the alignment notches.
8. Close the liquid detector cover and secure it tightly with the large knob.
9. Close the pump housing band and secure it with the latch.
10. Reset the pump-tube counter. (See the “Resetting the Pump Tube Alarm” example.)
11. Take a “dry” grab sample (section 4.4) to test the new tube.
12. Reconnect the suction line.

Pump Tube Life – Several factors shorten the pump tube life. Among them are:

- Incorrect installation.
- Abrasive materials suspended in sample liquid.
- Frequent line rinses.
- Long purge cycles, such as those used with long suction lines.

To extend the life of the pump tubes:

- Always use Isco pump tubes.
- Install the tube properly, aligning the blue collars correctly in the notches.
- Follow the natural curve of the tube when wrapping the tube around the pump rollers.
- Minimize the line rinses and sampling retries in the sampling programs.
- Use the shortest possible suction line.

Table 5-1 Replacement Pump Tubes

Part Number	Quantity
60-9004-157	1
68-6700-062	5
68-6700-044	10
68-6700-045	25

Example: Resetting the Pump Tube Alarm

1. From the Main Menu screen select CONFIGURE.

```
PROGRAM  CONFIGURE
VIEW LOG
```

2. Step through the Configure options until you see the TUBING LIFE display. Press Enter

```
SELECT OPTION: (<-->)
TUBING LIFE
```

3. The sampler briefly displays the current pump count information. Line one lists the pump counts since the last reset. Line two lists the current alarm setting. The screen will advance automatically.

```
___ PUMP COUNTS,
WARNING AT ___00000
```

4. To reset the counter to zero, select YES. Always reset the counter after replacing a pump tube. Select NO when merely checking the current count.

```
RESET PUMP COUNTER?
YES NO
```

5. You can modify the pump tube alarm setting to tailor it to your needs. The factory default setting is 1,000,000 pump counts. However you may experience tube wear more or less frequently. Change the pump-count alarm setting by typing the first two digits of the new setting. The sampler accepts entries between 1 and 99. For example, to increase the count to 1,500,000, enter 15.

```
__00000 PUMP COUNTS
TO WARNING
```

A pump tube alarm should be set to notify you when the pump tube should be replaced. A pump tube should be replaced when it begins to show signs of wear, long before the tube wall fails. For more information, refer to section 5.1.1.

5.1.3 Cleaning the Pump Rollers

Debris should be removed from the rollers and guides to keep the pump operating efficiently and to extend tubing life. Remove loose debris from the pump rollers and guides with a stiff nylon-bristle brush. If debris has built up and cannot be removed with the brush, scrape the rollers or guides with a plastic or wooden tool to loosen the debris.

Do not use a metal tool. This might damage the plastic rollers and guides.

5.1.4 Cleaning the Pump Housing

Remove loose debris from the pump housing with a stiff nylon-bristle brush. If needed, flush debris from the housing with water. Do not forcefully spray with water. This might force water through the seals and bushings and damage internal components.

5.1.5 Cleaning or Replacing Wetted Parts

For general cleaning, you can wash the strainer and sample bottles with a brush and soapy water, then rinse with clean water. You can clean the liquid path through the wetted parts (Figure 5-3) by placing the strainer in a cleaning solution and pumping it through the delivery system. Next, place the strainer in clean water and pump it through the delivery system to rinse it. If these items are severely contaminated, replace them.

For application-specific requirements, consult with your laboratory to establish cleaning or replacement protocols.

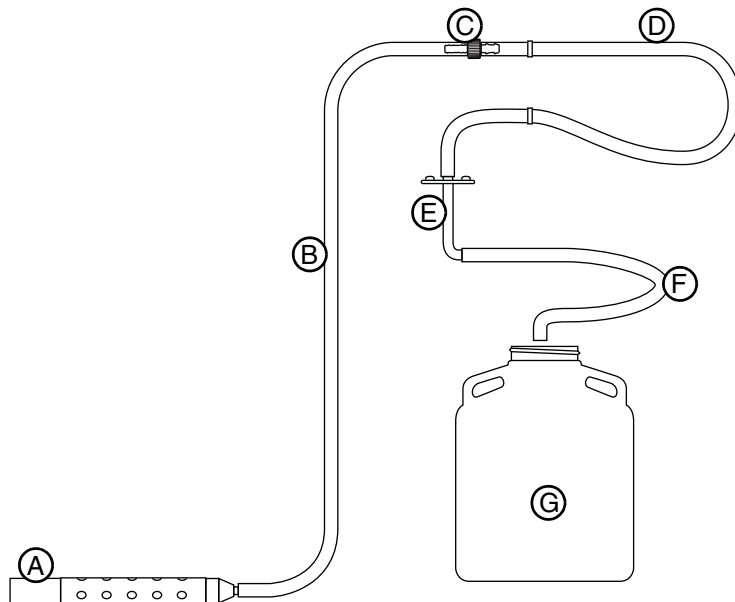

Figure 5-3 Wetted Parts

- | | |
|---|---|
| A. Strainer (316 stainless steel, polypropylene, or CPVC) | E. Bulkhead Fitting (316 stainless steel) |
| B. Suction Line (vinyl) | F. Discharge Tube (silicone) |
| C. Tubing Coupler (316 stainless steel) | G. Bottle (glass, polypropylene, or polyethylene) |
| D. Pump Tube (silicone) | |

5.1.6 Sampler Cleaning Guidelines

Keeping the sampler clean and protected from harsh elements may extend the usable life of the sampler. When necessary, clean the exterior and interior of the sampler with warm soapy water and brush, then rinse with water. Be sure to use a detergent that is compatible with low-density polyethylene and polystyrene. Avoid using strong solvents and acids.

5.2 Sampler Diagnostics

The sampler has built in diagnostics routines that trained service technicians use to confirm that all sampler subsystems are working correctly or to locate faults. Many of the diagnostic routines also can be run in the field.

In many cases the sampler will determine if the test passes or fails.

- If a test passes, the sampler displays a message showing the test passed and emits a short beep.
- If a test fails, the sampler displays a message with some detail about the failure. The unit will emit a wavering tone for five seconds.

In a few cases the service technician must determine if the test passed or failed based on a sampler function that must be observed.

The sampler automatically reverts to the SELECT DIAG menu after displaying the test results or when the test is complete or expired.

To start the diagnostics from the Main Menu screen:

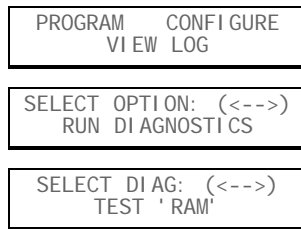

1. Select the CONFIGURE option and press Enter.
2. Press the Previous button until the RUN DIAGNOSTICS option is displayed. Press Enter.
3. The sampler displays a diagnostic option. Press Enter to start the test or press the Next or Previous buttons to scroll through the diagnostic options.

Refer to the sections below for specific information about each test.

5.2.1 Test 'RAM'

The TEST 'RAM' diagnostic tests the sampler's memory that is used dynamically by the sampler's processor and holds program settings and sample event data. This test loads 16-bit words into memory and reads it back to confirm that the memory is working correctly.

To run the test:

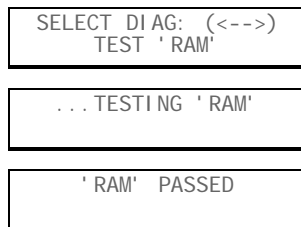

1. Select the TEST 'RAM' option and press Enter.
2. Wait for the sampler to complete the test.
3. When finished, the sampler displays the test results.

If the sampler reports 'RAM' FAILED contact your authorized Isco service facility or the Teledyne Isco factory.

5.2.2 Test 'ROM'

The TEST 'ROM' diagnostic tests the sampler's Read-Only Memory which holds the sampler software. It calculates a checksum total of the data held in this memory and compares it with a known value. If the checksum matches, the ROM test passes.

To run the test:

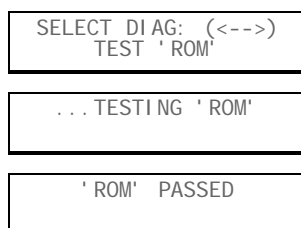

1. Select the TEST 'ROM' option and press Enter.
2. Wait for the sampler to complete the test.
3. When finished, the sampler displays the test results.

If the sampler reports 'ROM' FAILED contact your authorized Isco service facility or the Teledyne Isco factory.

English-language only samplers do not include the known value. For these samplers, the test will report NO CHECKSUM. This result does not indicate a pass or fail state, only that the ROM test is not valid for this particular sampler.

5.2.3 Test Display

The TEST DISPLAY diagnostic tests the sampler's LCD display. It cycles blocks of pixels on and off, then displays characters on the screen. There is no pass or fail message. The technician must watch the display to determine if it is faulty.

To run the test:

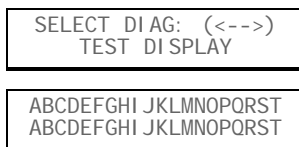

1. Select the TEST DISPLAY option and press Enter.
2. The sampler marches solid boxes across the display, followed by characters. Observe the display. Evidence of a faulty display may include:
 - pixels that never turn on
 - pixels that always stay on
 - garbled text
 - poor contrast.

If any of these or other faulty display conditions exist, contact your authorized Isco service facility or the Teledyne Isco factory.

5.2.4 Test Keypad

The TEST KEYPAD diagnostic tests the sampler's keypad. While the test is active, the display reports the button name of any button you press. There is no pass or fail message. The technician must watch the display to determine if the sampler reports the correct button when it is pressed.

To run the test:

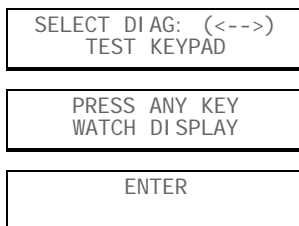

1. Select the TEST KEYPAD option and press Enter.
2. The sampler displays the test instructions.
3. Press any button on the keypad. For example, press the Enter button. The display reports ENTER. The test runs for 20 attempts, then reverts to the SELECT DIAG menu.

If the display does not report the button name when you press it, the keypad could be faulty. Contact your authorized Isco service facility or the Teledyne Isco factory.

5.2.5 Test Pump

The TEST PUMP diagnostic tests the sampler's pump assembly. The sampler operates the pump in each direction and reports an ON/OFF ratio. This ratio is an indication of the pump's mechanical and electronic performance.

To run the test:



1. Select the TEST PUMP option and press Enter. The sampler starts the test and continues without intervention. To cancel the test you can press the Stop button.

PUMPING . . .

PUMPING . . .
ON/OFF RATIO = ____

PURGING . . .

PURGING . . .
ON/OFF RATIO = ____

2. The sampler displays the On/Off ratio. To pass, the number must be between 0.8 and 1.25. The test continues by operating the pump in reverse (purge).

3. The sampler displays the On/Off ratio. To pass, the number must be between 0.8 and 1.25.

If the sampler displays PUMP FAILURE or BAD ON/OFF RATIO, turn off the sampler by pressing the Off button. Then, refer to section 5.1.1 and perform a pump inspection. Clear any obstructions from the pump housing and pump tube, verify that the pump rotor turns, then perform the TEST PUMP diagnostic again. If you don't find obstructions to pump rotor movement, contact your authorized Isco service facility or the Teledyne Isco factory.

5.2.6 Test Distributor

The TEST DISTRIBUTOR diagnostic tests the sampler's distributor assembly. You specify the bottle position to which the sampler should move the arm. You can then verify the correct positioning of the arm.

Note that this test is not applicable for samplers configured for operation with a single bottle.

To run the test:

SELECT DIAG: (<-->)
TEST DISTRIBUTOR

GO TO BOTTLE ____
(1-max)

MOVING TO BOTTLE ____

NOW AT BOTTLE ____

GO TO BOTTLE ____
(1-max)

1. Select the TEST DISTRIBUTOR option and press Enter.
2. Enter the bottle number to which the sampler should move the arm. Press Enter and the distributor will run.
3. The sampler reports the new distributor arm position. Verify that the arm is aligned over the correct bottle. If the arm is not aligned over the bottle, the distributor requires calibration. Contact your authorized Isco service facility or the Teledyne Isco factory.
4. The sampler then asks for the next bottle position. Enter a bottle number and press Enter. Or, press the Stop button to exit the test.

If the sampler displays DISTRIBUTOR JAMMED, DISTRIBUTOR ERROR, SLOT CODE ERROR, DISK ERROR, or BELT TOO LOOSE, verify that the arm movement is not obstructed. Clear any obstructions such as bottles not fully seated in the rack or an incorrectly installed discharge tube, then perform the TEST DISTRIBUTOR diagnostic again from step 1. If you don't find obstructions to the distributor arm movement, contact your authorized Isco service facility or the Teledyne Isco factory.

5.2.7 Test Flow Meter Port

The TEST FLOWMETER PORT diagnostic tests the sampler's ability to send event marks, and receive an enable pin signal and flow pacing pulses.

Note

This diagnostic routine is not for field use. This test requires a test plug which is inserted into the External Device connector.

If you have checked all the connections with the external flow meter and still suspect a fault with the event mark or flow pacing signals, contact your authorized Isco service facility or the Teledyne Isco factory. They will be able to assist you with obtaining a test plug or making the necessary jumper connections to run the test.

To run the test:

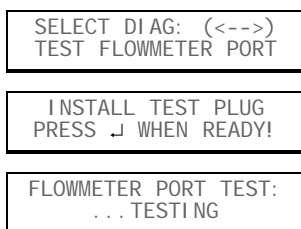

1. Select the TEST FLOWMETER PORT option and press Enter.
2. Insert a Flow Meter Port Test Plug into the Flow Meter connector.
3. The sampler tests the send and receive circuits for the event marks, sampler enable pin (inhibit), and flow pulses.

If the sampler displays FAILED: EM->FP or FAILED: INHIBIT, verify that test plug is correctly inserted. Then, perform the TEST FLOWMETER PORT diagnostic again from step 1. If the test still fails, contact your authorized Isco service facility or the Teledyne Isco factory.

5.2.8 Refrig Temperature

The REFRIG TEMPERATURE diagnostic displays the temperature of the refrigerated compartment. When this test is started, the sampler will display the temperature until you press the Stop or Enter button. There is no pass or fail. This test simply provides continuous temperature monitoring and cooling/heating states.

To display the refrigerator temperature:

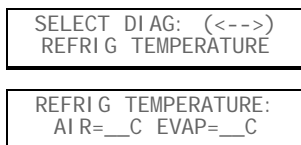

1. Select the REFRIG TEMPERATURE option and press Enter.
2. The display shows the temperature until you press the Stop or Enter button.

5.2.9 PCB Temperature

The TEST PCB TEMPERATURE diagnostic displays the temperature of the Main CPU Printed Circuit Board (PCB). When this test is started, the sampler will briefly display the temperature.

The Main CPU board has a heater which prevents condensation from forming inside the electronics compartment. If the sampler has been connected to AC power for at least 30 minutes, the PCB temperature should be greater than the ambient temperature.

To display the PCB temperature:

SELECT DIAG: (<-->)
PCB TEMPERATURE

PCB TEMPERATURE:
_ . _ C

1. Select the PCB TEMPERATURE option and press Enter.
2. The display briefly shows the temperature.

If you suspect that the internal heater is not working, contact your authorized Isco service facility or the Teledyne Isco factory.

5.2.10 Input Voltage

The INPUT VOLTAGE diagnostic displays the Main CPU board's DC voltage supplied by the power module. When this test is started, the sampler will briefly display the input power voltage.

To display the input voltage:

SELECT DIAG: (<-->)
INPUT VOLTAGE

INPUT VOLTAGE:
_ . _ V

1. Select the INPUT VOLTAGE option and press Enter.
2. The display briefly shows the voltage.

The normal voltage range is between 12.3 and 12.7 VDC. If the voltage is outside of this range, the power supply module is suspect. Contact your authorized Isco service facility or the Teledyne Isco factory for further troubleshooting assistance.

5.2.11 Battery Voltage

The Main CPU board has an internal battery that provides back-up power for the sampler memory while the system is not powered. The battery life is typically longer than five years.

The BATTERY VOLTAGE diagnostic displays no-load DC voltage supplied by the internal battery. When this test is started, the sampler will briefly display the battery voltage.

To display the no-load battery voltage:

SELECT DIAG: (<-->)
BATTERY VOLTAGE

BATTERY VOLTAGE:
_ . _ V

1. Select the BATTERY VOLTAGE option and press Enter.
2. The display briefly shows the voltage.

If the voltage is below 2.2 VDC, the internal battery should be replaced. Contact your authorized Isco service facility or the Teledyne Isco factory for assistance.

Note

Should there be a loss of AC power and the internal battery's no-load voltage is below 2.2 VDC, the sampler might lose data and settings from its memory. It is recommended that you retrieve the data and record the program and configuration settings in case of memory loss.

5.2.12 Loaded Battery Volts

The LOADED BATTERY VOLTS diagnostic displays the loaded DC voltage supplied by the Main CPU board's internal battery. A loaded test provides a better indication of battery performance.

When this test is started, the sampler will display the voltage with a 20K Ω load at one second intervals. The test continues for 15 seconds or until you press the Enter button to abort the test.

Note

Repeated use of the Loaded Battery Volts diagnostic will shorten the battery life.

To display the loaded battery voltage:

SELECT DIAG: (<-->)
LOADED BATTERY VOLTS

LOADED BATTERY VOLTS
__ . __ V

1. Select the LOADED BATTERY VOLTS option and press Enter.
2. The display shows the voltage at 1 second intervals for 15 seconds. You can abort the test by pressing the Enter button.

If the voltage is below 2.2 VDC, the internal battery should be replaced. Contact your authorized Isco service facility or the Teledyne Isco factory for assistance.

Note

Should there be a loss of AC power and the internal battery's loaded voltage is below 2.2 VDC, the sampler might lose data and settings from its memory. It is recommended that you retrieve the data and record the program and configuration settings in case of memory loss.

5.2.13 Analog Input

The ANALOG INPUT diagnostic displays the 4-20 mA current loop input to the sampler. This diagnostic tool is helpful when troubleshooting an analog input from a flow measurement device.

When you start this test, the sampler will display the current reading until you press the Stop or Enter button. There is no pass or fail.

To display the analog input current:

SELECT DIAG: (<-->)
ANALOG INPUT

ANALOG INPUT:
__ . __ mA

1. Select the ANALOG INPUT option and press Enter.
2. The display shows the current reading until you press the Stop or Enter button.

5.3 Temperature Verification

Should there be a need to verify the temperature readings displayed by the control panel, it is important to read the temperature as close as possible to the sensor inside the refrigerator.

To verify the temperature without a 24-bottle rack or locating base, place the refrigerator thermometer in the back-right corner of the refrigerator. The thermometer should sit in front of the return air opening to the refrigeration system, but not obstruct the air flow.

To verify the temperature with the 24-bottle rack, place the refrigerator thermometer on the rack near bottles 20 and 21 (Figure 5-4). For samplers with the bottle locating base, place the refrigerator thermometer between bottles three and four (Figure 5-5).

The refrigerator thermometer can be read after 30 minutes and compared with the displayed refrigerator temperature (section 5.2.8).

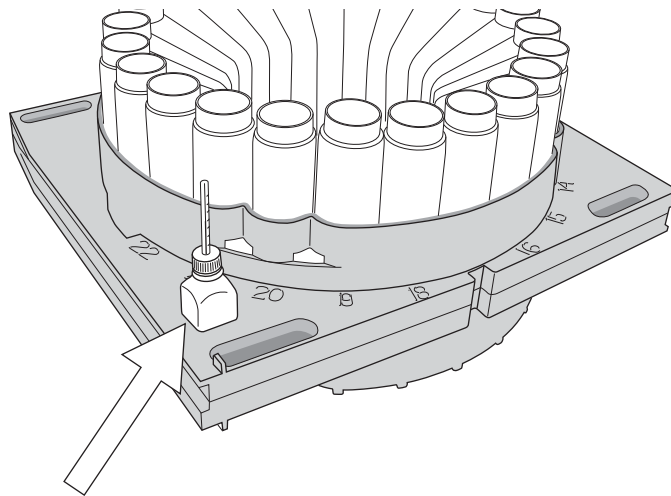

Figure 5-4 Temperature verification with the 24-bottle rack

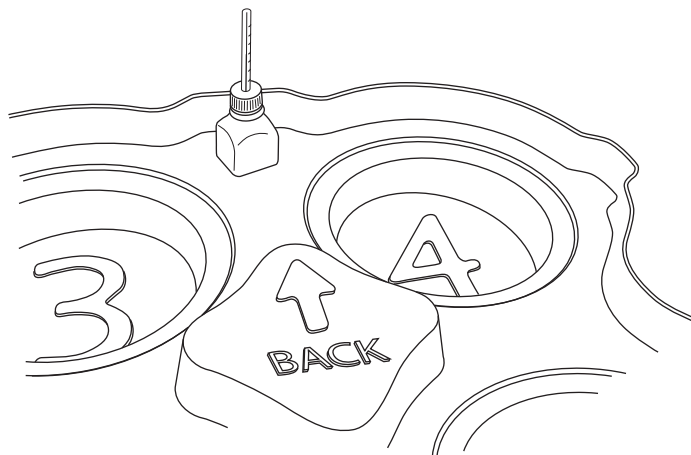

Figure 5-5 Temperature verification with the bottle locating base

4700 Refrigerated Sampler

Appendix A Replacement Parts List

Replacement parts are called out in the following pages. Refer to the call-out in the adjacent table to determine the part number for the item.

Replacement parts can be purchased by contacting Teledyne Isco's Customer Service Department.

Teledyne Isco
Customer Service Department
P.O. Box 82531
Lincoln, NE 68501 USA

Phone: (800) 228-4373
(402) 464-0231
FAX:(402) 465-3022

E-mail: IscoInfo@teledyne.com

A.1 Sampler/Refrigerator Replacement Parts

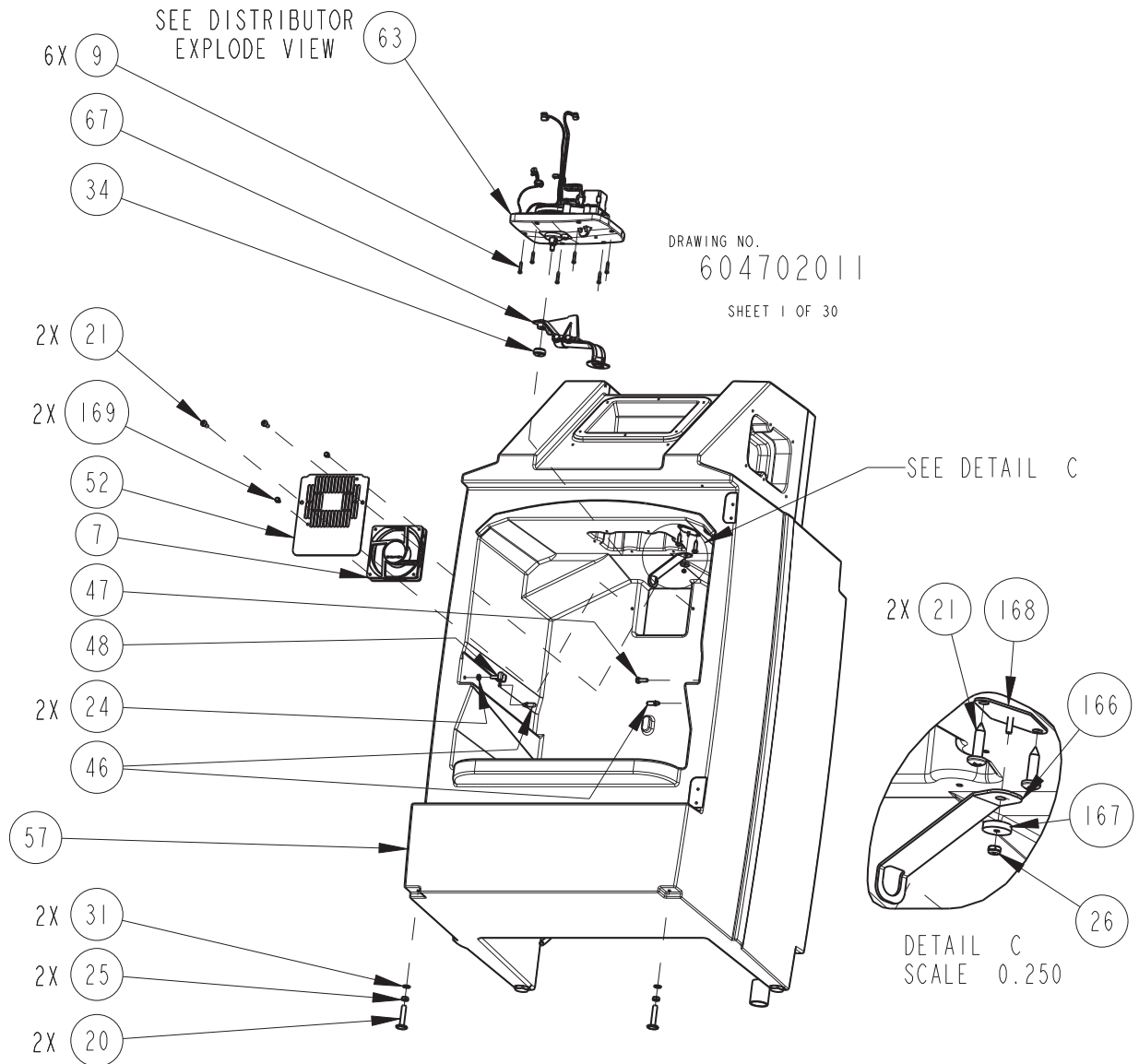

REPLACEMENT PARTS LIST		
TELEDYNE ISCO, INC.		
		604702011
		SHEET: 2 OF 30
		REV: P DATE:
ITEM NO.	PART NUMBER	DESCRIPTION
7	210000410	FAN 12VDC AX FL
9	231014514	SCREW, #8-32 X 7/8 LONG, PANHEAD SST
20	231515964	SCREW, ADJUSTING, 3/8-16 X 2, SST
21	231611620	SCREW, SELF TAP, #14 X 1 LONG, SST
24	232118000	JAM NUT, 1/4-20 X .44 THICK SST
25	232119200	JAM NUT, 3/8-16 X .56 THICK SST
26	232914000	LOCK NUT #6-32, SST W NYLON INSERT
31	233019041	WASHER, FLAT, .390 ID X .63 OD X .063 THK, SST 18-8
46	604703043	TILT STOP
47	604703044	RIGHT STOP
48	604703045	LEFT STOP
52	604703055	FAN MOUNT PLATE
57	604704012	4700 HOUSING WITH FOAM ASSEMBLY (INCLUDES ITEMS 20, 25 & 31)
63	604704029	REPLACEMENT DISTRIBUTOR ASSEMBLY (FOR DETAILS SEE DISTRIBUTOR EXPLODE VIEW)
34	602923007	DISTRIBUTOR ARM NUT
67	604704033	REPLACEMENT DISTRIBUTOR ARM ASSEMBLY
166	604703164	TUBING ARM
167	604703165	TUBING ARM PIVOT
168	604708021	TUBING ARM MOUNT
169	231315908	SCR SLFTPG #10X1/2
NOTE: 1. For current prices and quotations on parts, contact Isco Service Department. 2. This list is subject to change without notice.		

4700 Refrigerated Sampler
Appendix A Replacement Parts List

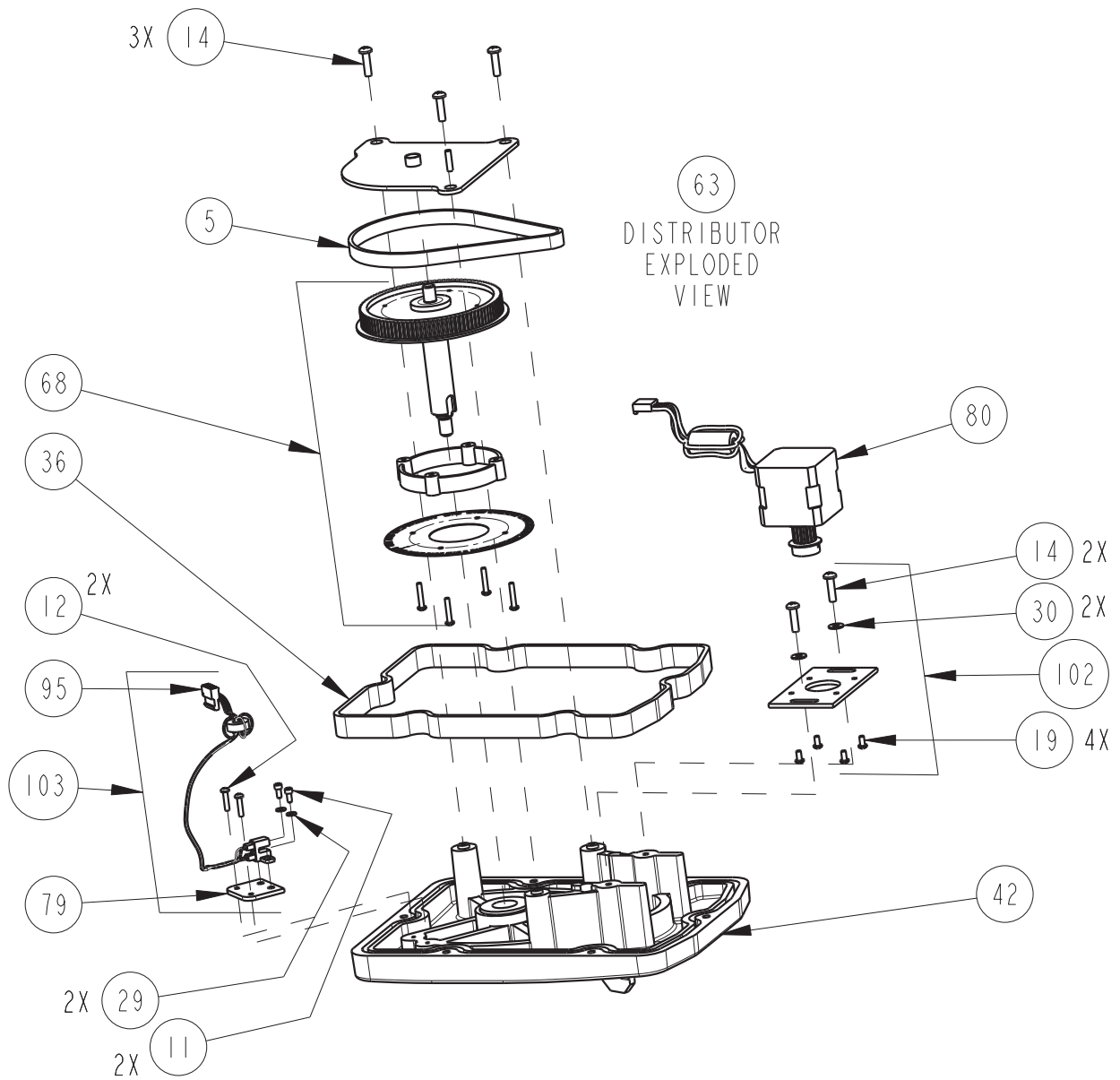

4700 Refrigerated Sampler
Appendix A Replacement Parts List

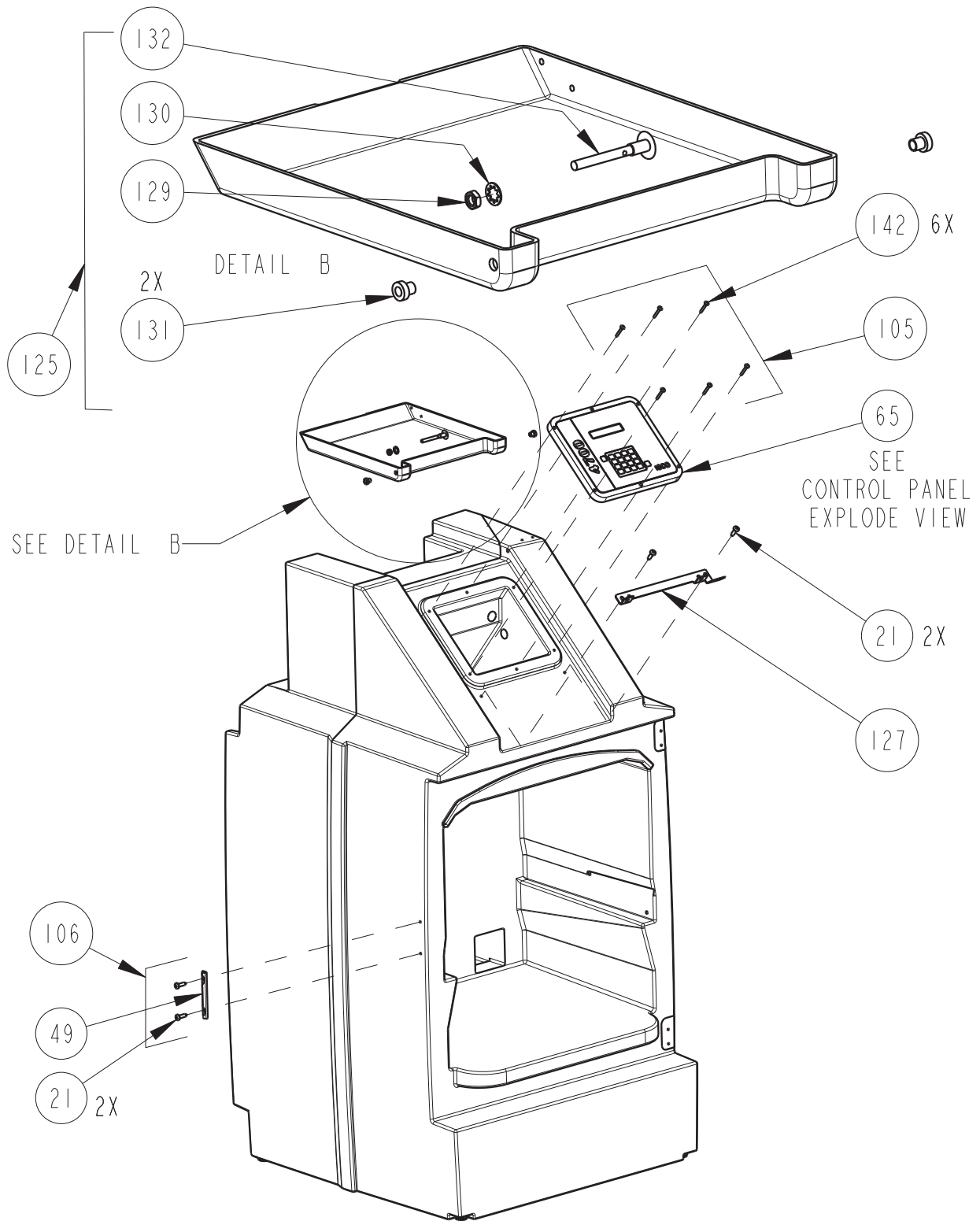

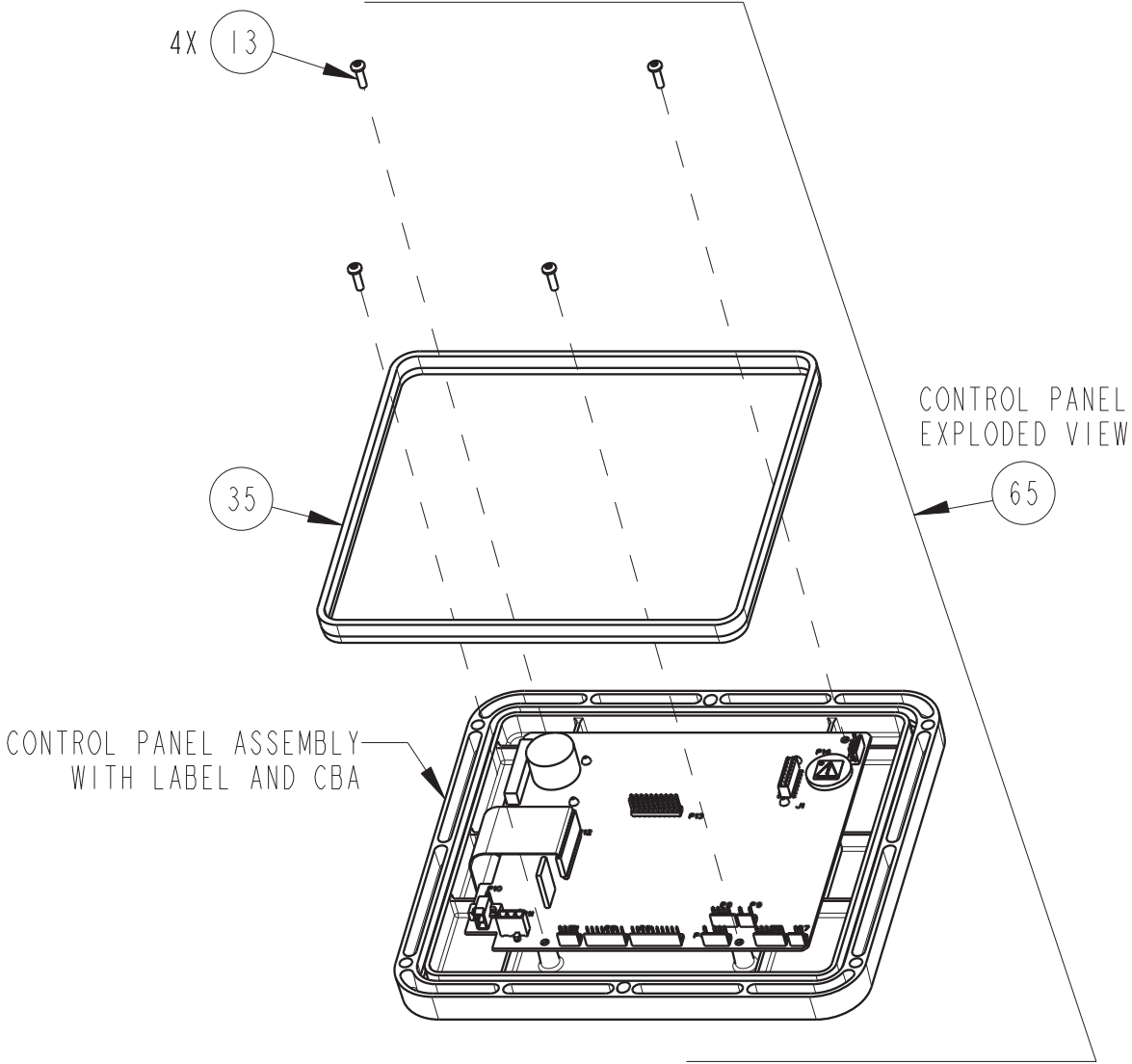



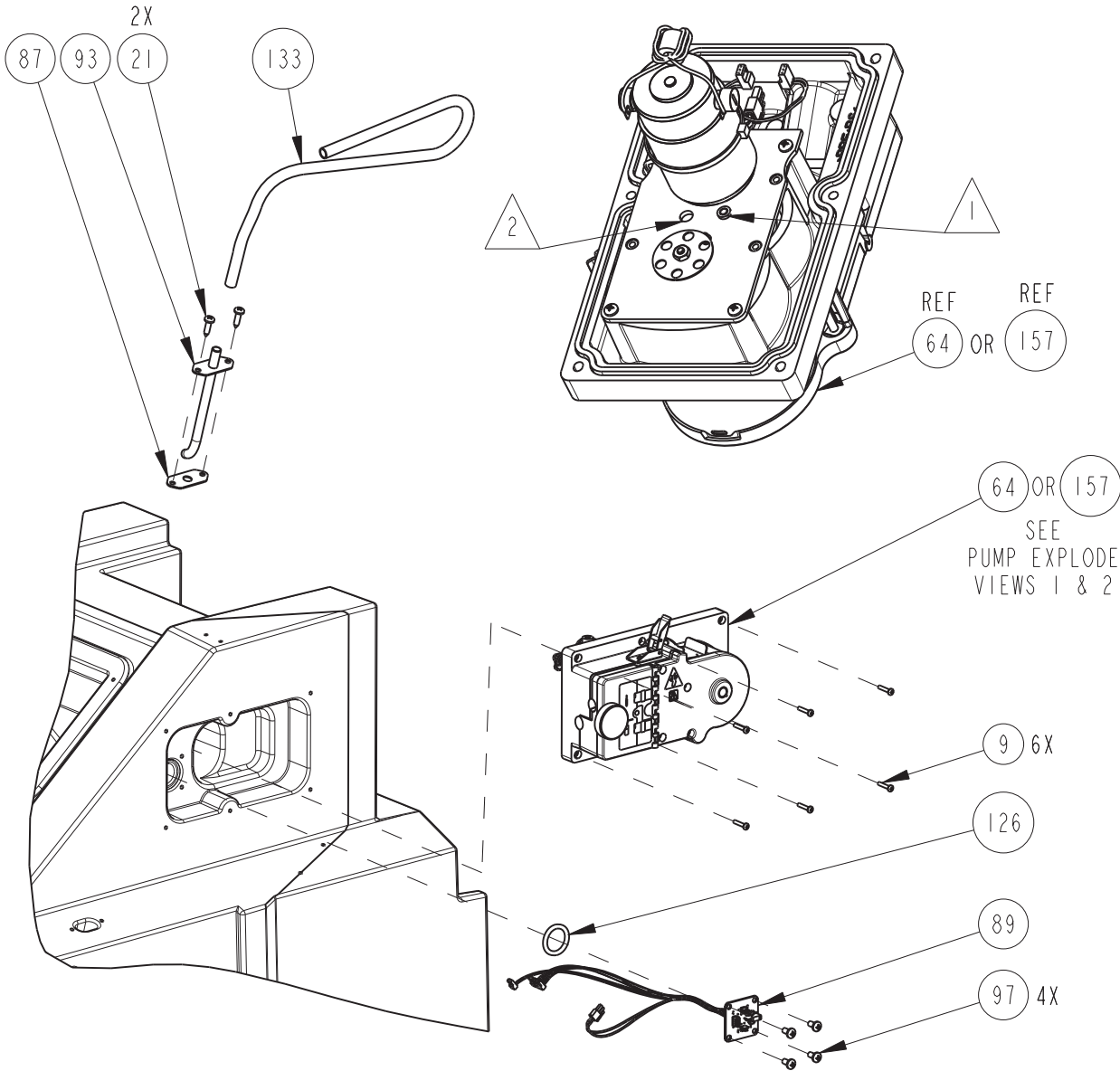

4700 Refrigerated Sampler
 Appendix A Replacement Parts List

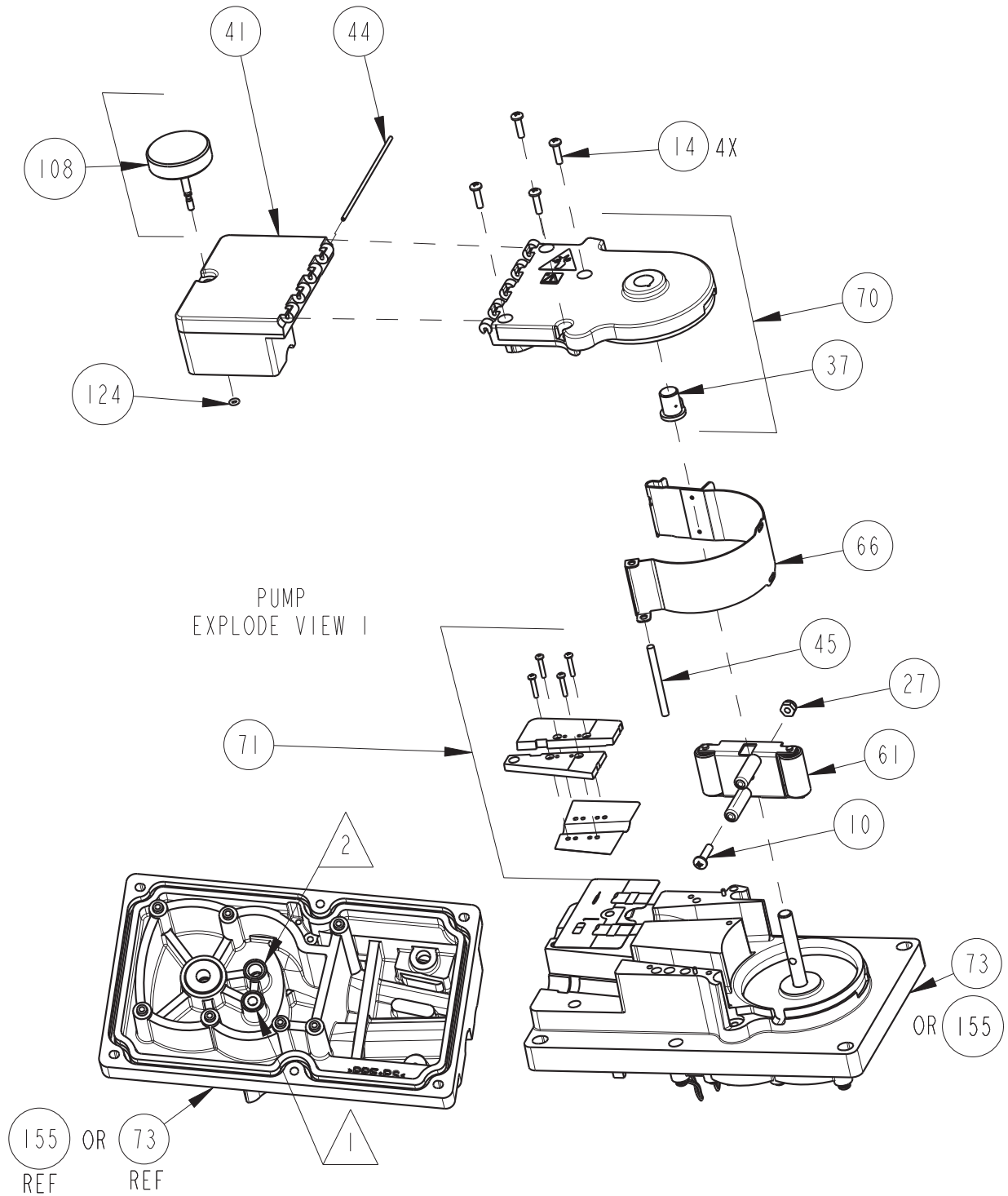







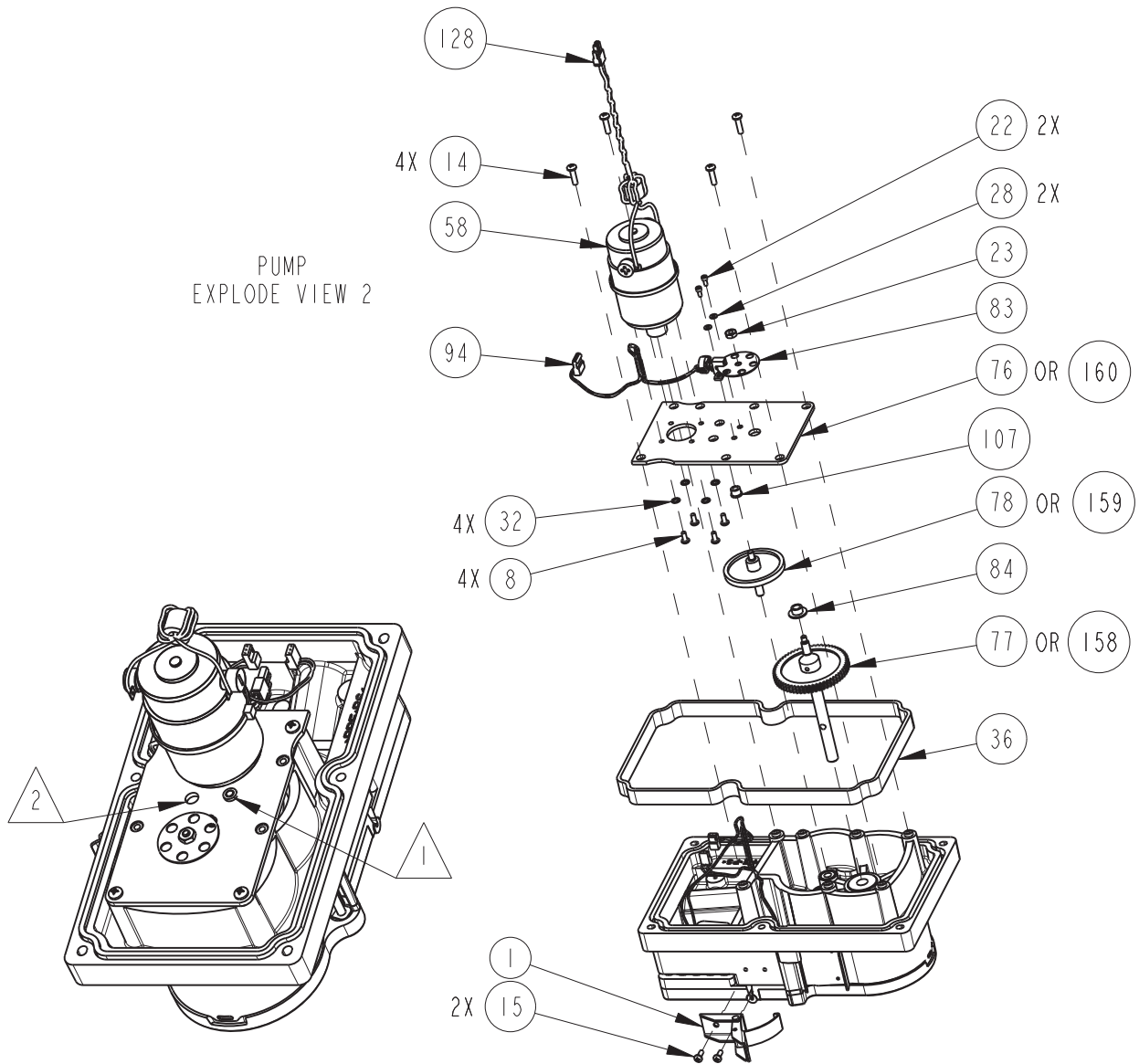

4700 Refrigerated Sampler
 Appendix A Replacement Parts List



REPLACEMENT PARTS LIST			604702011
TELEDYNE ISCO, INC.			SHEET: 12 OF 30
			REV: P DATE:
ITEM NO.	PART NUMBER	DESCRIPTION	
10	231014712	SCREW, MACHINE, #10-30 X 3/4, SST	
14	231310310	SCREW, SELF TAP, #8 X 5/8 LONG, SST	
27	232916101	NUT, LOCK 10-32, NYLON INSERT, SST	
37	603703278	PUMP HOUSING BEARING	
41	604703011	DETECTOR TOP	
44	604703026	HINGE PIN FOR DETECTOR COVER	
45	604703027	HINGE PIN FOR PUMP BAND	
61	604704024	PUMP PADDLE ASSEMBLY	
66	604704032	REPLACEMENT PUMP BAND ASSEMBLY	
70	604704036	REPLACEMENT PUMP COVER WITH CAUTION LABEL (INCLUDES ITEMS 37)	
71	604704037	REPLACEMENT FLUOROGLASS HOLD DOWN KIT	
155	604704141	REPLACEMENT PUMP BASE WITH PIEZO 	
73	604704039	REPLACEMENT PUMP BASE WITH PIEZO 	
108	604704055	REPLACEMENT THUMB SCREW (INCLUDES ITEM 124)	
124	202500007	O RING .1451D X .070 CROSS SECTION	
<p>NOTES:</p> <p> IF BEARING IS IN THIS HOLE, ORDER THIS ONE.</p> <p> IF BEARING IS IN THIS HOLE, ORDER THIS ONE.</p>			
<p>NOTE: 1. For current prices and quotations on parts, contact Isco Service Department. 2. This list is subject to change without notice.</p>			

4700 Refrigerated Sampler
 Appendix A Replacement Parts List



REPLACEMENT PARTS LIST			604702011
TELEDYNE ISCO, INC.			SHEET: 14 OF 30
		REV: P	DATE:
ITEM NO.	PART NUMBER	DESCRIPTION	
1	109080300	DRAW LATCH, LIGHT DUTY, SST	
8	231014405	SCREW, #6-32 X 5/16 LONG, PAN, SST	
14	231310310	SCREW, SELF TAP, #8 X 5/8 LONG, PAN, SST	
15	231311206	SCREW, SELF TAP, #6-18 X 3/8 LONG, SST	
11	231116304	SCREW, CAP, #4-40 X 1/4 LONG, SST	
23	232115000	HEX NUT, #8-32 X 11/32 X 1/8 THICK, SST	
28	233010403	WASHER, FLAT, #4, .13 ID X .25 OD X .02 THICK, SST	
32	233210800	WASHER, LOCK, #6 INTERNAL TOOTH, SST	
36	603113029	CASE TOP BAND GASKET	
58	604704014	MOTOR AND GEAR ASSEMBLY	
160	604708018	MOTOR MOUNT PLATE (INCLUDES ITEM 107) 	
76	604708001	MOTOR MOUNT PLATE (INCLUDES ITEM 107) 	
158	604708016	PUMP SHAFT ASSEMBLY, 60T GEAR 	
77	604708002	PUMP SHAFT ASSEMBLY, 56T GEAR 	
159	604708017	IDLER GEAR ASSEMBLY 	
78	604708003	IDLER GEAR ASSEMBLY 	
83	609003112	PUMP SHAFT OPTICAL DISK	
84	609003556	THRUST SPACER BUSHING	
94	694704025	PUMP SENSOR WIRING ASSEMBLY, CE	
107	201311500	BEARING, CYL, .188 ID X .310 OD X 1/4 LONG	
128	694704027	PUMP MOTOR WIRING ASSEMBLY	
<p>NOTES:</p> <p> IF BEARING IS IN THIS HOLE ORDER THIS ONE.</p> <p> IF BEARING IS IN THIS HOLE ORDER THIS ONE.</p>			
<p>NOTE: 1. For current prices and quotations on parts, contact Isco Service Department. 2. This list is subject to change without notice.</p>			

4700 Refrigerated Sampler
Appendix A Replacement Parts List

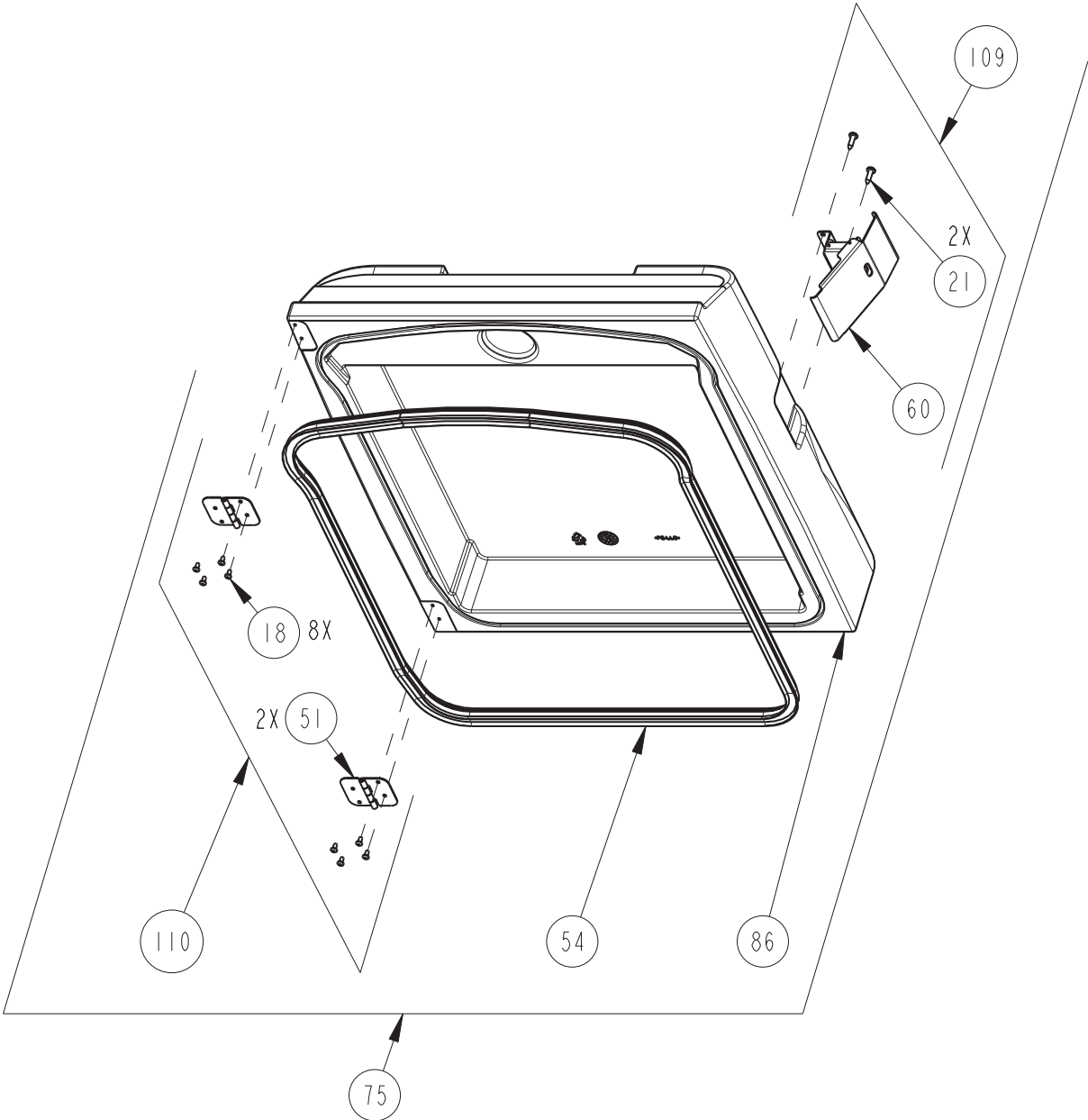

4700 Refrigerated Sampler
 Appendix A Replacement Parts List

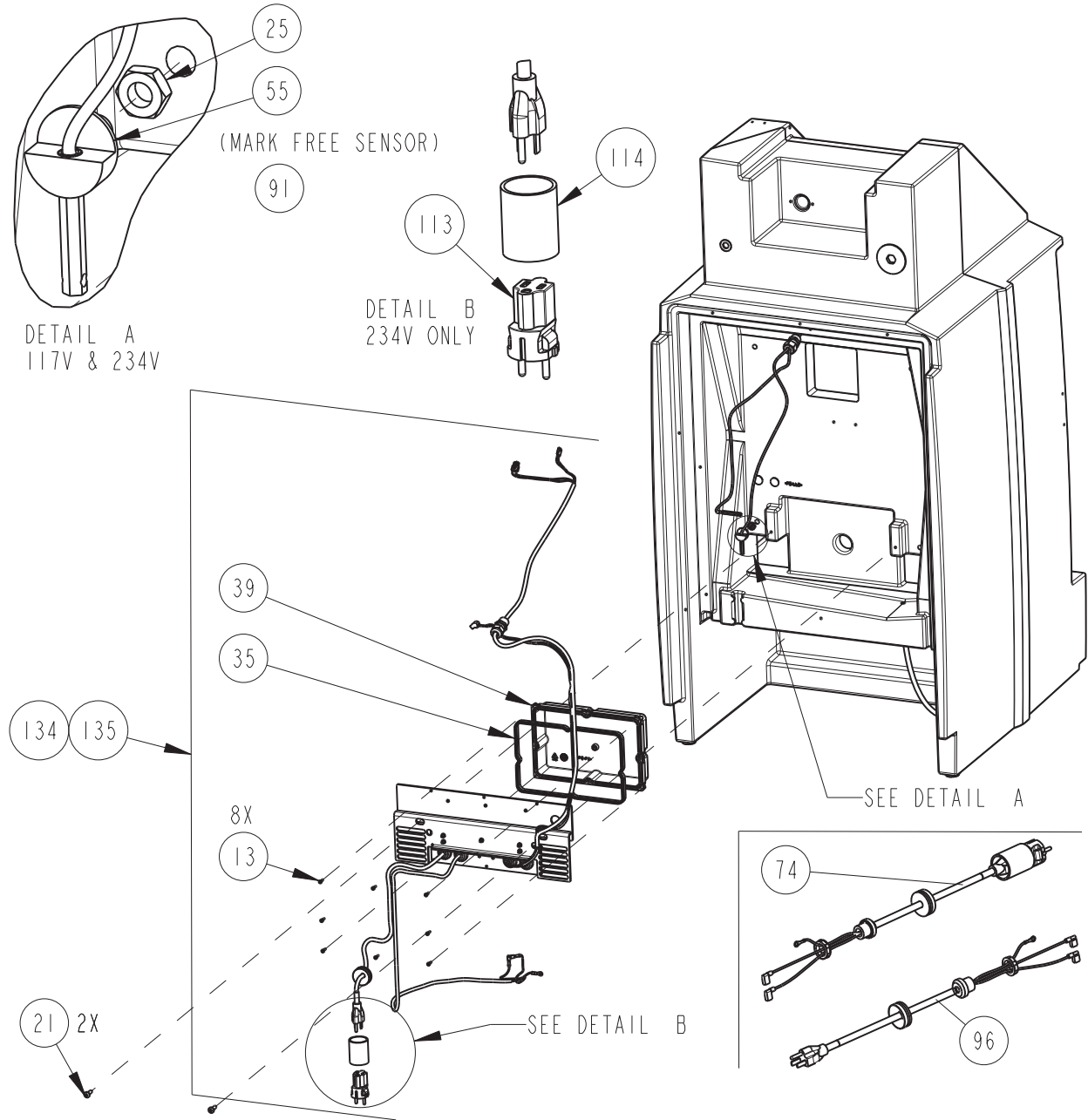

4700 Refrigerated Sampler
Appendix A Replacement Parts List

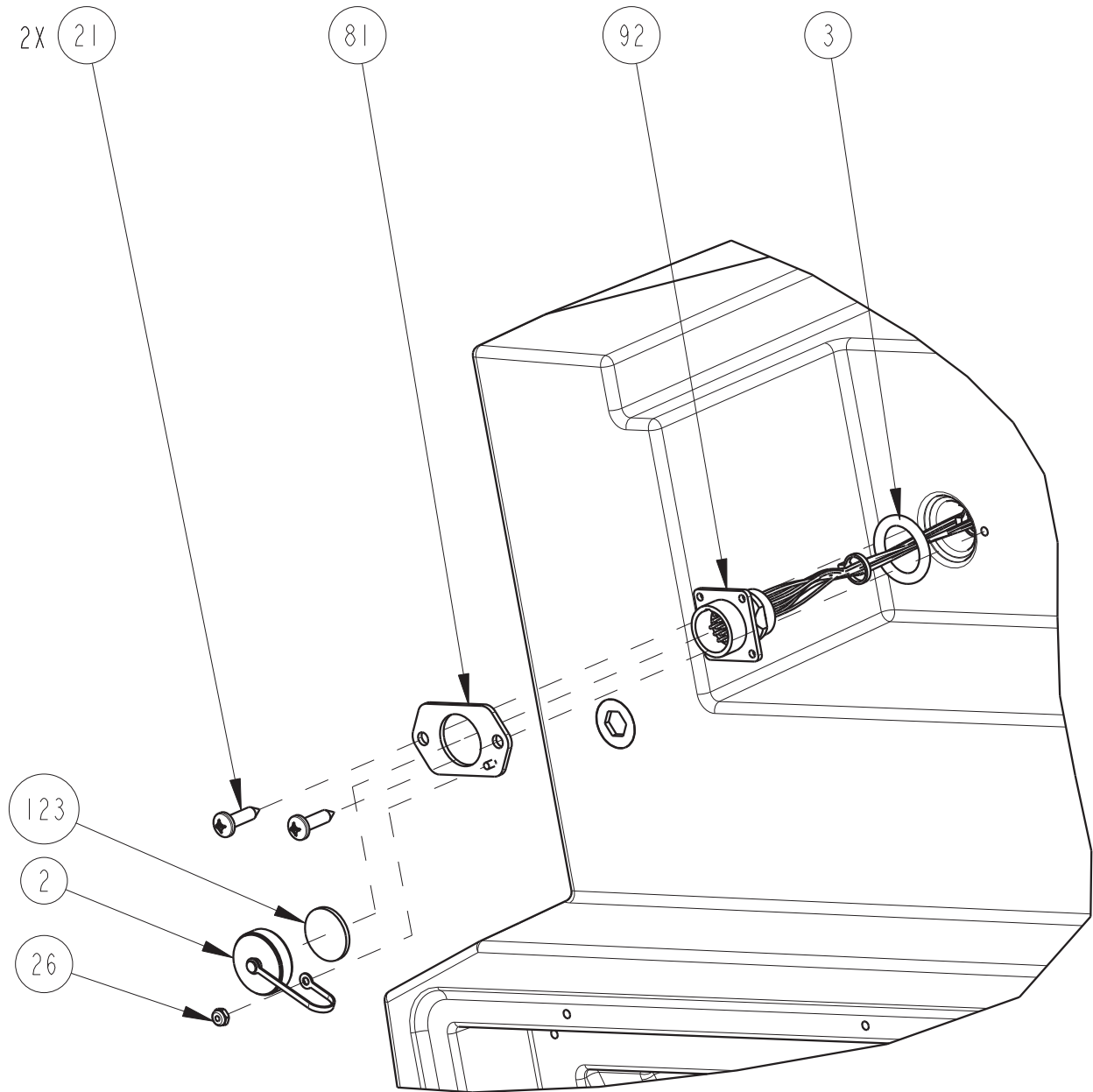

4700 Refrigerated Sampler
Appendix A Replacement Parts List

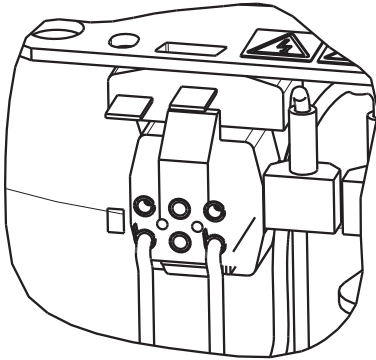

117V VIEW

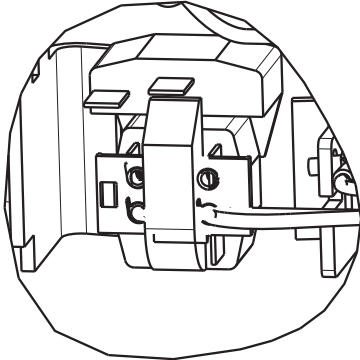

234V VIEW

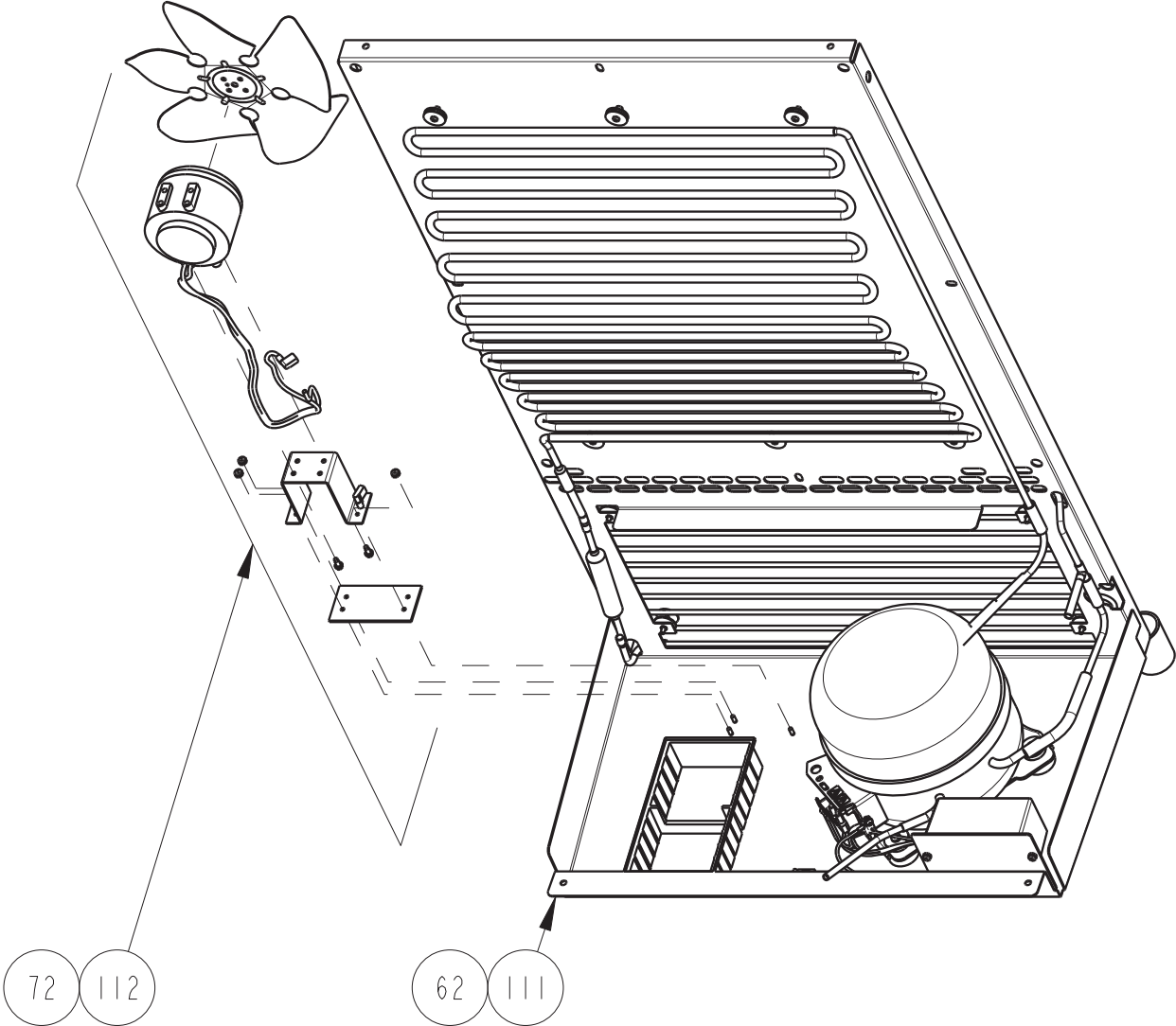

4700 Refrigerated Sampler
 Appendix A Replacement Parts List

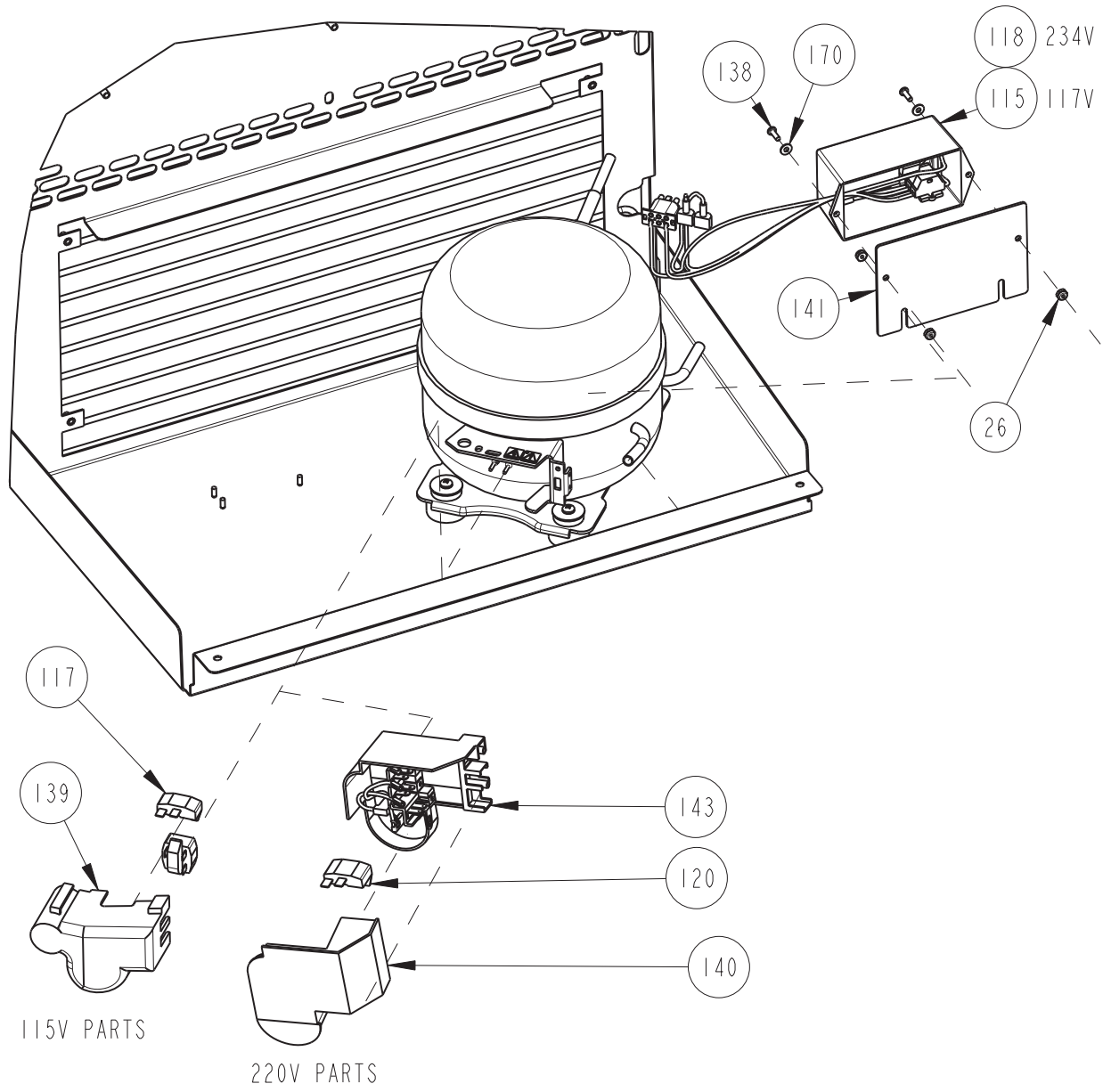

4700 Refrigerated Sampler
Appendix A Replacement Parts List

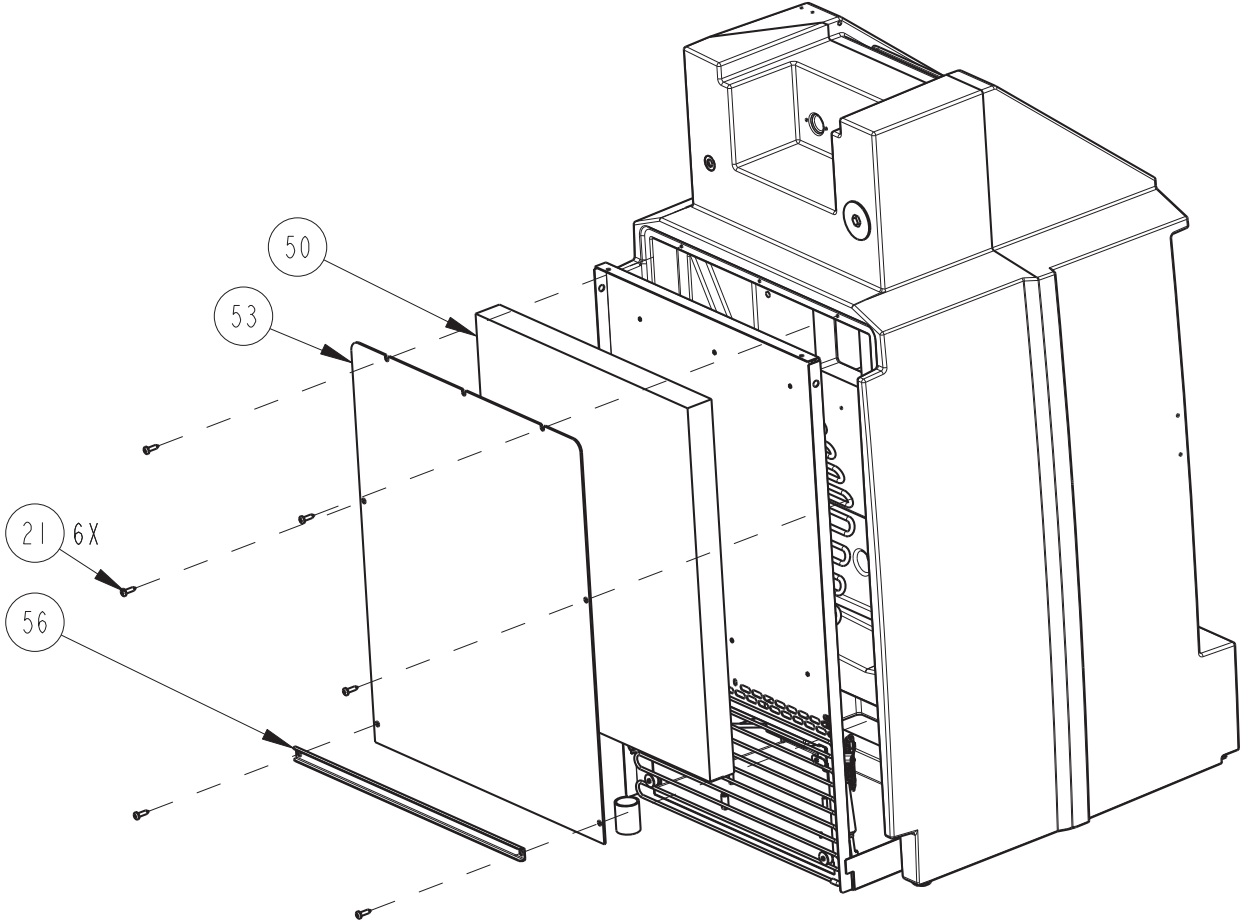

4700 Refrigerated Sampler
Appendix A Replacement Parts List

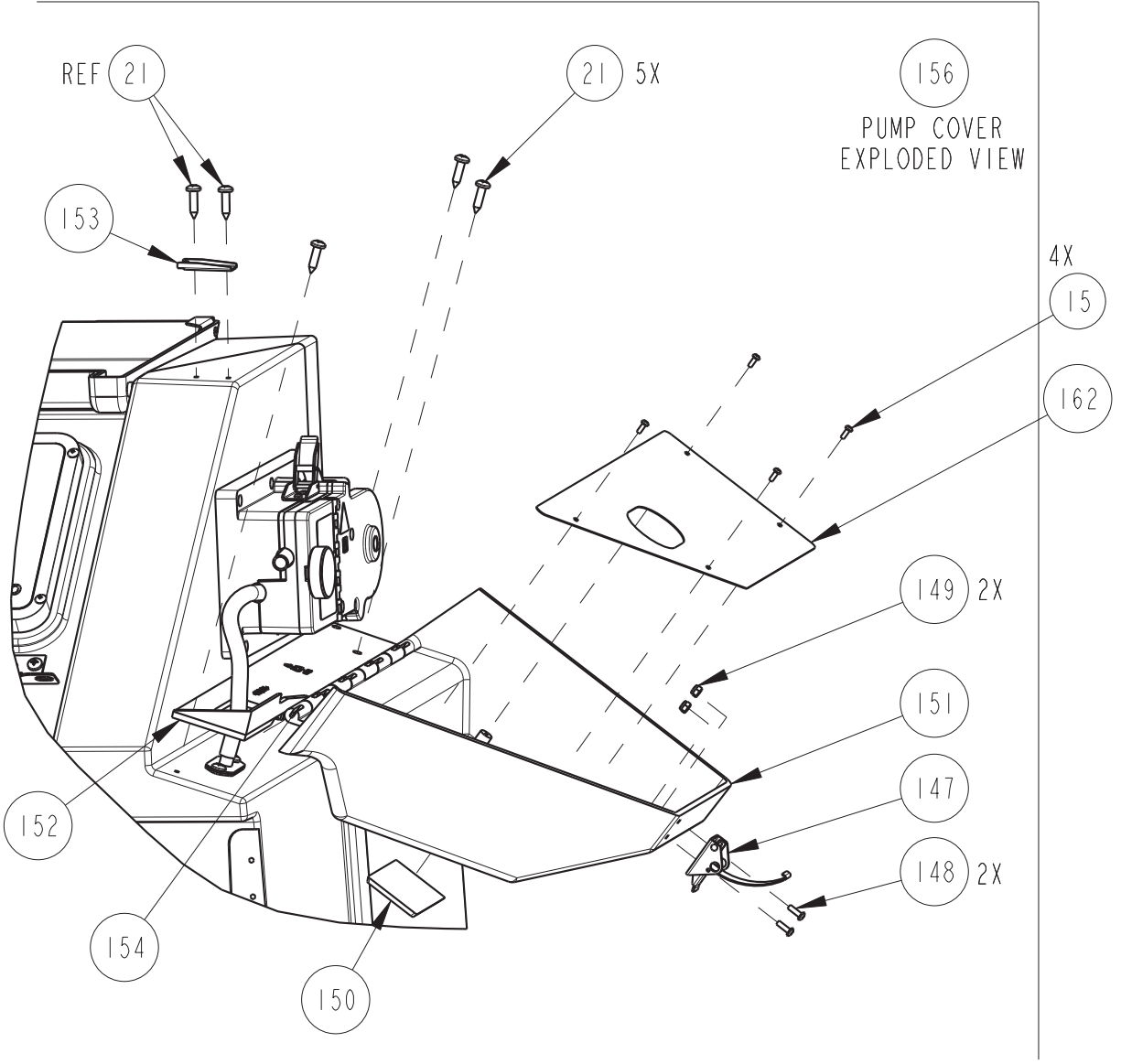

4700 Refrigerated Sampler
Appendix A Replacement Parts List

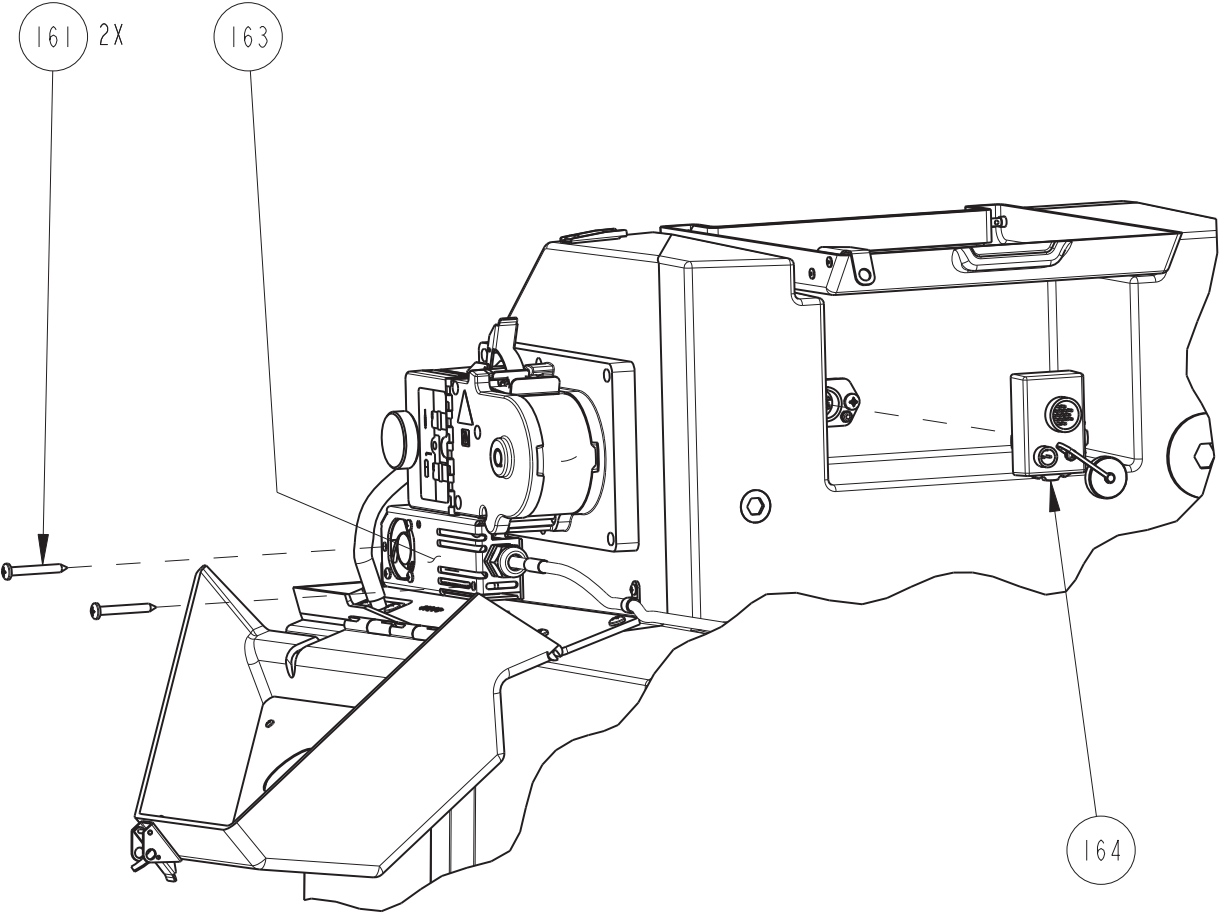

**A.2 Bottle Configuration
Replacement Parts**

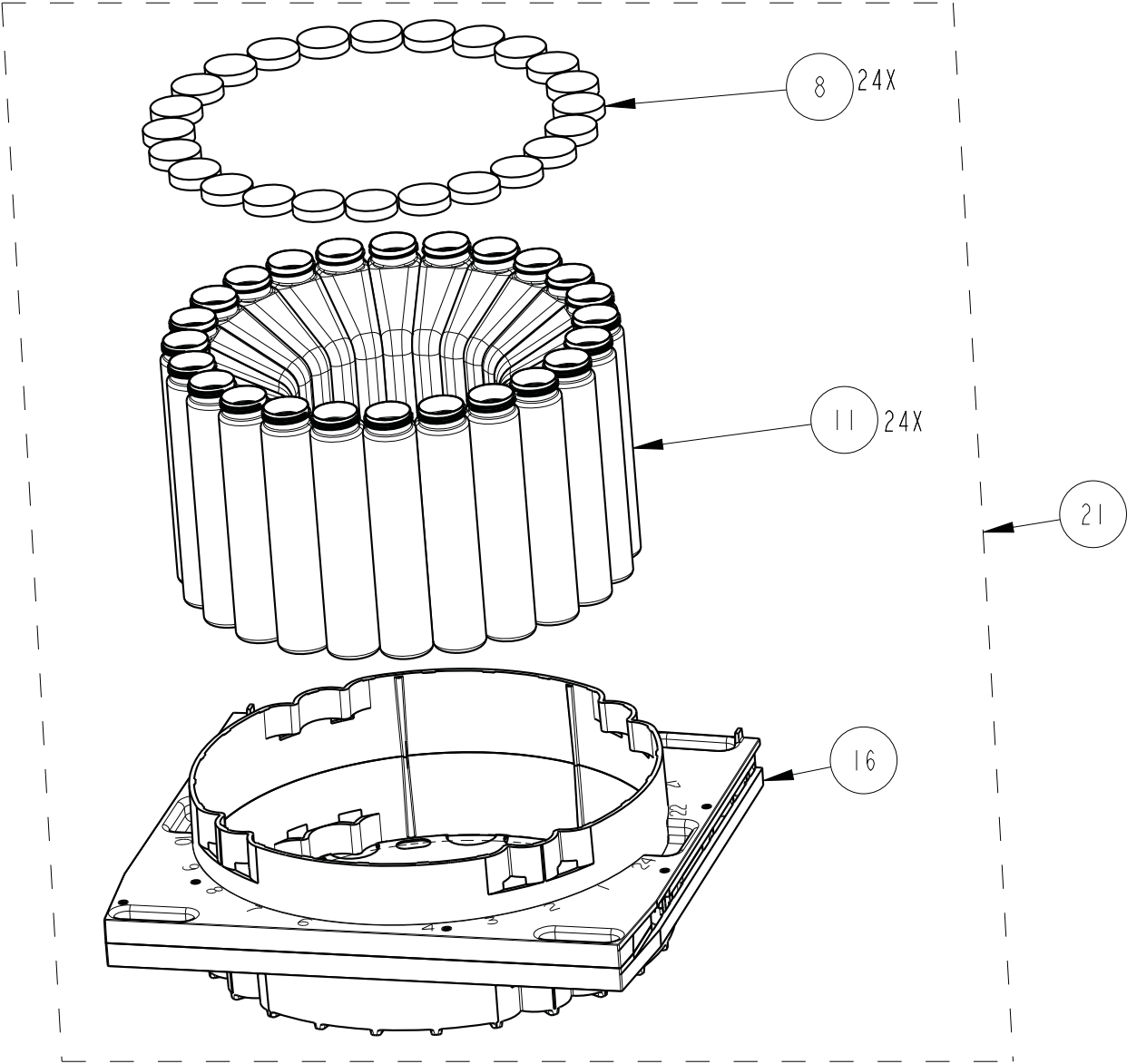

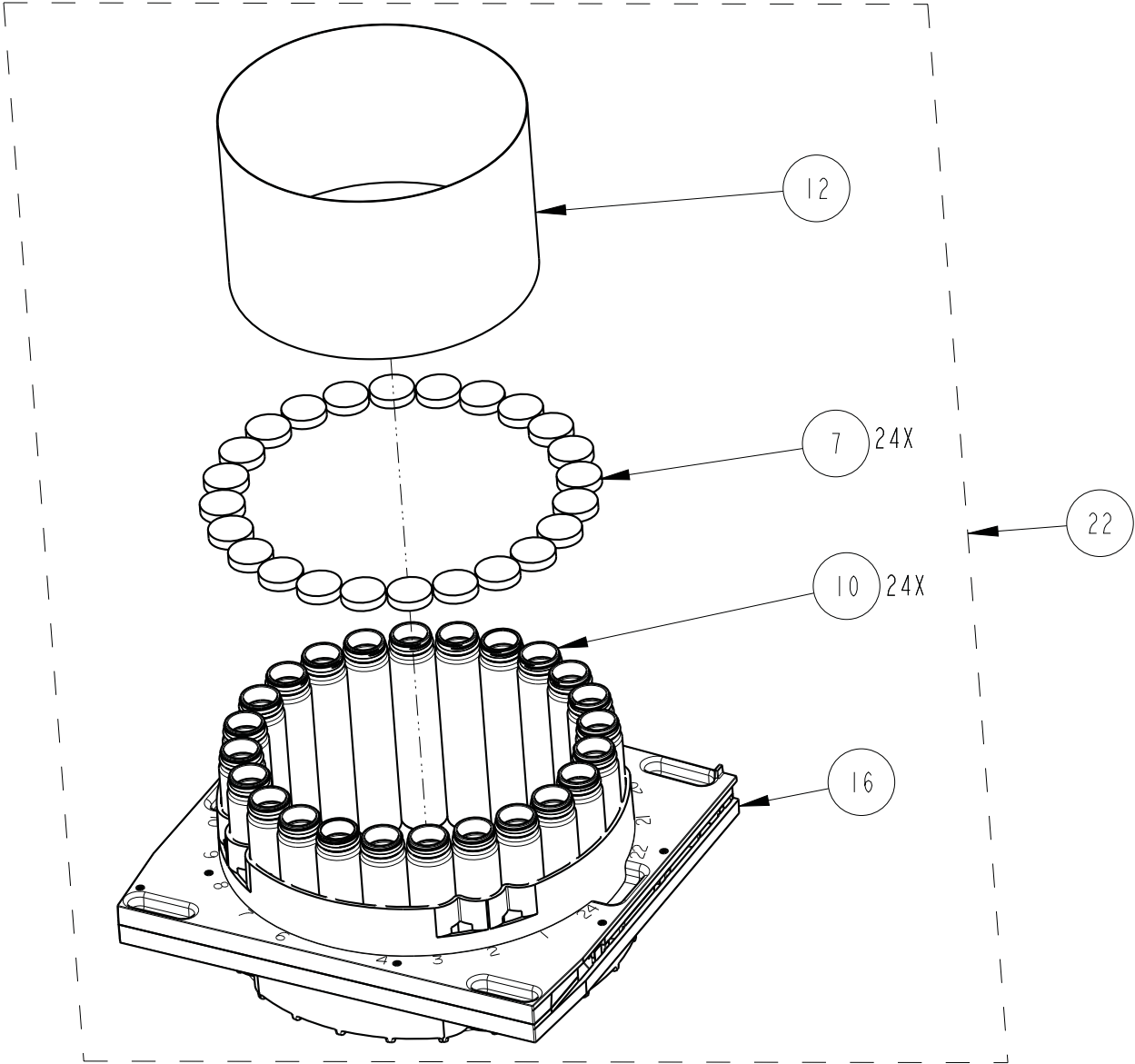

4700 Refrigerated Sampler
Appendix A Replacement Parts List

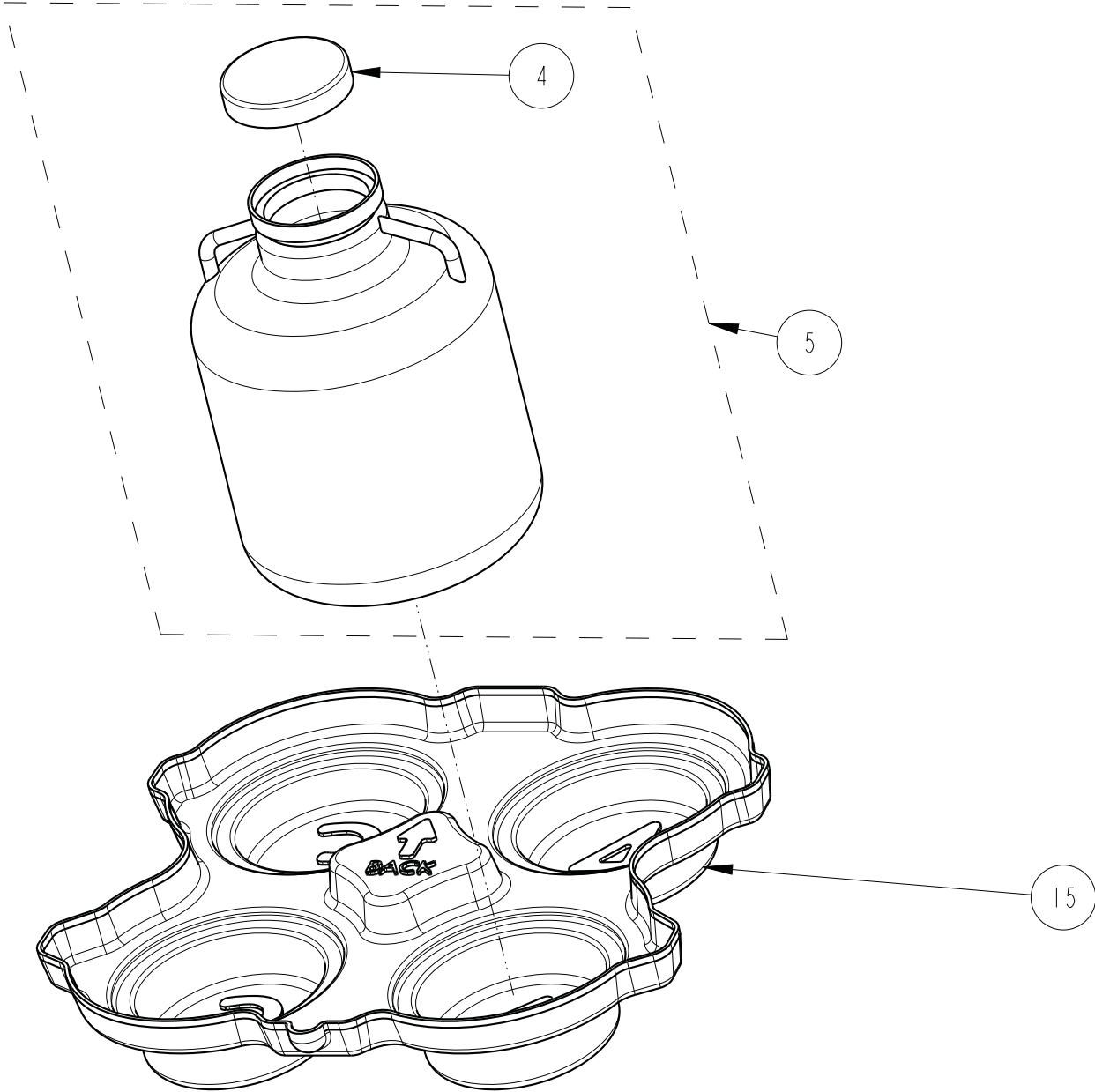

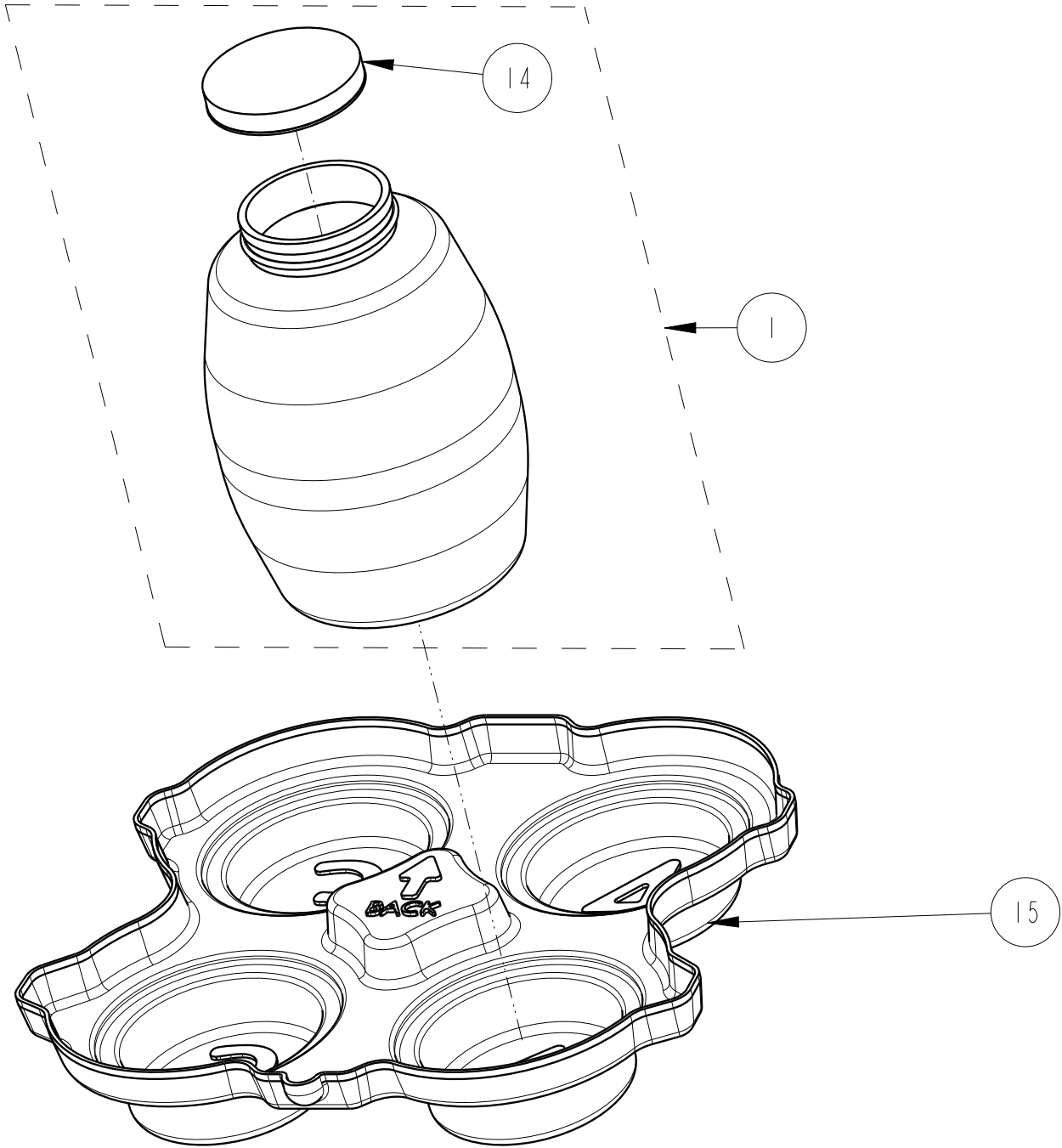

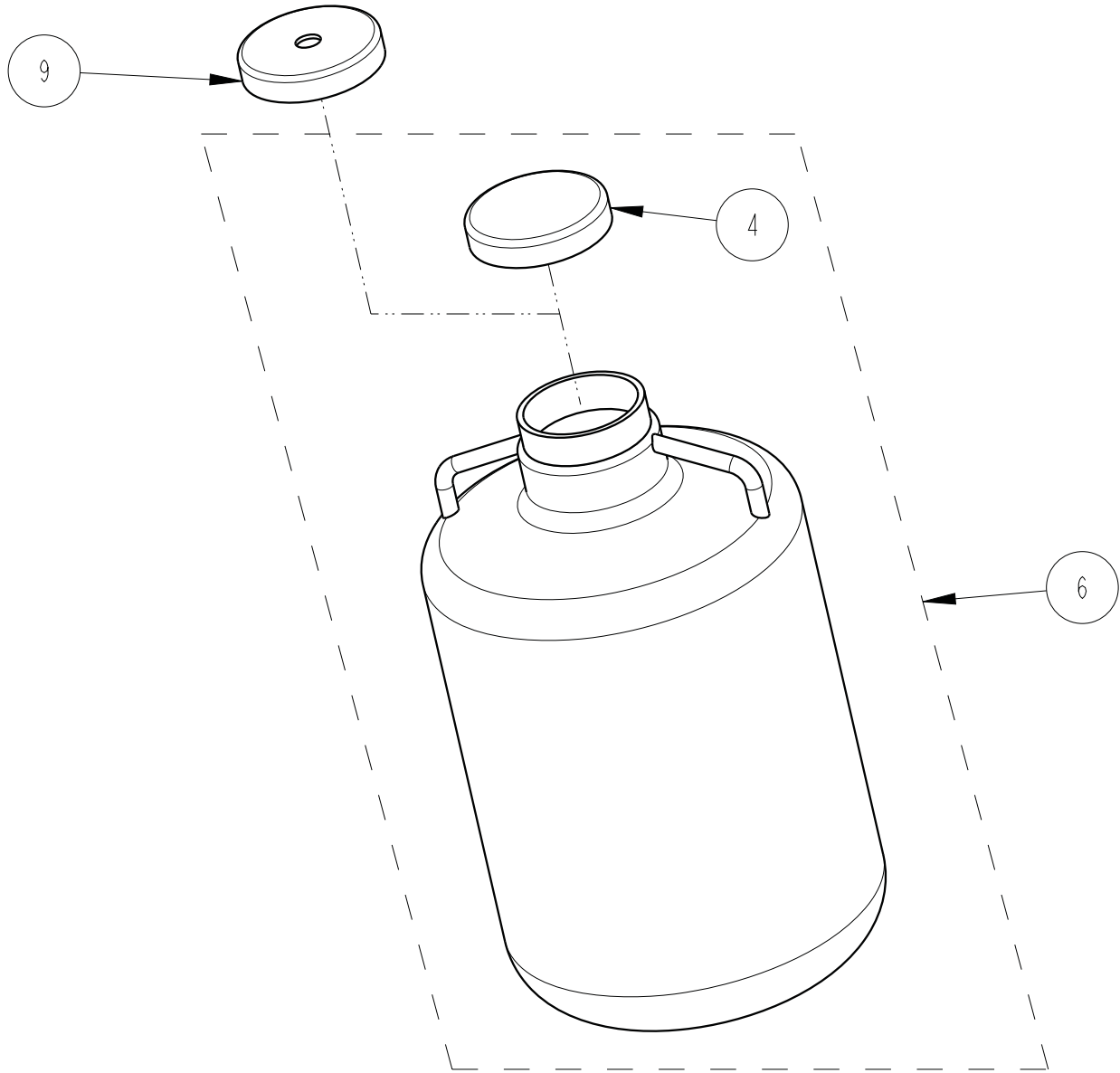

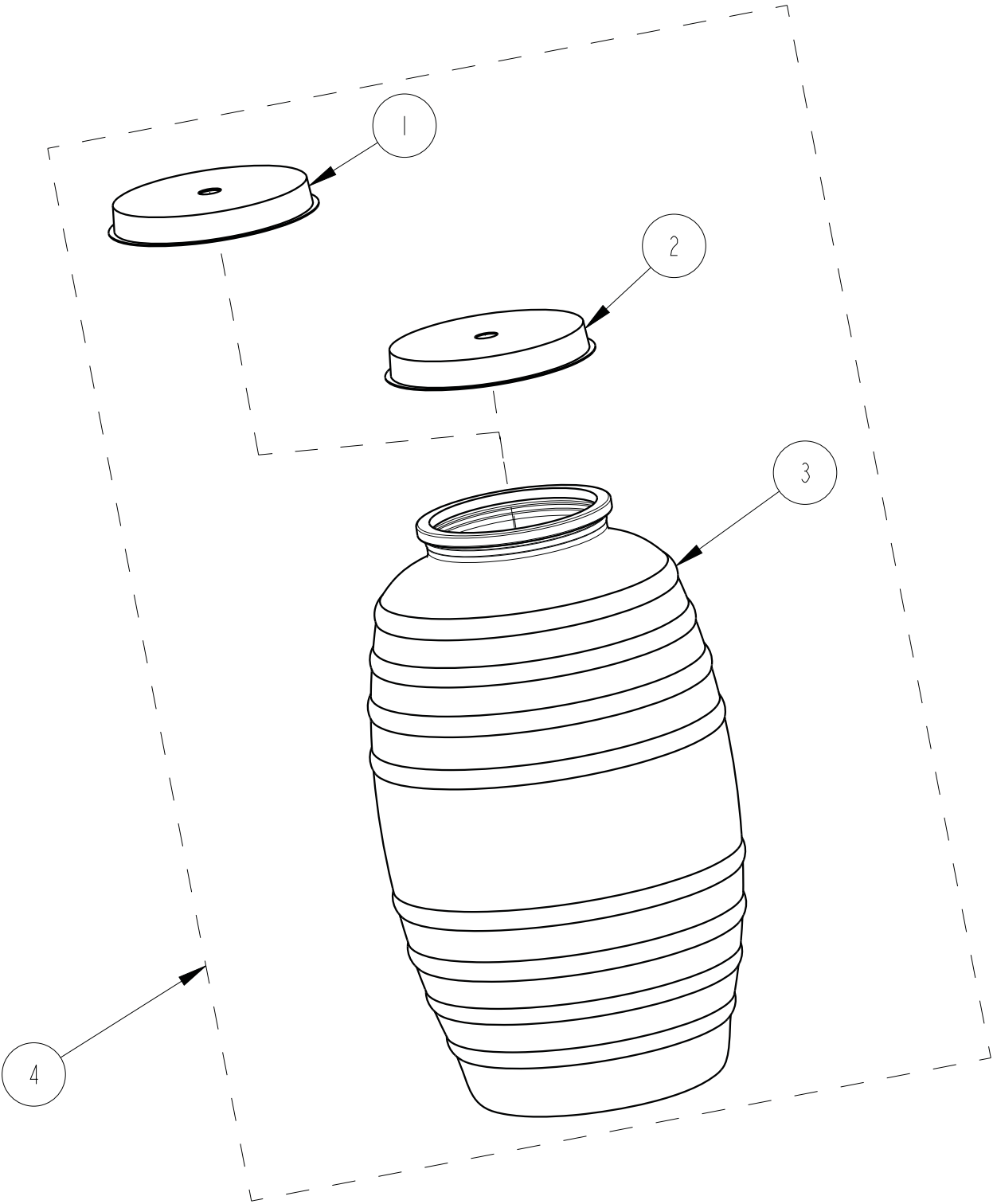

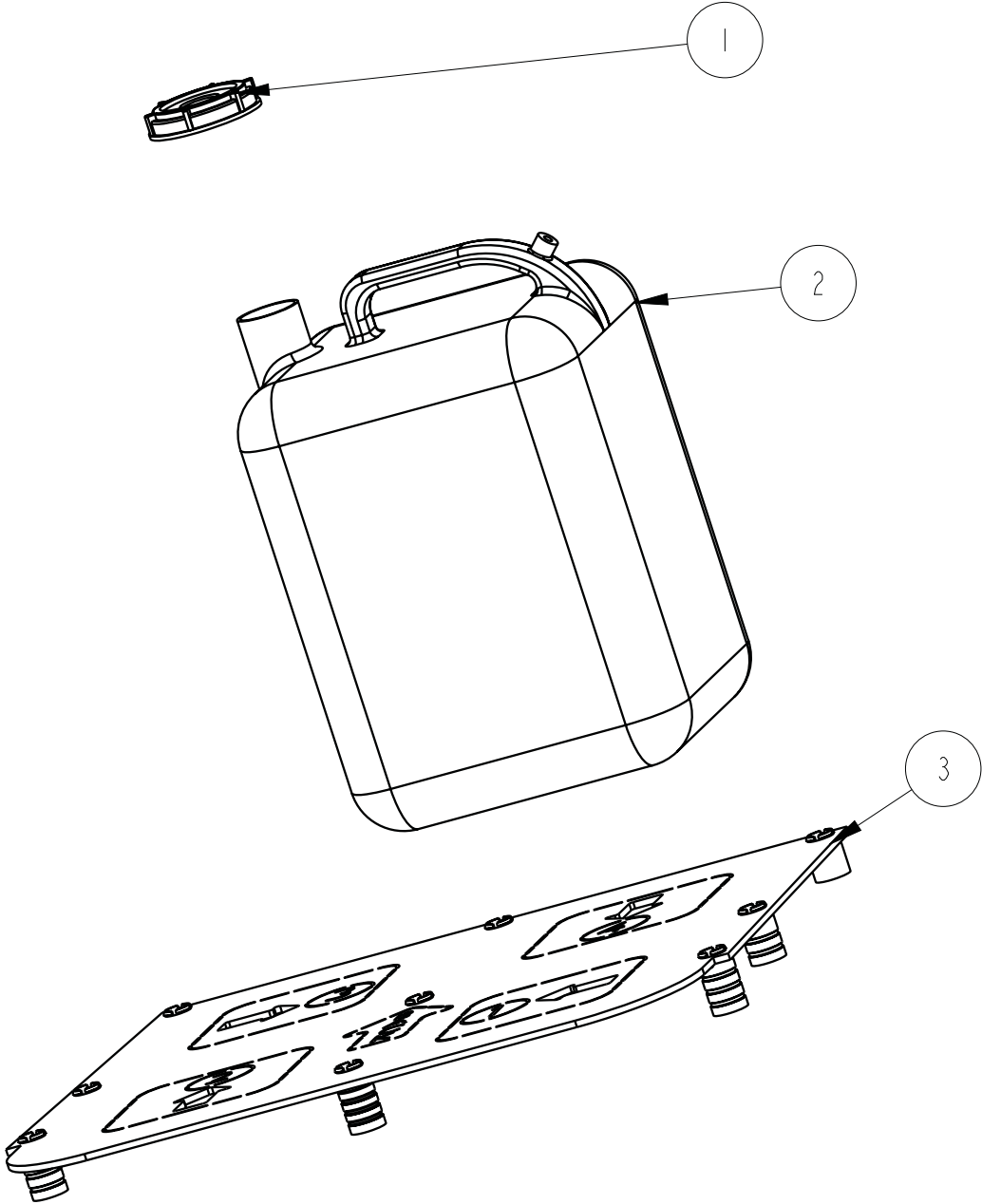

Isco 4700 Refrigerated Sampler

Appendix B General Safety Procedures

The safety of the personnel who use the sampler is a critical consideration. The following procedures, applicable to working in and around manholes and sewers, are those used by Black & Veatch, a respected consulting firm, and are published here by their permission.

Field personnel must keep safety uppermost in their minds at all times. When working above ground, rules of common sense and safety prevail. However, when entering manholes, strict safety procedures must be observed. Failure to do so could jeopardize not only your own life, but also the lives of other crew members.

 **WARNING**

The sampler has not been approved for use in hazardous locations as defined by the National Electrical Code.

 **CAUTION**

Before you install any sampler, you must take the proper safety precautions. The following discussion of safety procedures offers only general guidelines. Each situation in which you install a sampler varies. You must take into account the individual circumstances of each installation.

Additional safety considerations, other than those discussed here, may be required. Check applicable guidelines, codes, and regulations of federal, state, city, and county agencies.

B.1 Hazards

There are many hazards connected with entering manholes. Some of the most common hazards are:

- *Adverse Atmosphere*—The manhole may contain flammable or poisonous gases or the atmosphere may be deficient in oxygen. Forced ventilation may be necessary.
- *Deteriorated Rungs*—Manhole steps may be corroded and not strong enough to support a man. It may be difficult to inspect the rungs because of poor lighting.
- *Traffic*—Whenever manholes are located in the traveled way, barricades and warning devices are essential to direct traffic away from an open manhole.
- *Falling Objects*—Items placed near the manhole opening may fall and injure a worker in the manhole. All loose items should be kept away from the manhole opening.

This applies to hand tools as well as stones, gravel and other objects.

- *Sharp Edges*—Sharp edges of items in or near a manhole may cause cuts or bruises.
- *Lifting Injuries*—Unless proper tools are used to remove manhole covers, back injuries or injuries to hands or feet may result.

B.2 Planning

Advance planning should include arrangements for test equipment, tools, ventilating equipment, protective clothing, traffic warning devices, ladders, safety harness, and adequate number of personnel. Hasty actions may result in serious injuries. Time spent in the manhole should be kept to a minimum.

B.3 Adverse Atmospheres

[Refer to the table of Hazardous Gases at the end of this appendix.] Before workers enter a manhole, tests should be made for explosive atmosphere, presence of hydrogen sulfide, and oxygen deficiency. Combustible or toxic vapors may be heavier than air, so the tests on the atmosphere must be run at least $\frac{3}{4}$ of the way down the manhole.

Whenever adverse atmosphere is encountered, forced ventilation must be used to create safe conditions. After the ventilating equipment has been operated for a few minutes, the atmosphere in the manhole should be retested before anyone enters the manhole.

When explosive conditions are encountered, the ventilating blower should be placed upwind to prevent igniting any gas that is emerging from the opening. When a gasoline engine blower is used, it must be located so that exhaust fumes cannot enter the manhole.

If testing equipment is not available, the manhole should be assumed to contain an unsafe atmosphere and forced ventilation must be provided. It should never be assumed that a manhole is safe just because there is no odor or the manhole has been entered previously.

B.4 Entering Manholes

Since the top of the manhole is usually flush with the surrounding surface, there may not be anything for the person who is entering the manhole to grab on to steady himself. Persons who are entering manholes should not be permitted to carry anything in their hands as they enter the manhole, to ensure that their hands will be free to hold on or grab if they slip. A good method for entering a manhole is to sit on the surface facing the manhole steps or ladder, with the feet in the hole and the arms straddling the opening for support. As the body slides forward and downward, the feet can engage a rung, and the back can rest against the opposite side of the opening. If there is any doubt about the soundness of the manhole steps, a portable ladder should be used.

A person should never enter a manhole unless he is wearing personal safety equipment, including a safety harness and a hard hat. Two persons should be stationed at the surface continuously while anyone is working inside a manhole, to lift him out if he is overcome or injured. One man cannot lift an unconscious man out of a manhole.

The persons stationed at the surface should also function as guards to keep people and vehicles away from the manhole opening. To avoid a serious injury, a person should not be lifted out of manhole by his arm unless it is a dire emergency.

When more than one person must enter a manhole, the first person should reach the bottom and step off the ladder before the next one starts down. When two men climb at the same time, the upper one can cause the lower one to fall by slipping or stepping on his fingers.

B.4.1 Traffic Protection

In addition to traffic cones, markers, warning signs, and barricades, a vehicle or a heavy piece of equipment should be placed between the working area and oncoming traffic. Flashing warning signals should be used to alert drivers and pedestrians. Orange safety vests should be worn by personnel stationed at the surface when the manhole is located in a vehicular traffic area.

B.4.2 Removing the Covers

Manhole covers should be removed with a properly designed hook. Use of a pick ax, screwdriver, or small pry bar may result in injury. A suitable tool can be made from $\frac{3}{4}$ -inch round or hex stock. Two inches of one end should be bent at a right angle and the other end should be formed into a D-handle wide enough to accommodate both hands. Even with this tool, care must be exercised to prevent the cover from being dropped on the toes. The 2-inch projection should be inserted into one of the holes in the cover, the handle grasped with both hands, and the cover lifted by straightening the legs which have been slightly bent at the knees.

B.4.3 Other Precautions

Other precautions which should be taken when entering a manhole are:

- Wear a hard hat.
- Wear coveralls or removable outer garment that can be readily removed when the work is completed.
- Wear boots or nonsparking safety shoes.
- Wear rubberized or waterproof gloves.
- Wear a safety harness with a stout rope attached.
- Do not smoke.
- Avoid touching yourself above the collar until you have cleaned your hands.

B.4.4 Emergencies

Every member of the crew should be instructed on procedures to be followed in cases of an emergency. It is the duty of each crew chief to have a list of emergency phone numbers, including the nearest hospital and ambulance service, police precinct, fire station, and rescue or general emergency number.

B.4.5 Field Equipment

The following equipment should be available for use:

Blowers	Gloves
Breathing apparatus	Hard Hats
Coverall	Harnesses
First aid kits	Manhole irons
Emergency flashers	Pick axes
Flashlight	Rain slickers
Mirror	Ropes
Gas detectors	Safety vests
Gas masks	Traffic cones
Waders	

B.5 Lethal Atmospheres in Sewers

The following is an article written by Dr. Richard D. Pomeroy, and published in the October 1980 issue of "Deeds & Data" of the WPCF. Dr. Pomeroy is particularly well known for his studies, over a period of nearly 50 years, in the field of the control of hydrogen sulfide and other odors in sewers and treatment plants. He has personally worked in a great many functioning sewers. In the earlier years he did so, he admits, with little knowledge of the grave hazards to which he exposed himself.

"It is gratifying that the subject of hazards to people working in sewers is receiving much more attention than in past years, and good safety procedures are prescribed in various publications on this subject. It is essential that people know and use correct procedures.

"It is less important to know just what the hazardous components of sewer atmospheres are, as safety precautions should in general be broadly applicable, but there should be a reasonable understanding of this subject. It is disturbing to see statements in print that do not reflect true conditions.

"One of the most common errors is the assumption that people have died from a lack of oxygen. The human body is able to function very well with substantially reduced oxygen concentrations. No one worries about going to Santa Fe, New Mexico, (elev. 2,100 meters), where the partial pressure of oxygen is equal to 16.2% (a normal atmosphere is about 21%) oxygen. "When first going there, a person may experience a little 'shortness of breath' following exercise.

"People in good health are not afraid to drive over the high passes in the Rocky Mountains. At Loveland Pass, oxygen pressure is 13.2% of a normal atmosphere. At the top of Mt.

Whitney, oxygen is equal to 12.2%. Many hikers go there, and to higher peaks as well. After adequate acclimation, they may climb to the top of Mt. Everest, where oxygen is equal to only 6.7%.

“The lowest oxygen concentrations that I have observed in a sewer atmosphere was 13 percent. It was in a sealed chamber, near sea level, upstream from an inverted siphon on a metropolitan trunk. A man would be foolish to enter the chamber. Without ventilation, he might die, but not from lack of oxygen.

“It seems unlikely that anyone has ever died in a sewer from suffocation, that is, a lack of oxygen. Deaths have often been attributed to ‘asphyxiation.’ This is a word which, according to the dictionary, is used to mean death from an atmosphere that does not support life. The word has sometimes been misinterpreted as meaning suffocation, which is only one kind of asphyxiation.

“In nearly all cases of death in sewers, the real killer is hydrogen sulfide. It is important that this fact be recognized. Many cities diligently test for explosive gases, which is very important, and they may measure the oxygen concentration which usually is unimportant, but they rarely measure H₂S. Death has occurred where it is unlikely that there was any measurable reduction in the oxygen concentration. Waste water containing 2 mg per liter of dissolved sulfide, and at a pH of 7.0, can produce, in a chamber with high turbulence, a concentration of 300 PPM H₂S, in the air. This is considered to be a lethal concentration. Many people have died from H₂S, not only in sewers and industries, but also from swamps and from hot springs. In one resort area, at least five persons died from H₂S poisoning before the people were ready to admit that H₂S is not a therapeutic agent. Hardly a year passes in the US. without a sewer fatality from H₂S as well as deaths elsewhere in the world.

“The presence of H₂S in a sewer atmosphere is easily determined. A bellows-and-ampoule type of tester is very satisfactory for the purpose, even though it is only crudely quantitative. When using a tester of this type, do not bring the air to the ampoule by way of a tube, as this may change the H₂S concentration. Hang the ampoule in the air to be tested, with a suction tube to the bulb or bellows.

“Lead acetate paper is very useful as a qualitative indicator. It cannot be used to estimate the amount of sulfide, but it will quickly turn black in an atmosphere containing only a tenth of a lethal concentration.

“Electrodes or other similar electrical indicating devices for H₂S in air have been marketed. Some of them are known to be unreliable, and we know of none that have proved dependable. Do not use one unless you check it at frequent intervals against air containing known H₂S concentra-

tions. A supposed safety device that is unreliable is worse than none at all.

“Remember that the nose fails, too, when it comes to sensing dangerous concentrations of H₂S.

“Various other toxic gases have been mentioned in some publications. It is unlikely that any person has been asphyxiated in a sewer by any of those other gases, except possibly chlorine. The vapor of gasoline and other hydrocarbons is sometimes present in amounts that could cause discomfort and illness, but under that condition, the explosion hazard would be far more serious. The explosimeter tests, as well as the sense of smell, would warn of the danger. Pipelines in chemical plants might contain any number of harmful vapors. They, too, are sensed by smell and explosimeter tests if they get into the public sewer. Such occurrences are rare.

“The attempt to instill a sense of urgency about real hazards is diluted if a man is told to give attention to a long list of things that in fact are irrelevant.

“Be very careful to avoid high H₂S concentrations, flammable atmospheres, and hazards of physical injuries. Remember that much H₂S may be released by the stirring up of sludge in the bottom of a structure. Obey your senses in respect to irritating gases, such as chlorine (unconsciousness comes suddenly from breathing too much). Be cautious about strange odors. Do not determine percent oxygen in the air. There is a danger that the result will influence a man's thinking about the seriousness of the real hazards. Most important, use ample ventilation, and do not enter a potentially hazardous structure except in a good safety harness with two men at the top who can lift you out.”

Table B-1 Hazardous Gases

Gas	Chemical Formula	Common Properties	Specific Gravity or Vapor Density Air = 1	Physiological Effect*	Max Safe 60 Min. Exposure ppm	Max. Safe 8 Hour Exposure ppm	Explosive Range (% by vol. in air.) Limits lower/upper	Likely Location of Highest Concentration	Most Common Sources	Simplest and Cheapest Safe Method of Testing
Ammonia	NH ₃	Irritant and poisonous. Colorless with characteristic odor.	0.60	Causes throat and eye irritation at 0.05%, coughing at 0.17%. Short exposure at 0.5% to 1% fatal.	300 to 500	85	16 to 25	Near top. Concentrates in closed upper spaces	Sewers, chemical feed rooms	Detectable odor at low concentrations
Benzene	C ₆ H ₆	Irritant, colorless anesthetic	2.77	Slight symptoms after several hours exposure at 0.16% to 0.32%. 2% rapidly fatal.	3,000 to 5,000	25	1.3 to 7.1	At bottom	Industrial wastes, varnish, solvents	Combustible gas indicator
Carbon Bisulfide	CS ₂	Nearly odorless when pure, colorless, anesthetic. Poisonous.	2.64	Very poisonous, irritating, vomiting, convulsions, psychic disturbance.	—	15	1.3 to 44.0	At bottom	An insecticide	Combustible gas indicator

Table B-1 Hazardous Gases (Continued)

Gas	Chemical Formula	Common Properties	Specific Gravity or Vapor Density Air = 1	Physiological Effect*	Max Safe 60 Min. Exposure ppm	Max. Safe 8 Hour Exposure ppm	Explosive Range (% by vol. in air.) Limits lower/upper	Likely Location of Highest Concentration	Most Common Sources	Simplest and Cheapest Safe Method of Testing
Carbon Dioxide	CO ₂	Asphyxiant, Colorless, odorless. When breathed in large quantities, may cause acid taste. Non-flammable. Not generally present in dangerous amounts unless an oxygen deficiency exists.	1.53	Cannot be endured at 10% more than a few minutes, even if subject is at rest and oxygen content is normal. Acts on respiratory nerves.	40,000 to 60,000	5,000	— —	At bottom; when heated may stratify at points above bottom.	Products of combustion, sewer gas, sludge. Also issues from carbonaceous strata.	Oxygen deficiency indicator
Carbon Monoxide	CO	Chemical asphyxiant. Colorless, odorless, tasteless. Flammable. Poisonous.	0.97	Combines with hemoglobin of blood. Unconsciousness in 30 min. at 0.2% to 0.25%. Fatal in 4 hours at 0.1%. Headache in few hours at 0.02%.	400	50	12.5 74.0	Near top, especially if present with illuminating gas.	Manufactured gas, flue gas, products of combustion, motor exhausts. Fires of almost any kind.	CO ampoules
Carbon Tetra-Chloride	CCl ₄	Heavy, ethereal odor.	5.3	Intestinal upset, loss of consciousness, possible renal damage, respiratory failure.	1,000 to 1,500	100	— —	At bottom.	Industrial wastes, solvent, cleaning	Detectable odor at low concentrations
Chlorine	Cl ₂	Irritant. Yellow-green color. Choking odor detectable in very low concentrations. Non-flammable.	2.49	Irritates respiratory tract. Kills most animals in a very short time at 0.1%.	4	1	— —	At bottom.	Chlorine cylinder and feed line leaks	Detectable odor at low concentrations
Formaldehyde	CH ₂ O	Colorless, pungent suffocating odor.	1.07	Irritating to the nose.	—	10	7.0 73.0	Near bottom	Incomplete combustion of organics. Common air pollutant, fungicide.	Detectable odor
Gasoline	C ₈ H ₁₂ to C ₉ H ₂₀	Volatile solvent. Colorless. Odor noticeable at 0.03%. Flammable.	3.0 to 4.0	Anesthetic effects when inhaled. Rapidly fatal at 2.4%. Dangerous for short exposure at 1.1 to 2.2%.	4,000 to 7,000	1,000	1.3 6.0	At bottom	Service stations, garages, storage tanks, houses.	1. Combustible gas indicator. 2. Oxygen deficiency indicator.**
Hydrogen	H ₂	Simple asphyxiant. Colorless, odorless, tasteless. Flammable	0.07	Acts mechanically to deprive tissues of oxygen. Does not support life.	—	—	4.0 74.0	At top	Manufactured gas, sludge digestion tank gas, electrolysis of water. Rarely from rock strata.	Combustible gas indicator
Hydrogen Cyanide	HCN	Faint odor of bitter almonds. Colorless gas	0.93	Slight symptoms appear upon exposure to 0.002% to 0.004%. 0.3% rapidly fatal.	—	10	6.0 40.0	Near top	Insecticide and rodenticide	Detector tube
Hydrogen Sulfide	H ₂ S	Irritant and poisonous volatile compound. Rotten egg odor in small concentrations. Exposure for 2 to 15 min. at 0.01% impairs sense of smell. Odor not evident at high concentrations. Colorless. Flammable.	1.19	Impairs sense of smell, rapidly as concentration increases. Death in few minutes at 0.2%. Exposure to 0.07 to 0.1% rapidly causes acute poisoning. Paralyzes respiratory center.	200 to 300	20	4.3 45.0	Near bottom, but may be above bottom if air is heated and highly humid.	Coal gas, petroleum, sewer gas. Fumes from blasting under some conditions. Sludge gas.	1. H ₂ S Ampoule. 2. 5% by weight lead acetate solution.
Methane	CH ₄	Simple asphyxiant. Colorless, odorless, tasteless, flammable.	0.55	Acts mechanically to deprive tissues of oxygen. Does not support life.	Probably no limit, provided oxygen percent-age is sufficient for life.	—	5.0 15.0	At top, increasing to certain depth.	Natural gas, sludge gas, manufactured gas, sewer gas. Strata of sedimentary origin. In swamps or marshes.	1. Combustible gas indicator 2. Oxygen deficiency indicator.
Nitrogen	N ₂	Simple asphyxiant. Colorless, tasteless. Non-flammable. Principal constituent of air. (about 79%).	0.97	Physiologically inert.	—	—	— —	Near top, but may be found near bottom.	Sewer gas, sludge gas. Also issues from some rock strata.	Oxygen deficiency indicator

Table B-1 Hazardous Gases (Continued)

Gas	Chemical Formula	Common Properties	Specific Gravity or Vapor Density Air = 1	Physiological Effect*	Max Safe 60 Min. Exposure ppm	Max. Safe 8 Hour Exposure ppm	Explosive Range (% by vol. in air.) Limits lower/upper	Likely Location of Highest Concentration	Most Common Sources	Simplest and Cheapest Safe Method of Testing
Nitrogen Oxides	NO	Colorless	1.04	60 to 150 ppm cause irritation and coughing.	50	10	— —	Near bottom	Industrial wastes. Common air pollutant.	NO ₂ detector tube
	N ₂ O	Colorless, sweet odor.	1.53	Asphyxiant.						
	NO ₂	Reddish-brown. Irritating odor. Deadly poison	1.58	100 ppm dangerous. 200 ppm fatal.						
Oxygen	O ₂	Colorless, odorless, tasteless. Supports combustion.	1.11	Normal air contains 20.8% of O ₂ . Man can tolerate down to 12%. Minimum safe 8 hour exposure, 14 to 16%. Below 10%, dangerous to life. Below 5 to 7% probably fatal.	—	—	— —	Variable at different levels.	Oxygen depletion from poor ventilation and absorption, or chemical consumption of oxygen.	Oxygen deficiency indicator
Ozone	O ₃	Irritant and poisonous. Strong electrical odor. Strong oxidizer. Colorless. At 1 ppm, strong sulfur-like odor.	1.66	Max. naturally occurring level is 0.04 ppm. 0.05 ppm causes irritation of eyes and nose. 1 to 10 ppm causes headache, nausea; can cause coma. Symptoms similar to radiation damage.	0.08	0.04	— —	Near bottom	Where ozone is used for disinfection	Detectable odor at 0.015 ppm
Sludge Gas	—***	Mostly a simple asphyxiant. May be practically odorless, tasteless.	Variable	Will not support life.	No data. Would vary widely with composition.		5.3 19.3	Near top of structure	From digestion of sludge	See components
Sulfur Dioxide	SO ₂	Colorless, pungent odor. Suffocating, corrosive, poisonous, non-flammable.	2.26	Inflammation of the eyes. 400 to 500 ppm immediately fatal.	50 to 100	10	— —	At bottom, can combine with water to form sulfurous acid.	Industrial waste, combustion, common air pollutant.	Detectable taste and odor at low concentration
Toluene	C ₆ H ₁₂ to C ₉ H ₂₀	Colorless, benzene-like odor.	3.14	At 200-500 ppm, headache, nausea, bad taste, lassitude.	200	100	1.27 7.0	At bottom	Solvent	Combustible gas indicator
Turpentine	C ₁₀ H ₁₆	Colorless, Characteristic odor.	4.84	Eye irritation. Headache, dizziness, nausea, irritation of the kidneys.	—	100		At bottom.	Solvent, used in paint	1. Detectable odor at low concentrations. 2. Combustible gas indicator.
Xylene	C ₈ H ₁₀	Colorless, flammable	3.66	Narcotic in high concentrations. less toxic than benzene.	—	100	1.1 7.0	At bottom	Solvent	Combustible gas indicator

* Percentages shown represent volume of gas in air.
 ** For concentration over 0.3%.
 ***Mostly methane and carbon dioxide with small amounts of hydrogen, nitrogen, hydrogen sulfide, and oxygen; occasionally traces of carbon monoxide.

Isco 4700 Refrigerated Sampler

Index

Numerics

24-hour time format, 3-3
3-way valve control output, 3-8

A

accurate volumes
 liquid detector, 3-6
 pump inspection, 5-1
 pump tube condition, 3-9
 specifications, 1-5
 suction line length, 3-5
air flow, refrigeration efficiency, 2-3
alarms
 configuring outputs, 3-8
 connection instructions, 2-14
 resetting pump tube warning, 5-5
 specifications, 1-5
analog input, 3-20
average temperature summary, 4-4

B

baud rate, 4-5
bottle
 1 bottle kit installation, 2-9
 2 bottle kit installation, 2.5 gal, 2-8
 24 bottle kit installation, 2-6
 4 bottle kit installation, 2-8
 available configurations, 1-4
 configuration kits, 2-4
 configuring custom software, 3-4
 configuring standard software, 3-4
 description and location, 1-3
 number of samples per bottle, 3-19
 overflow detection, 3-20
 removing full bottles, 4-7
 retaining ring, 350 ml glass bottles, 2-6
 switching bottle sets, 3-18
bottle full
 alarm output, 3-8
bottle locating base - 4, 2, and 1 bottles
 description and location, 1-3
 installation, 2-8, 2-9
bottle rack, 24 bottles, 2-6, 4-7
bottle-per-sample distribution, 3-18
button descriptions, 3-1

C

calibrate

 button, 3-2
 how to, 4-8
cancel button, 3-2
clock, internal
 last set report, 4-4
 setting time and date, 3-3
communications
 cable, 4-5
 software, 4-5
completed program, 4-2
composite sampling, 1-1, 3-21
configure instructions
 bottle kits, 2-4
 software, 3-3
connecting external devices, 2-14
 connector location, 1-3
 input signal specifications, 1-5
 list of inputs and outputs, 2-16
 other device connections, 2-15
 quick disconnect box, 2-15
 standard Isco instruments, 2-14
constant time variable volume, 3-20, 3-28
constant volume variable time, 1-1, 3-15
construction material, 1-4
contact Teledyne Isco, A-1
continuous operation
 composite bottle, 3-21
 multiple bottle, 3-19
control panel
 button descriptions, 3-1
 cover, 1-3
 description and location, 1-3
CPVC strainer, 2-12
cross-contamination, preventing, 2-6
CSV temperature data, 4-6
CTVV sampling mode, 3-20, 3-28
CVVT sampling mode, 1-1, 3-15

D

date
 format, 3-3
 setting time and date, 3-3
defining sample volumes, 3-23
delay before sample
 alarm output, 3-9
delayed start time, 4-1
delayed start times, 3-22
delimited temperature data, 4-6
description of sampler, 1-1

- diagnostics, 5-6
 - diagrams
 - bottles per sample, 3-18
 - flow paced sampler programming, 3-14
 - measure suction head height, 3-21
 - multiple bottle compositing, 3-19
 - samples per bottle, 3-19
 - suction line length, 3-6
 - time paced sampler programming, 3-13
 - views of sampler, 1-2
 - dimensions, 1-4
 - space requirements, 2-3
 - strainers, 2-12
 - disable sampler operation, 3-7
 - discharge tube
 - description and location, 1-3
 - installing, 2-5
 - slope required, 2-6
 - disconnect device, electrical, 1-3
 - distribution
 - bottle switch time, 3-18
 - bottle switching, 3-18
 - bottles per sample event, 3-18
 - continuous, 3-19
 - multiple bottle compositing, 3-19
 - samples per bottle, 3-19
 - switching bottles, 3-18
 - distributor arm
 - description and location, 1-3
 - installation, 2-5
 - preventing failure, 2-6
 - removing bottles, 4-7
 - distributor jammed alarm output, 3-8
 - down/right button, 3-2
- E**
- electrical - *see* 'power'
 - enable pin
 - configure options, 3-7
 - connection instructions, 2-14
 - enclosure rating, 1-5
 - enter button, 3-2
 - error message table, 4-5
 - 'errors have occurred' message, 4-2
 - event mark, 2-14
 - examples, programming, 3-22
 - exit button, 3-2
 - external device connections, 2-14
 - description, 1-3
 - input signal specifications, 1-5
 - list of inputs and outputs, 2-16
 - other device connections, 2-15
 - quick disconnect box, 2-15
 - standard Isco instruments, 2-14
- F**
- features, 1-2
 - FEP-lined suction line, 2-10
 - fill button, 3-23
 - first sample at, 3-22
 - first sample option, flow mode, 3-6
 - first valid day, 3-22
 - flow chart
 - flow-paced programming, 3-14
 - time-paced programming, 3-13
 - flow mode sampling, options, 3-6
 - flow pacing, 1-1
 - flow pacing interval, 3-15
 - flow pulses
 - calculations, 3-16
 - Isco flow meters, 3-15
 - program option, 3-20
 - flow-proportional sample volumes, 3-20
- G**
- grab sample
 - button, 3-2
 - how to, 4-8
 - graduated cylinder, 4-9
- H**
- halt, program, 4-3
 - hardware revision, 3-11, 4-4
 - head height, maximum, 1-4
 - HyperTerminal, 4-5
- I**
- identification of main components, 1-2
 - IDs, viewing, 3-11, 4-4
 - input, external device
 - how to, 2-14
 - signal specifications, 1-5
 - installation steps, 2-1
- K**
- key (button) descriptions, 3-1
- L**
- language
 - selection, 3-11
 - translation revision, 4-4
 - latch, refrigerator door, 1-3
 - latched/unlatched sampler enable, 3-7
 - level adjustment, 1-3
 - lifting the sampler, 1-3
 - line cord, AC power, 1-3
 - liquid detector
 - configure options, 3-6
 - description and location, 1-3
 - specification, 1-4
 - locating base - 4, 2, and 1 bottles
 - description and location, 1-3
 - installation, 2-8, 2-9
 - location, site considerations, 2-1
 - locking the sampler, 1-3, 2-18, 3-10

- log, 4-3
- low flow strainer, 2-12
- M**
- main menu display, 3-2
- mains power cord, 1-3
- maintenance, 5-1
- manual grab samples, 4-8
- manual pump operation, 4-9
- manual sample button, 3-2
- manual sample volume definition, 3-23
- material, construction, 1-4
- maximum run time, 3-22
- maximum suction lift height, 1-4
- memory type, 1-5
- military time, 3-3
- missed samples, 4-3, 4-4
- multiple bottle compositing, 3-19
- N**
- next button, 3-2
- 'no liquid detected' message, 4-5
- 'no more liquid' message, 4-5
- 'not enough flow' message, 4-5
- number buttons, 3-1
- O**
- on/off, 3-1
- operating temperature specification, 1-4
- output pin configure options, 3-8
- overflow detection, bottle, 3-20
- overview of sampler, 1-1
- P**
- pacing
 - constant volume variable time, 1-1
 - flow, 1-1
 - modes, 1-5
 - programming options, 3-15
 - specifications, 1-5
 - time, 1-1
- parameter-enabled sampling, 3-7
- parity, 4-5
- parts, A-1
- periodic maintenance, 5-1
- phenol content, vinyl suction line, 2-10
- positioning the sampler, 2-1
- power
 - backup, 2-17
 - connecting power, 2-17
 - field conversion, 2-17
 - line cord, 1-3
 - lost (log), 4-4
 - outlet plugs, 2-17
 - requirements, Foreword-v, 1-4
- 'power failed' message, 4-5
- powered up
 - alarm output, 3-8
 - pressurized line sampling, 3-8
 - previous button, 3-2
 - 'probable overflow' message, 4-5
- program
 - completed, 4-2, 4-4
 - delayed start, 4-1
 - disabled, 4-2
 - done, 4-2
 - halt, 4-3, 4-4
 - pause, 4-3, 4-4
 - resume, 4-3
 - starting, 4-1
 - stop, 4-3
- 'program halted' message, 4-5
- program lock
 - configure options, 3-10
 - general security, 2-18
- 'program paused' message, 4-5
- program started/completed alarm output, 3-8
- programming
 - examples, 3-22
 - flow chart, 3-13, 3-14
 - how to, 3-15
- ProPak, 2-6
- pump
 - components, 5-2
 - description and location, 1-3
 - forward (fill) button, 3-1, 3-23
 - inspection, 5-1
 - manual operation, 4-9
 - reverse (purge) button, 3-1, 3-23
 - rotor and rollers, 5-3
 - safety interlock, 5-2
 - wetted parts, 5-5
- pump accuracy, 1-4
- pump error
 - alarm output, 3-8
- pump failure
 - alarm output, 3-8
 - inspection, 5-1
 - message, 4-5
- pump tube
 - inspection, 5-2
 - life, 1-4
 - replacement, 5-3
 - reset alarm, 5-5
 - setting pump count warning, 3-9
- pumping forward
 - alarm output, 3-8
- pumping reverse
 - alarm output, 3-8
- purge button, 3-23
- Q**
- quick cool refrigeration mode, 3-7
- quick disconnect box, 2-15

R

- refrigeration configure options, 3-7
- refrigerator assembly
 - description and location, 1-3
- refrigerator average temperature, 4-4
- refrigerator door, 1-3
- repair instructions
 - technical service department, 5-1
- repeatable volumes
 - liquid detector, 3-6
 - pump tube condition, 3-9
 - specification, 1-4
 - suction line length, 3-5
- replacement parts list, A-1
- reports
 - settings and results, 4-7
 - temperature, 4-5
- retaining ring, 350 ml glass bottles, 2-6
- retries, sample, 3-6
- rinse cycles, 3-6
- rotor and rollers, pump, 5-3
- RS-232
 - communication cable, 4-5
 - serial data, 2-16
- run continuously, 3-19
- run program button, 3-2
- run state displays, 4-2
- run time, maximum, 3-22
- running a program, 4-1

S

- safety, Foreword-v, B-1
- safety interlock, pump, 5-2
- sample at start flow mode option, 3-6
- sample event
 - causes, 3-12
 - sampler actions, 3-12
- sample start time, 3-22
- sample volume
 - specifications, 1-5
- samples per bottle, 3-19
- sampling retries, 3-6
- security
 - general instructions, 2-18
 - passwords, 3-10
- select days, 3-22
- sequential sampling, 1-1
- serial data communication, 2-16
- site considerations, 2-1
- software revision, 3-11, 4-4
- space requirements, 2-3
- specifications, 1-4
- standby button, 3-1
- start flow count at, 3-22
- start program button, 3-2
- start time delay, 3-22
- starting a program, 4-1
- start-up screen, 3-2

- stop bit, 4-5
- stop button, 3-2
- strainer
 - alternative, 2-13
 - CPVC, 2-12
 - installation instructions, 2-12
 - low flow, 2-12
 - maximum depths, unanchored, 2-13
 - placement in stream, 2-13
 - types of, 2-12
 - weighted, 2-12
- suction head, manually entered, 3-21
- suction line
 - configuring length, 3-5
 - cutting lengths, 2-10, 3-5
 - inside diameter, 1-4
 - installation overview, 2-10
 - installation recommendations, 2-3
 - installing FEP-lined suction lines, 2-11
 - installing vinyl suction lines, 2-11
 - material, 1-4
 - maximum lift, 1-4
 - pre-sample conditioning, 3-6
 - prevent freezing, 2-13
 - routing, 2-13
 - transport velocities, 1-1, 1-4
 - tubing length specification, 1-4
- switching bottles, 3-18
- system IDs, viewing, 3-11

T

- taking sample
 - alarm output, 3-8
- tamper-proof operation, 2-18
- technical service department, 5-1
- temperature
 - detailed log, 4-5
 - operating specification, 1-4
 - summary, 4-4
 - verification, 5-13
- terminal emulation, 4-5
- tests, hardware and software, 5-6
- 3-way valve control output, 3-8
- time formats, 3-3
- time pacing, 1-1
- time pacing interval, 3-15
- translation revision, 4-4
- transport velocities, 1-1, 1-4
- troubleshooting, 5-6
- tube, discharge, 1-3
- tubing life configure option, 3-9
- 24-hour time format, 3-3

U

- unpacking, 2-1
- up/left button, 3-2
- 'user stopped pump' message, 4-5

V

velocity, liquid transport, 1-1, 1-4
volume

- constant time variable volume, 3-20
- defining volume manually, 3-23
- enter sample volume, 3-19
- flow-proportional, 3-20
- manually defined volumes, 3-19
- repeatability, 1-4
- specifications, 1-5

volume accuracy, 1-4

W

'warning! change pump tube'

- log entry, 4-4
- reset alarm, 5-5
- setting warning interval, 3-9

weight (empty sampler), 1-4

weighted strainer, 2-12

wetted parts, 5-5

DECLARATION OF CONFORMITY

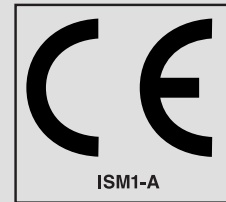

Application of Council Directive: 89/336/EEC – The EMC Directive
73/23/EEC – The Low Voltage Directive
Manufacturer's Name: Teledyne Isco, Inc.
Manufacturer's Address: 4700 Superior, Lincoln, Nebraska 68504 USA
Mailing Address: P.O. Box 82531, Lincoln, NE 68501
Equipment Type/Environment: Laboratory Equipment for Light Industrial/Commercial Environments
Trade Name/Model No: 4700 Refrigerated Sampler
Year of Issue: 2006

Standards to which Conformity is Declared: EN 61010-1 Safety Requirements for Electrical Equipment for Measurement, Control, and Laboratory Use
EN 61326:1998 EMC Requirements for Electrical Equipment for Measurement, Control, and Laboratory Use
EN60529 Degrees of Protection Provided by the Enclosure IP-25

Standard	Description	Severity Applied	Performance Criteria
EN61000-4-2	Electrostatic Discharge	Level 2 - 4kV contact discharge Level 3 - 8kV air discharge	A
EN61000-4-3	Radiated RF Immunity	80 MHz to 1000MHz 80% AM at 1kHz Level 1 – 10V/m	A
EN61000-4-4	Electrical Fast Transient	Level 2 – 2kV on AC lines	A
EN61000-4-5	Surge on AC Lines	2kV L-Gnd, 1KV L-L	A
EN61000-4-6	Conducted RF on AC lines	150 kHz to 80 MHz, 3V rms, 80% modulated	A
EN61000-4-11	AC Dips and Short Interruptions	0.5 Cycle, each polarity/100%	A
CISPR11/ EN 55011	RF Emissions	Group 1, Class A Industrial, Scientific, and Medical Equipment	
EN61000-3-2, 3-3	Harmonic, Flicker		

We, the undersigned, hereby declare that the design of the equipment specified above conforms to the above Directive(s) and Standards as of August 2, 2006

William Foster
USA Representative



William Foster
Director of Engineering
Teledyne Isco, Inc.
4700 Superior Street
Lincoln, Nebraska 68504

Phone: (402) 464-0231
Fax: (402) 464-4543

60-4702-030
Rev A

产品中有毒有害物质或元素的名称及含量

Name and amount of Hazardous Substances or Elements in the product

部件名称 Component Name	有毒有害物质或元素 Hazardous Substances or Elements					
	铅 (Pb)	汞 (Hg)	镉 (Cd)	六价铬 (Cr(VI))	多溴联苯 (PBB)	多溴二联苯 (PBDE)
线路板 Circuit Boards	X	O	O	O	O	O
显示 Display	X	O	O	O	O	O
接线 Wiring	O	O	O	O	X	O
内部电缆 Internal Cables	O	O	O	O	X	O
压缩机 Compressor	O	O	O	O	X	O
绝缘，绝热 Insulation	O	O	O	O	X	O
绝缘泡沫 Insulation Foam	O	O	O	O	X	O
主电源线 Line Cord	O	O	O	O	X	O
电源 Power Supply	X	O	O	O	X	O
直流电机 DC Motor	X	O	O	O	X	O
小键盘 Keypad	O	O	O	O	X	O

产品中有毒有害物质或元素的名称及含量：Name and amount of Hazardous Substances or Elements in the product

O: 表示该有毒有害物质在该部件所有均质材料中的含量均在ST/ 标准规定的限量要求以下。

O: Represent the concentration of the hazardous substance in this component's any homogeneous pieces is lower than the ST/ standard limitation.

X: 表示该有毒有害物质至少在该部件的某一均质材料中的含量超出ST/ 标准规定的限量要求。

(企业可在此处，根据实际情况对上表中打“X”的技术原因进行进一步说明。)

X: Represent the concentration of the hazardous substance in this component's at least one homogeneous piece is higher than the ST/ standard limitation.

(Manufacturer may give technical reasons to the “X”marks)

环保使用期由经验确定。

The Environmentally Friendly Use Period (EFUP) was determined through experience.

生产日期被编码在系列号码中。前三位数字为生产年(207 代表 2007 年)。随后的一个字母代表月份：

A 为一月，B 为二月，等等。

The date of Manufacture is in code within the serial number. The first three numbers are the year of manufacture (207 is year 2007) followed by a letter for the month. "A" is January, "B" is February and so on.

Teledyne Isco One Year Limited Factory Service Warranty*

This warranty exclusively covers Teledyne Isco instruments, providing a one-year limited warranty covering parts and labor.

Any instrument that fails during the warranty period due to faulty parts or workmanship will be repaired at the factory at no charge to the customer. Teledyne Isco's exclusive liability is limited to repair or replacement of defective instruments. Teledyne Isco is not liable for consequential damages.

Teledyne Isco will pay surface transportation charges both ways within the 48 contiguous United States if the instrument proves to be defective within 30 days of shipment. Throughout the remainder of the warranty period, the customer will pay to return the instrument to Teledyne Isco, and Teledyne Isco will pay surface transportation to return the repaired instrument to the customer. Teledyne Isco will not pay air freight or customer's packing and crating charges. This warranty does not cover loss, damage, or defects resulting from transportation between the customer's facility and the repair facility.

The warranty for any instrument is the one in effect on date of shipment. The warranty period begins on the shipping date, unless Teledyne Isco agrees in writing to a different date.

Excluded from this warranty are normal wear; expendable items such as charts, ribbon, lamps, tubing, and glassware; fittings and wetted parts of valves; and damage due to corrosion, misuse, accident, or lack of proper maintenance. This warranty does not cover products not sold under the Teledyne Isco trademark or for which any other warranty is specifically stated.

No item may be returned for warranty service without a return authorization number issued by Teledyne Isco.

This warranty is expressly in lieu of all other warranties and obligations and Teledyne Isco specifically disclaims any warranty of merchantability or fitness for a particular purpose.

The warrantor is Teledyne Isco, 4700 Superior, Lincoln, NE 68504, U.S.A.

*** This warranty applies to the USA and countries where Teledyne Isco does not have an authorized dealer. Customers in countries outside the USA, where Teledyne Isco has an authorized dealer, should contact their Teledyne Isco dealer for warranty service.**

Before returning any instrument for repair, please call, fax, or e-mail the Teledyne Isco Service Department for instructions. Many problems can often be diagnosed and corrected over the phone, or by e-mail, without returning the instrument to the factory.

Instruments needing factory repair should be packed carefully, and shipped to the attention of the service department. Small, non-fragile items can be sent by insured parcel post. **PLEASE BE SURE TO ENCLOSE A NOTE EXPLAINING THE PROBLEM.**

Shipping Address: Teledyne Isco - Attention Repair Service
4700 Superior Street
Lincoln, NE 68504 USA

Mailing Address: Teledyne Isco
PO Box 82531
Lincoln, NE 68501 USA

Phone: Repair service: (800) 775-2965 (lab instruments)
(866) 298-6174 (samplers & flow meters)
Sales & General Information: (800) 228-4373 (USA & Canada)

Fax: (402) 465-3001

Email: IscoService@teledyne.com



February 28, 2012 P/N 60-1002-040 Rev G

