

4250 Area Velocity Flow Meter

Installation and Operation Guide



Part #60-3253-042 of Assembly #60-3254-012
Copyright © 1994. All rights reserved, Teledyne Isco
Revision BB, October 11, 2013

Foreword

This instruction manual is designed to help you gain a thorough understanding of the operation of the equipment. Teledyne Isco recommends that you read this manual completely before placing the equipment in service.

Although Teledyne Isco designs reliability into all equipment, there is always the possibility of a malfunction. This manual may help in diagnosing and repairing the malfunction.

If the problem persists, call or e-mail the Teledyne Isco Technical Service Department for assistance. Simple difficulties can often be diagnosed over the phone.

If it is necessary to return the equipment to the factory for service, please follow the shipping instructions provided by the Customer Service Department, including the use of the **Return Authorization Number** specified. **Be sure to include a note describing the malfunction.** This will aid in the prompt repair and return of the equipment.

Teledyne Isco welcomes suggestions that would improve the information presented in this manual or enhance the operation of the equipment itself.

Teledyne Isco is continually improving its products and reserves the right to change product specifications, replacement parts, schematics, and instructions without notice.

Contact Information

Customer Service

Phone: (800) 228-4373 (USA, Canada, Mexico)
(402) 464-0231 (Outside North America)
Fax: (402) 465-3022
Email: IscoCSR@teledyne.com

Technical Support

Phone: Toll Free (866) 298-6174 (Samplers and Flow Meters)
Toll Free (800) 775-2965 (Syringe Pumps and Liquid Chromatography)

Email: IscoService@teledyne.com

Return equipment to: 4700 Superior Street, Lincoln, NE 68504-1398

Other Correspondence

Mail to: P.O. Box 82531, Lincoln, NE 68501-2531
Email: IscoInfo@teledyne.com

General Warnings

Before installing, operating, or maintaining this equipment, it is imperative that all hazards and preventive measures are fully understood. For information about general safety practices, turn to Appendix C *General Safety Procedures*. While specific hazards may vary according to location and application, take heed of the following general warnings:

 **WARNING**

Avoid hazardous practices! If you use this instrument in any way not specified in this manual, the protection provided by the instrument may be impaired.

 **AVERTISSEMENT**

Éviter les usages périlleux! Si vous utilisez cet instrument d'une manière autre que celles qui sont spécifiées dans ce manuel, la protection fournie de l'instrument peut être affaiblie; cela augmentera votre risque de blessure.

Hazard Severity Levels

This manual applies *Hazard Severity Levels* to the safety alerts. These three levels are described in the sample alerts below.

 **CAUTION**

Cautions identify a potential hazard, which if not avoided, may result in minor or moderate injury. This category can also warn you of unsafe practices, or conditions that may cause property damage.

 **WARNING**









Warnings identify a potentially hazardous condition, which if not avoided, could result in death or serious injury.

 **DANGER**

DANGER – limited to the most extreme situations to identify an imminent hazard, which if not avoided, will result in death or serious injury.

Hazard Symbols

The equipment and this manual use symbols used to warn of hazards. The symbols are explained below.

Hazard Symbols	
Warnings and Cautions	
	The exclamation point within the triangle is a warning sign alerting you of important instructions in the instrument's technical reference manual.
	The lightning flash and arrowhead within the triangle is a warning sign alerting you of "dangerous voltage" inside the product.
Symboles de sécurité	
	Ce symbole signale l'existence d'instructions importantes relatives au produit dans ce manuel.
	Ce symbole signale la présence d'un danger d'électocution.
Warnungen und Vorsichtshinweise	
	Das Ausrufezeichen in Dreieck ist ein Warnzeichen, das Sie darauf aufmerksam macht, daß wichtige Anleitungen zu diesem Handbuch gehören.
	Der gepfeilte Blitz im Dreieck ist ein Warnzeichen, das Sie vor "gefährlichen Spannungen" im Inneren des Produkts warnt.
Advertencias y Precauciones	
	Esta señal le advierte sobre la importancia de las instrucciones del manual que acompañan a este producto.
	Esta señal alerta sobre la presencia de alto voltaje en el interior del producto.

4250 Flow Meter

Table of Contents

Section 1 Introduction

1.1 Description	1-2
1.2 Compatible Equipment	1-2
1.3 Flow Meter Operation	1-3
1.4 Area Velocity Sensor Operation	1-3
1.4.1 Velocity Measurement	1-3
1.4.2 Pressure Transducer Operation	1-4
1.5 Three Sensors Available	1-4
1.6 Software Upgrades	1-6
1.7 Controls, Indicators, and Connectors	1-6
1.8 Technical Specifications	1-6
1.9 How to Make Battery Calculations	1-13
1.9.1 Calculating Current Draw	1-14

Section 2 Programming

2.1 Getting Started	2-1
2.1.1 Operation of the Display	2-1
2.1.2 Keypad Functions	2-2
2.2 Programming Procedure	2-3
2.3 Description of Program Steps	2-5
2.3.1 Step 1, Operating Mode	2-5
2.3.2 Step 2, Flow Conversion Type	2-5
2.3.3 Step 3 - Adjust Level, Parameters	2-7
2.3.4 Step 4 - Reset Totalizer	2-8
2.3.5 Step 5 - Sampler Pacing	2-9
2.3.6 Step 6 - Sampler Enable	2-9
2.3.7 Step 7 - Alarm Dialout Mode	2-10
2.3.8 Step 8 - Printer	2-10
2.3.9 Step 9 - Reports/History	2-11
2.4 Interpreting the Program Screens	2-11
2.4.1 Operating Mode	2-11
2.4.2 Optional Outputs	2-19
2.4.3 Step 1 - Program	2-28
2.4.4 Step 2 - Flow Conversion (Area Velocity Only)	2-33
2.4.5 Step 2 - Flow Conversion (Level-to-Flow Rate)	2-36
2.4.6 Step 3 - Parameter to Adjust	2-43
2.4.7 Step 4 - Reset Totalizer	2-49
2.4.8 Step 5 - Sampler Pacing	2-49
2.4.9 Step 6 - Sampler Enable	2-52
2.4.10 Step 7 - Alarm Dialout Mode	2-55
2.4.11 Step 8 - Printer	2-57
2.4.12 Step 9 - Reports/History	2-59
2.4.13 Flow Meter History Contents	2-61

Section 3 Installation

3.1 Preparation for Use	3-1
-----------------------------------	-----

3.1.1	Installing the Desiccant Canister	3-1
3.1.2	Installing the External Desiccant Cartridge	3-1
3.1.3	Opening the Case	3-3
3.2	Connection to a Power Source	3-3
3.2.1	Low Power Indication	3-3
3.2.2	Isco Sampler	3-3
3.2.3	Isco Nickel-Cadmium Battery	3-4
3.2.4	Isco Lead-Acid Battery	3-5
3.2.5	AC Power Supplies	3-5
3.2.6	External 12 Volt Direct Current Source	3-6
3.3	Flow Meter Mounting and Installation	3-7
3.3.1	Carrying Handle	3-7
3.3.2	Location of the Flow Meter	3-7
3.3.3	Mounting the 4250	3-7
3.3.4	Vent Hose to Desiccant Cartridge	3-8
3.4	Quick-Disconnect Box	3-9
3.5	Extension Cables	3-11
3.6	Area Velocity Sensor Installation	3-12
3.6.1	Level Measurement in Open Channels (No Primary Device)	3-13
3.7	Rectangular and Trapezoidal Channels	3-16
3.8	Mounting Rings for Circular Channels	3-16
3.8.1	Spring Rings	3-16
3.8.2	Scissors Rings	3-18
3.8.3	Completing the AV Sensor Installation	3-19
3.9	Sampler Interface	3-20

Section 4 Options and Accessories

4.1	4200T Modem	4-1
4.1.1	How it Works	4-1
4.1.2	Modems and Flowlink Software	4-2
4.1.3	Connection to a Telephone Line	4-2
4.1.4	Types of Service	4-3
4.2	Connection to External Serial Device	4-4
4.3	4-20 mA Analog Outputs: External and Internal	4-4
4.3.1	External 4-20 mA Output Interface	4-5
4.3.2	Internal Multiple Analog Output Board	4-6
4.4	Pacing Non-Isco Equipment	4-8
4.5	Tipping Bucket Rain Gauge	4-11
4.6	Isco Flowlink Software	4-12
4.7	High-Low Alarm Relay Box	4-12
4.7.1	Installation	4-13
4.7.2	Wiring to a 4200 Series Flow Meter	4-13
4.8	Parameter Sensing with Isco 4200 Series Flow Meters	4-13
4.8.1	Installation of Parameter Probes	4-13
4.9	Temperature Probe	4-14
4.10	pH Probe	4-15
4.10.1	pH Probe Calibration	4-17
4.10.2	pH Probe Installation Guidelines	4-18
4.10.3	Storage and Maintenance of pH Probes	4-20
4.11	Dissolved Oxygen (D.O.) Probe	4-21
4.11.1	How the D.O. Probe Works	4-22
4.11.2	Probe Preparation	4-23
4.11.3	Membrane Thicknesses	4-23
4.11.4	Probe Installation	4-24
4.11.5	Probe Operation and Precautions	4-24
4.11.6	Calibrating the D.O. Probe with a Flow Meter	4-26
4.12	Installation of Parameter Probes in Mounting Rings	4-27

4.13 The YSI 600 Multiple Parameter Sonde	4-27
4.14 Mechanical Totalizer	4-29

Section 5 Maintenance and Service

5.1 Routine Maintenance and Minor Service	5-1
5.1.1 Care of the Flow Meter Case	5-1
5.1.2 Care of the Case Seal	5-1
5.1.3 Preventing Moisture Damage	5-1
5.2 Reactivation of the Desiccators	5-2
5.2.1 When to Recharge the Desiccant in the Tubes	5-2
5.2.2 Regenerating the Desiccant Canister	5-3
5.3 Care of the AV Sensor and Cables	5-5
5.3.1 Low Maintenance	5-5
5.3.2 Cleaning the Standard AV Probe	5-5
5.3.3 Cleaning the Low Profile AV Probe	5-6
5.3.4 Cable Inspection	5-7
5.4 Maintenance of the Printer	5-8
5.4.1 Changing the Roll of Paper	5-8
5.4.2 Ink Ribbon Replacement	5-10
5.4.3 Do Not Disassemble or Lubricate the Printer	5-11
5.5 Servicing And Troubleshooting	5-11
5.5.1 Disassembling the Flow Meter	5-11
5.5.2 Fuse Replacement	5-12
5.5.3 Display Warnings	5-13
5.5.4 System Reset	5-13
5.6 Preliminary Troubleshooting Steps	5-14
5.6.1 If Serious Problems Occur	5-14
5.6.2 Inspection Protocol	5-14
5.7 Precautions for Servicing CMOS Circuitry	5-16
5.7.1 Hazard of Static Electricity	5-16
5.8 Software Updates	5-18
5.8.1 Updating the Flow Meter Software	5-18

Appendix A Replacement Parts and Accessories

A.1 Replacement Parts	A-1
A.2 Accessory/Options Parts List	A-6

Appendix B Programming Worksheets

B.1 Setup	B-1
B.2 Flow Conversion: Area Velocity	B-3
B.3 Flow Conversion: Level-to-Flow Rate	B-4
B.4 Parameter to Adjust	B-5
B.5 Reset Totalizer	B-6
B.6 Sampler Pacing	B-6
B.7 Sampler Enable	B-6
B.8 Alarm Dialout Mode	B-7
B.9 Printer	B-7
B.10 Reports/History	B-7

Appendix C General Safety Procedures

C.1 Practical Safety Precautions	C-1
C.2 Lethal Atmospheres in Sewers	C-4
C.3 Hazardous Gases	C-6

Appendix D Material Safety Data Sheets

D.1 Overview	D-1
------------------------	-----

List of Figures

1-1 The 4250 Area Velocity Flow Meter	1-1
1-2 Standard Area Velocity Probe	1-4
1-3 Low-Profile Area Velocity Probe	1-5
1-4 Operation of the Area Velocity Sensor	1-5
1-5 4250 Side View Showing Connectors and Pin Functions	1-7
1-6 Measuring Flow Meter Current	1-15
2-1 The YSI 600 Sonde	2-8
2-2 Measuring Minimum Depth	2-14
2-3 Measuring Offset Distance	2-15
2-4 Measuring Level in Round Pipes	2-44
2-5 YSI 600 Sonde Calibration Flow Chart	2-48
3-1 Battery Installed on Flow Meter	3-4
3-2 Power Pack Installed on Flow Meter	3-6
3-3 4250 Suspended by Handle (handles may vary)	3-8
3-4 Quick-Disconnect Box for the Area Velocity Sensor	3-9
3-5 Cable Connections in the Quick-Disconnect Box	3-10
3-6 Assembling a Compression Bushing	3-11
3-7 Methods of Level Measurement	3-15
3-8 Isco Rectangular Mounting Plate	3-16
3-9 Sensor Installed on a Spring Ring	3-17
3-10 Scissors Ring Adjustment	3-19
4-1 Type 'E' Interface for pacing non-Isco equipment	4-8
4-2 Flow meter with front panel removed	4-9
4-3 Removing the lower shield	4-10
4-4 Type 'E' modification	4-10
4-5 674 Tipping Bucket Rain Gauge	4-11
4-6 Temperature Probe	4-15
4-7 pH Probe (with protective cap)	4-16
4-8 pH Parameter Module	4-19
4-9 The D.O. Probe	4-22
4-10 D.O. Parameter Module	4-26
4-11 The YSI 600 Multiple Sensor Sonde	4-28
5-1 Location of the Desiccant Cartridge	5-3
5-2 Standard AV Probe with Mounting Plate	5-6
5-3 Standard AV Probe, Protective Disk Exposed	5-6
5-4 Low Profile AV Probe Without Mounting Plate	5-6
5-5 Low Profile Probe With Transducer Housing Revealed	5-7
5-6 Changing the Chart Paper	5-8
5-7 Changing the Ink Ribbon	5-10
5-8 Lifting the Flow Meter from the Case	5-12
5-9 Location of the Three Fuses	5-13
5-10 Open the software update program	5-18

List of Tables

1-1	4250 Controls, Indicators, and Connectors	1-8
1-2	4250 Technical Specifications	1-8
1-3	Technical Specifications for the Standard AV Sensor	1-10
1-4	Technical Specifications for the Low Profile AV Sensor	1-11
1-5	4250 Chart Longevity	1-12
1-6	Battery Life Expectancy	1-12
2-1	ASCII Output Codes	2-22
4-1	4-20 mA Output Interface Specifications	4-5
4-2	Multiple Analog Output Board Specifications	4-7
4-3	pH Probe Specifications	4-20
4-4	D.O. Probe Specifications	4-25
A-1	Replacement Parts List	A-4
C-1	Hazardous Gases	C-6

4250 Flow Meter

Section 1 Introduction

This section of the instruction manual provides a general introduction to the 4250 Area Velocity Flow Meter. It includes a description of the flow meter, an explanation of how the unit operates, and technical specifications.

Manual Organization – This manual provides the information necessary to operate, maintain, and perform minor service on the 4250. The manual is organized into five sections:

Section 1 – Introduction, operation, and specifications.

Section 2 – Keypad operation and programming for the flow meter.

Section 3 – Installation and options application-specific to the 4250

Section 4 – Options and accessories available for all 4200 Series Flow Meters

Section 5 – Routine maintenance and minor service

Following Section 5 are appendices covering replacement parts and accessories, programming worksheets, safety information, and material safety data sheets.



Figure 1-1 The 4250 Area Velocity Flow Meter

1.1 Description

The 4250 Area Velocity Flow Meter uses a sensor with two different sensor systems submerged in the flow stream. This probe is called the area-velocity (or AV) probe. It contains a pressure transducer to measure level and a pair of ultrasonic transducers to measure velocity. The flow meter then calculates flow based on the cross-sectional area of the flow stream and its velocity. You need only enter the dimensions of the flow channel. If you want, you can also use the 4250 with a primary measuring device, as it has built-in standard level-to-flow conversions that cover most open channel flow measurement situations. You can enter an equation, or sets of data points that plot a user-derived flow profile for a flow stream. You can enter either velocity data points or level/flow rate data points. The 4250 supports Flowlink, Teledyne Isco's data acquisition, storage, and retrieval software.

Using Flowlink, the 4250 has enough memory to store 40,000 data readings. The optional 4200T Modem with speech capability is available to transmit stored data over telephone lines.

1.2 Compatible Equipment

The 4250 Flow Meter may be used with the following equipment:

Manufactured by Teledyne Isco:

- 3700 Series Sequential, Composite and Refrigerated Samplers
- 6700 Series Portable and Refrigerated Samplers
- GLS Compact Portable Sampler
- 4-20 mA Output Interface
- Tipping Bucket Rain Gauge
- High-Low Alarm Relay Box

Non-Isco Equipment:

- IBM Personal Computer or compatible clone with Isco Flowlink software
- Laptop Computer with Isco software
- YSI 600 Multi-Parameter Sonde

Optional Accessories:

- 4200T Modem - Speech-capable, with connector and cable
- D.O. (dissolved oxygen), pH, and temperature parameter probes
- Extension Cable (Vented) for the AV sensor, length of 25 feet. (Maximum distance between sensor and flow meter with extension cables is 75 feet.)
- Quick-Disconnect Box for AV sensor (Increases maximum distance between flow meter and sensor to 1000 feet.)
- Isco Flowlink Software for data acquisition, storage, and management
- Mounting rings for the AV sensor

1.3 Flow Meter Operation

When measuring flow rate, the 4250 is normally used with an open channel and calculates flow rate from a combination of measured level, stream velocity, and channel cross-sectional area. This is the only method of flow measurement that can measure submerged, full pipe, surcharged, and reverse flows, and it renders a primary measuring device unnecessary. The flow meter provides standard or optional flow-related output signals to be used for:

- Flow-proportional sampler pacing and enabling
- Transmitting level and flow data to an external device on a serial communications loop
- Data transfer to a remote location through a modem
- Control of an external 4-20 mA device
- Data transfer by a laptop computer

The 4250 contains microprocessor-controlled circuitry to calculate level and flow rates from the output produced by the area-velocity sensor, store user programming instructions, operate the display, and drive the internal plotter. An alphanumeric liquid crystal display (LCD) shows current total flow, level, and flow rate information. It also prompts you during initial setup or subsequent program changes. An internal plotter provides a hard copy printout of the information computed, plots level or flow rate, and generates reports. Connectors for other equipment used with the 4250 are on the right side of the flow meter's case.

1.4 Area Velocity Sensor Operation

The AV sensor is mounted beneath the surface of the flow stream and measures liquid level by responding to changes in hydrostatic pressure against a solid state pressure transducer. It measures average velocity ultrasonically by using the **Doppler effect**. This principle states that the frequency of a sound (or other wave) passed from one body to another is relative to both their motions. As the two approach each other, the frequency increases; as they recede, the frequency decreases. The motion of the bodies relative to each other is added to or subtracted from the frequency of the wave. A familiar example is this: You are in a car at a railroad crossing waiting for a train. As the train approaches, it sounds its whistle in warning. The whistle sounds a certain pitch to you. As the train passes through the crossing, the pitch drops noticeably. The transmitted frequency, of course, is always the same, but the Doppler effect will make it seem higher or lower to you because of the movement of the train toward or away from you.

1.4.1 Velocity Measurement

The probe's ultrasonic transducer transmits a high-frequency pulse into the flow stream. Bubbles and particles carried by the stream reflect the pulse back to the receiving transducer. The reflected pulse will have a different frequency, depending on whether the bubbles or particles are moving away from or toward the sensor.

This frequency difference is converted by the flow meter into a velocity reading, and the reading can indicate either forward or reverse flow.

1.4.2 Pressure Transducer Operation

The pressure transducer in the area-velocity sensor contains a resistance bridge on a silicon diaphragm. Pressure against one side of this diaphragm causes it to flex slightly. The other side of the bridge is referenced through a small tube to atmospheric pressure. Flexing the chip causes the resistors on one side of the bridge to stretch, while the resistors on the other side compress. The result is an unbalance in the current across the bridge that is proportional to the increase in pressure caused by a rising level in the flow stream. This bridge is fed from a constant-voltage source, so any change in its output is a result of hydrostatic pressure against the transducer.

1.5 Three Sensors Available

Teledyne Isco offers three types of AV sensor for use with the 4250. The **10-foot standard** unit is intended for operation in depths from 1 inch to 10 feet maximum. The **30-foot standard** unit is capable of operation to depths as great as 30 feet. The difference is in the sensitivity of the pressure transducer used inside. The two are not interchangeable. You must select the appropriate unit based on the maximum anticipated depth in your flow stream.

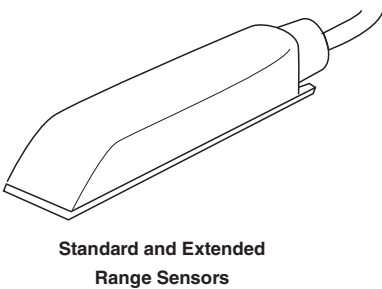
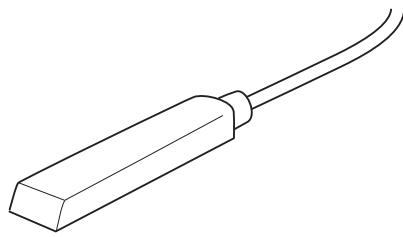

Figure 1-2 Standard Area Velocity Probe



Low Profile Sensor

The third type of area-velocity sensor is the low-profile probe. This probe is streamlined for use in shallow flows and small pipes, in depths as low as 1 inch (25 mm).

The area-velocity sensor is designed to avoid accumulating debris that could affect readings. In rare instances, however, debris may accumulate inside the opening containing the pressure transducer and cause it to give false readings. In such cases, you may need to remove the probe and clean it.



Figure 1-3 Low-Profile Area Velocity Probe

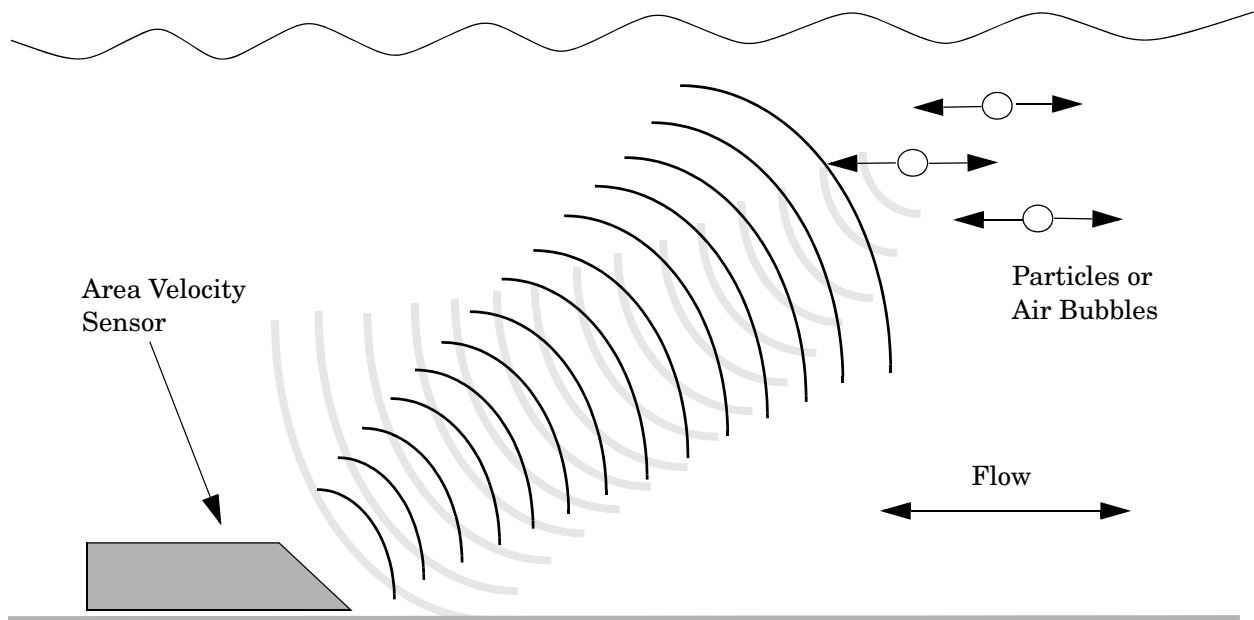

Figure 1-4 Operation of the Area Velocity Sensor

 **CAUTION**

If you disassemble the AV sensor for cleaning, do not touch the exposed metal diaphragm inside the probe with either tools or your fingers. The diaphragm is very fragile. Deforming it even slightly may place a permanent offset on the transducer, ruining it (and the rest of the sensor). Use only gently running water to clean the probe.

See Section 5 for information on cleaning the pressure transducer. The velocity sensing circuitry is sealed inside the housing and is not serviceable.

1.6 Software Upgrades

4200 Series Flow Meters can be upgraded without being returned to the factory or having the EPROM replaced. With Flash memory, software updates can easily be installed in the field with a disk, a computer, and a cable. Flash update instructions can be found in Section 5 Maintenance. For more information about installing software upgrades in the 4250 Flow Meter, contact your Teledyne Isco representative or call the factory.

1.7 Controls, Indicators, and Connectors

The controls, indicators, and connectors of the 4250 Flow Meter are listed in Table 1-1, and their functions are briefly described. Refer to Figure 1-5 for a view of the connectors and their pin functions.

1.8 Technical Specifications

The technical specifications for the 4250 Flow Meter are found in Tables 1-2, 1-3, and 1-4. The anticipated longevity for a roll of paper used in the internal plotter is shown for various chart speeds in Table 1-5.

 **Note**

Various options and accessories used with the 4250 are described throughout the manual. For convenience, the part numbers for these items are listed on the Accessory Parts List found at the back of Appendix A Replacement Parts List. Part numbers for equipment not listed on this sheet are available from the factory

Pin Function

Pin	Function
A	Ground
B	12V
A	12V
B	Ground
C	Flow Pulse Output
D	Bottle Number Input
E	Event Mark Input
F	Inhibit/Enable Output
A	12V
B	Ground
C	SDO
D	Rain Gauge Input
A	12V
B	Ground
C	Sense Line
D	SDO
E	SDI
F	Analog Output Pulse
B	Tip
C	Ring
A	12V
B	Ground
C	Input Signal (+)
D	Temp (-)
E	Temp (+)
F	Switched 12V
G	Input Signal (-)
A	12V
B	Ground
C	Level (+)
D	Level (-)
E	Rcv (-)
F	Rcv (+)
G	Xmit (+)
H	Xmit (-)

Legend:
A = Channel 1 (-) Red
B = Channel 3 (+) Green
C = Channel 1 (+) White
D = Channel 2 (-) Brown
E = Channel 3 (-) Black
F = Channel 2 (+) Blue

Analog Outputs: 0-4-20 mA

Figure 1-5 4250 Side View Showing Connectors and Pin Functions

Table 1-1 4250 Controls, Indicators, and Connectors		
CONTROLS	SETTINGS	FUNCTION
ON/OFF	On - Off	Turns the flow meter on and off. Internal memory is protected with a standby battery. See Section 2 .
Keypad	Momentary Switches	24-key. 4 column matrix - Program flow meter through series of keystrokes prompted by messages on the display. Certain keys perform specific functions, (printing reports or entering program choices into memory). Arrow keys move through menus. Number keys enter numeric values. See Section 2 .
INDICATORS	READING	FUNCTION
Display	Multi-function	2-line, 40 characters per line, liquid crystal display (LCD.) Prompts you through program procedure; displays total flow, present flow rate and level. May also display parameter readings, if sensors present.
Internal Plotter	Various	Provides hard copy of total flow, level or flow rate variation over time; provides sampling information and a printout of the program. Prints reports. Generates up to 3 different linear data plots. Chart characters and plots are generated on plain paper roll with an ink ribbon.
CONNECTOR	TYPE	FUNCTION
12 VDC	2-pin male M/S	Connects 12 VDC power to flow meter
Sampler	6-pin male M/S	Connects flow meter to sampler. Provides 12V flow pulse to sampler (pulse width 78 ms). Receives sampler bottle number, composite sample, and event mark signal.
Rain Gauge/ YSI 600 Sonde	9-pin female M/S (Custom)	Connects flow meter to a Isco Rain Gauge or YSI 600 Multi-Parameter Sonde. Also provides output to High Low Alarm Relay Box.
Interrogator	6-pin female M/S	Provides serial data in/out and power. Can also be used with 4-20 mA Output Interface.
Modem (optional)	5-pin male M/S	Connects flow meter to telephone line for remote data transmission. This connector will only be present on units that have the optional modem installed.
Analog Output (optional)	6-pin male M/S	Provides analog data output from the flow meter to external, non-Isco control and recording devices.
Parameter	7-pin female M/S	Connects flow meter to parameter sensor: temperature, pH, or D. O. Note that you can only have temperature and one parameter (pH or D. O.) at the same time.
Area Velocity Sensor	9-pin custom special connector	Connects flow meter to area-velocity sensor. Also provides connection for internal vent tube from sensor.

Table 1-2 4250 Technical Specifications	
Physical and Electrical	
Size	16" high × 11 1/2" wide × 10 1/2" deep (40.6 × 29.2 × 26.7 cm) (without power source attached).
Weight	17 lb. 4 oz. (7.8 kg)
Material	High-impact molded polystyrene structural foam.
Type	Self-certified NEMA 4X Enclosure.

Table 1-2 4250 Technical Specifications

Display Type	2-line, 40 character/line alphanumeric dot matrix liquid crystal.
Power	12 to 14 VDC; 14 mA average at 12.5 VDC (printer set at 1" per hour, 1 minute level reading interval, 5 minute velocity reading interval.)
Typical Battery Life	(Standard 4 Ampere-hour nickel-cadmium battery.) 8 to 11 days with printer set at 1" per hour, 1 minute level reading interval, 5 minute velocity reading interval. 15 days with printer turned off .
Operating Temperature	0 to 140°F (-18 to 60°C).
Storage Temperature	-40 to 140°F (-40 to 60°C).
Additional Power Required for Optional Equipment	
Modem	60 mA maximum during operation; 0.1 mA maximum standby.
High-Low Alarm Relay Box	10 mA standby, typical; 190 mA - both relays operated.
Internal Printer	
Chart Speeds	Off, 1/2, 1, 2, or 4 inches per hour. See Table 1-5 for longevity in days.
Ribbon	19.7 ft. (6 m) black nylon - replaceable.
Operating Speed	1.5 lines per second at 68° F. (20° C).
Character Size	0.09" high × 0.07" wide (2.4mm × 1.7 mm), 12 pitch.
Printer Recording Span	User-selected from 1/4 ft. (3.6 cm) to over 30 ft. (9.1 m) with multiple over-ranges.
Chart Resolution	1/240 of selected recording span
Display Resolution	0.001 ft. (0.3 mm)
Paper	4.5" wide × 58 ft. (11.4 cm × 17.7 m) plain white paper, replaceable.
Printer Reliability	2.5 million lines MCBF (mean cycles before failure).
Reports Printed	Program selections, interval activity reports, flow meter history.
Printer Recording Modes	Level, flow rate, rainfall, temperature, velocity, pH (or) D. O.; includes totalized flow, sampler events,
Plotted Linear Data	3 different linear plots can be printed at the same time.
Flowlink Data Storage and Retrieval System	
Memory Partitions	Maximum of 6 user-defined memory partitions for level or event storage.
Data Storage	Rate of data storage user-selected in 1, 2, 5, 10, 15, 30, 60, or 120 minute intervals.
Baud Rates	Serial connection - 300, 1200, 2400, 4800, or 9600 baud. Serial connection with the optional internal modem - 2400 baud.
Storage	80,000 bytes, apportioned per reading as follows: flow = 4 bytes, level = 2 bytes, sample = 4 bytes, pH or D. O. = 1 byte)
Level Data	Level readings are stored as a 16-bit number representing .1mm (0.0394 inch); effective range is 0-65279 meters.

Table 1-3 Technical Specifications for the Standard AV Sensor

Weight Standard Range	2.1 lbs (.96 kg)
Extended Range	3.9 lbs (1.8 kg)
Sensor Dimensions	Length: 6.6 inches (6.8 cm) Width: 1.6 inches (4.1 cm) Height: 1.2 inches (3.0 cm)
Nose Angle	35° from horizontal
Cable Length Standard Range	25 ft (7.6 m)
Extended Range	50 ft (15.2 m)
Materials	Sensor: Polybutadiene-based polyurethane, stainless-steel Cable: Polyvinyl chloride (PVC) chlorinated polyvinyl chloride (CPVC)
Operating Temperature	32° to 160°F (0° to 71°C)
Level Measurement Method	Submerged pressure transducer mounted in the flow stream
Transducer Type	Differential linear integrated circuit pressure transducer
Level Measurement Range	
Standard Range	0.05 to 10.0 ft (0.015 to 3.05 m)
Extended Range	0.05 to 30.0 ft (0.015 to 9.14 m)
Maximum Allowable level	
Standard Range	20 ft (6.1 m)
Extended Range	40 ft (12.2 m)
Level Measurement Accuracy	
Standard Range	0.033 to 5.0 ft: ± 0.008 ft/ft (0.01 to 1.52 m: ± 0.008 m/m) >5.0 ft: ± 0.012 ft/ft (>1.52 m: ± 0.012 m/m)
Extended Range	0.05 to 15.0 ft: ± 0.03 ft (0.015 to 4.57 m: ± 0.009 m) 0.05 to 21.0 ft: ± 0.09 ft (0.015 to 6.40 m: ± 0.027 m) 0.05 to 30.0 ft: ± 0.30 ft (0.015 to 9.14 m: ± 0.090 m)
	@77°F (25°C). Includes non-linearity, repeatability, and hysteresis. Does not include temperature coefficient.
Compensated Temperature Range	32° to 100°F (0° to 38°C)
Temperature Coefficient	
Standard Range	0.05 to 4.0 ft: ± 0.005 ft/°F (0.015 to 1.22 m: ± 0.0027 m/°C) 4.0 to 10.0 ft: ± 0.007 ft/°F (1.22 to 3.05 m: ± 0.0038 m/°C)
Extended Range	0.05 to 30.0 ft: ± 0.008 ft/°F (0.015 to 9.14 m: ± 0.0044 m/°C)
	Maximum error over compensated temperature range, per degree of temperature change.
Velocity Measurement Method	Doppler Ultrasonic
Frequency	500 kHz
Typical minimum depth for velocity measurement	0.25 ft (75 mm)
Range	-5 to +20 ft/s (-1.5 to +6.1 m/s)

Table 1-4 Technical Specifications for the Low Profile AV Sensor

Weight	2.1 lbs (.95 kg) including cable and connector
Sensor Dimensions	Length: 6.00 inches (15.2 cm) Width: 1.31 inches (3.3 cm) Height: 0.75 inches (1.9 cm)
Nose Angle	110° from horizontal
Wetted Sensor Material	Epoxy, chlorinated polyvinyl chloride (CPVC), Stainless-steel
Cable Material	Polyvinyl chloride (PVC), chlorinated polyvinyl chloride (CPVC)
Cable Length	25 ft (7.6 m)
Maximum Distance (between sensor and module)	75 ft (22.8 m) with optional extension cables. The distance can be extended up to 1000 ft (300 m) with the optional Quick Disconnect Box.
Operating Temperature	32° to 122°F (0° to 50°C)
Storage Temperature	-40° to 160°F (-40° to 71°)
Level Measurement Range	0.033 to 10.0 ft (0.01 to 3.05 m)
Maximum Allowable level	20 ft (6.1 m)
Level Measurement Accuracy	0.033 to 5.0 ft: ± 0.008 ft/ft (0.01 to 1.52 m: ± 0.008 m/m) >5.0 ft: ± 0.012 ft/ft (>1.52 m: ±0.012 m/m) Accuracy per foot of change from calibrated depth @77°F (25°C). Includes non-linearity and hysteresis.
Temperature Coefficient	±0.0023 ft/°F (±0.0013 m/°C) Maximum error within operating temperature range at zero pressure (per degree of change from calibration temperature).
Maximum Long-term Drift	0.033 ft (±0.010 m)
Velocity Measurement Method	Doppler Ultrasonic
Frequency	500 kHz
Transmission Angle	20° from horizontal
Typical minimum depth for velocity measurement	1 inch (25 mm)
Range	-5 to +20 ft/s (-1.5 to +6.1 m/s)
Velocity Accuracy	-5 to +5 ft/s (-1.5 to +1.5 m/s): ± 0.1 ft/s (±0.03 m/s) 5 to 20 ft/s (1.5 to 6.1 m/s): 2% of reading Velocity accuracy for a uniform velocity profile in water with a speed-of-sound of 4,850 ft/s.

Table 1-5 4250 Chart Longevity

Table 1-5 4250 Chart Longevity	
<input checked="" type="checkbox"/> Note Report Generator is turned off.	
Chart Speed, Inch/Hour	Time to Empty Roll
4	7 ¹ / ₄ Days
2	14 ¹ / ₂ Days
1	29 Days
0.5	58 Days

Table 1-6 Battery Life Expectancy

Flow Meter Settings	Minimum	Default²	Maximum
Level Reading Interval	1 Minutes	5 Minutes	Continuous
Velocity Reading Interval	5 Minutes	30 Minutes	Continuous
Printer	Off	Off	4" per Hour
Report Generator	Off	Off	Every Hour
Average Current	14 mA	11 mA	70 mA
Nickel-Cadmium ³	10.7 Days ⁵	13.6 Days	2.1 Days
Lead-Acid ⁴	17.4 Days	22.1 Days	3.4 Days
<p>1. These values are approximations based on calculations; actual times for your flow meter may vary substantially due to factors of battery age, charge condition, operating temperatures, and component differences.</p> <p>“Minimum” settings are those providing the lowest average current draw. “Maximum” settings are those requiring the highest current draw. Your program should draw somewhere between the two. It is not possible to calculate the current draw for every possible program combination.</p> <p>2. The default settings are the program entered at the factory. You can reset the flow meter to the default program at any time by pressing the 1 and CLEAR ENTRY keys at the same time.</p> <p>3. The nickel-cadmium battery has a capacity of 4.0 ampere-hours at room temperature (20°C).</p> <p>4. The lead-acid battery has a capacity of 6.5 ampere-hours at room temperature (20°C). Both batteries are assumed to be fully-charged with at least 95% of rated capacity and in good condition. These calculations also assume a 5% safety factor at the end of discharge. Lead-acid batteries should never be completely discharged.</p> <p>5. All fractional times are rounded down.</p>			

1.9 How to Make Battery Calculations

To calculate battery life expectancy for an installation, you must know two things:

- The capacity of the battery you are using
- The average current draw of the flow meter or (other device) powered.

Battery capacity is expressed in ampere-hours. The battery manufacturer provides this information for each battery. This value is the product of a load current times an arbitrary time period: ten hours for nickel-cadmium batteries, and twenty hours for lead-acid types. The terminal voltage of the battery at the end of this time period is the discharged cell voltage, 10 volts for nickel-cadmium and 10.5 volts for lead-acid types. **Batteries are fully discharged well before the terminal voltage drops to zero volts.**

Isco batteries are rated at **4 ampere-hours** for the nickel-cadmium and **6.5 ampere-hours** for lead-acid types. Convert the battery current capacity into milliamperes and then divide this figure by the average current drawn by the unit. This will give you a number in hours. Divide that figure by 24, and you will have the number of days.

The published ampere-hour figures do not mean that you can expect to draw 4 amperes from the nickel-cadmium battery (or 6.5 amperes from the lead-acid battery) for one hour. At the one-hour rate, discharges are typically less than half the ten- or twenty-hour rate.

To convert ampere-hours to milliamperes, multiply by 1,000.
Examples:

$$4 \text{ ampere-hours} \times 1,000 = 4,000 \text{ mAh}$$

$$6.5 \text{ ampere-hours} \times 1,000 = 6,500 \text{ mAh}$$

If you divide this figure by the average current of the flow meter, say 15 mA, you will have:

$$4,000 \div 15 = 266.67 \text{ hours}$$

Divide this number by twenty-four to get days:

$$266.67 \text{ hours} \div 24 = 11.1 \text{ days}$$

For considerations of safety, we suggest you subtract 10% from this number (100% – 5% for 95% capacity and 5% for a reserve at the end of discharge).

$$11.1 - 1.1 = 10 \text{ days}$$

This is the battery expectancy for a nickel-cadmium battery with a 15 mA continuous average drain, with a 10% derating factor. You can use the same method to calculate for lead-acid batteries, except the current will be 6,500 mA, and the period correspondingly longer, in this case a little over 16 days. You can run the full number of days calculated without derating if your batteries are new and at 100% capacity, but you will leave yourself no safety factor if you are in error on either of these assumptions. Remember, if the battery fails, there will be a period of time during which no measurements will be taken, (and no data stored, if you are also using FLOWLINK® software).

Batteries lose capacity as they age. Capacity also drops off as temperature falls. Low temperatures make less capacity available due to the slowing of the chemical reactions, while high temperatures accelerate the deterioration of battery plate separators, particularly if they are aged. Nickel-cadmium batteries show fairly rapid rates of self-discharge. A battery that is fully charged and then placed in storage will lose some capacity each day. In a week, this could easily be 5% or more.

When using lead-acid batteries, you must be careful to avoid complete discharge, as this may cause cell reversal, which will ruin the battery. Also, complete discharge in low temperature ambients may cause the battery to freeze, which can deform the plates or even crack the case. **Always operate these batteries with a reserve factor.**

1.9.1 Calculating Current Draw

Calculating current draw for a 4250 Flow Meter is somewhat more difficult than calculating the battery capacity. You cannot simply measure the idle current of the unit unless the printer and report generator are turned off in the program. These functions require power periodically, but not all the time. If the figures given in the previous table are not satisfactory for your application, you can use the following procedure (shown in Figure 1-6) to measure the actual current draw.

 Note
--

Do not attempt this procedure unless you have the proper equipment available and know how to make electrical measurements.

To measure current for a varying load requires a more-sophisticated type of multimeter, one that is capable of averaging high and low readings over a period of time. The *Fluke® 87 Multimeter* is one example of this type of meter. You should set the meter on MIN/MAX and let it run with your program for several hours or more. Other manufacturers' meters are also acceptable, but only if they are capable of averaging current draw. For a more representative test, the area-velocity sensor should be attached and submerged in water. You should run the test for at least eight hours, longer if necessary, or until the flow meter has exercised the entire program. The longer you run the test, the more accurate the average will be.

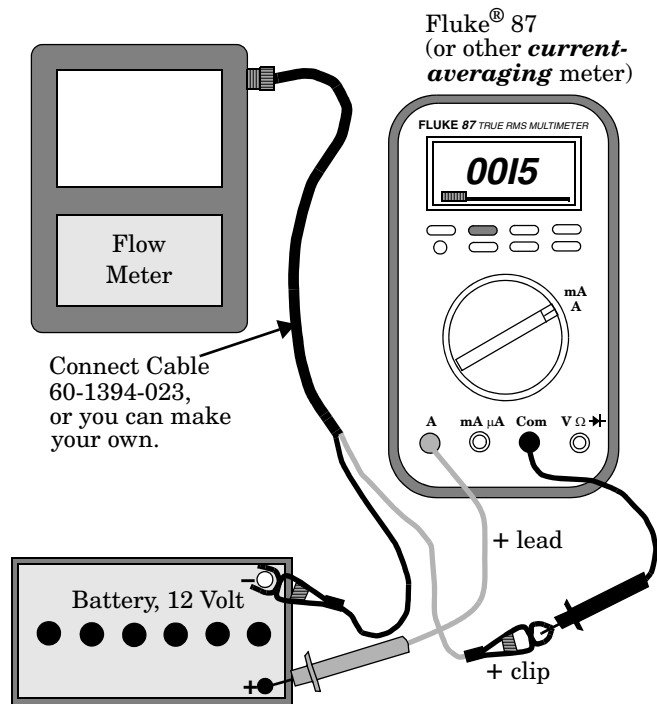

A good quality, adjustable, regulated DC power supply can be substituted for the 12-volt battery. The power supply should have at least 3 Amperes output, preferably more, and capable of overcurrent surges.

Figure 1-6 Measuring Flow Meter Current

More information about batteries used to power Isco equipment is available from the *Isco Power Products Guide*, which is shipped with this manual and any flow meter order.

4250 Flow Meter

Section 2 Programming

2.1 Getting Started

You must program the 4250 Flow Meter to accurately monitor a flow stream. You must also install the area-velocity sensor. The 4250 will usually also need a primary measuring device, a structure placed across a stream that regulates flow. This section describes programming the flow meter with the aid of the keypad and display. There are nine program steps that control all aspects of the flow meter's operation.

Teledyne Isco ships the flow meter with a program already installed that is called the **default program**. You can use this program as an example to see the flow meter's capabilities. Note that the default program is just for testing the unit at the factory. The flow meter's internal computer must always have something programmed into the unit, so that becomes the default program. Your flow situation will usually require other programming choices. The text provided with each screen explains the reasons for the various menu options.

2.1.1 Operation of the Display

The display is a two-line, forty character-per-line liquid crystal (LCD). It has a backlight feature for easy viewing in low light situations. The display has three different operating modes: **normal**, **programming**, and **messages**. In the **normal mode**, the display shows such things as level, flow rate, total flow, parameter measurement, etc. In the **programming mode**, the top line of the display shows each step as you work through the program while the bottom line shows the choices available for that step. In the **message mode**, the display provides instructional information, such as how to leave programming, or what to do if you have entered a number that is out-of-range.

Following is a "normal" display on the flow meter. This is typical of what the flow meter will display when it is in the normal operating mode and you are not programming it.

0000004.78 CF	1.13 FT	16-NOV-02
1.03 CFS	(X X)	8:25:37

An interpretation of the numbers on this display would be as follows: Time and date will be replaced by pH/D.O. and temperature if you are using parameter sensing. The (X X) to the right of the time indicates letters that may appear from time to time on the 4250 Flow Meter.

The letter **C** will appear when the flow meter is communicating with a remote computer (Flowlink applications only). The letters **E** or **D** will appear (Enable or Disable) when the sampler enable function (step 6) is programmed by condition. (Programmed by

condition means that the flow meter will enable the sampler only when a certain condition or set of conditions, sensed by the flow meter, are met.)

<i>Total Flow</i>	<i>Current Level</i>	<i>Date (or pH/D.O.)</i>
<i>Flow Rate</i>		<i>Time (temperature)</i>

Following is a typical programming display on the flow meter. One of the items in the second line will be flashing. The item flashing is the selection currently held in memory.

TOTALIZED VOLUME UNITS • CF •• GAL •• M3 •• AF •• L •• MGAL •
--

Following is a typical display providing instructional information:

CHANGES HAVE BEEN MADE IN STEP PRESS '0' TO CONTINUE, PRESS '1' TO DISCARD

If you stop programming for more than two minutes, the flow meter will time out, and whatever is on the display (message or program step) will revert to the “normal” display, shown previously.

The program consists of steps and substeps. The steps are listed on the flow meter front panel. Most steps contain several substeps. Generally, you need to complete all the substeps before stopping, or the flow meter will reject the changes you made for that step after it times out. There are some exceptions.

The flow meter keeps in memory any changes that you made for the finished steps (all substeps completed before stopping). Most steps not finished when you stop will return to the previous selection.

2.1.2 Keypad Functions

Programming is done on the flow meter’s keypad with prompts from the display. The following sections describe the function of each key.

OFF and **ON** - These two keys turn the flow meter off and on.

Go To Program Step - Pressing this key lets you go directly to a particular program step without passing through all the steps of the entire program. The display will ask you to enter the number of the step you want to program. Enter the number by pressing one of the number keys. There are nine program steps, so numbers from one to nine are valid.

Exit Program - Press this key when you want to leave the programming mode and return to the normal operating mode.

Clear Entry - This key lets you return to the previous entry for a program step if you have changed the entry, but not yet pressed Enter.

Enter/Program Step - This key has two functions. One is to enter a program selection into the flow meter’s memory (Enter). The other is to step through the program (Program Step).

Print Program - Pressing this key will make the flow meter print out a complete list of the current program choices retained in memory.

Print Report - One function of the flow meter is to print reports of all recorded activity at regular intervals. The contents of these reports are defined in step 1. If you set up the report generator, you can have a report printed anytime by pressing this key. The report will cover the time from the last scheduled report up to when you press this key.

The flow meter will print its next report at the next scheduled time. Note that if power fails for five minutes or more, the flow meter will print a report when power is restored that will cover the interval between the last report and the time that the power failed. The next report will cover the time from the power failure to next scheduled report time.

Chart Advance - Pressing this key causes the paper chart to advance through the printer at the fastest possible speed. Nothing will be printed while you are holding this key.

Chart Reroll - It is possible to unroll the chart from the take-up roll on the flow meter by pulling it out with your hands. Pressing this key lets you rewind the chart onto the take-up roll.

Number keys - These keys let you enter numeric values into the flow meter when programming.

Decimal Point - This key lets you enter a decimal point into a numeric value when programming. On flow meters equipped with the optional modem only, you can use this character as a comma (delay) when entering dialout numbers.

Arrow keys - These keys, referred to as the **left** and **right arrow keys** let you select a programming option by moving across the menus shown on the second line of the display.

+/- key - This key lets you enter a plus or minus to a quantity entered. Its most common use is in entering values for the **equation**, a method of flow conversion. On flow meters equipped with the optional modem only, you can use this character as a dash when entering dialout numbers.

2.2 Programming Procedure

To start programming, turn on the flow meter and wait for the display to settle. Then either press the **Enter/Program Step** key (generally referred to as **Enter**) or the **Go To Program Step** key.

The display will change to two lines of text; the first line describes the step you are programming and the second line shows the choices available. One choice shown will be flashing. The flashing indicates that this is the current one held in the memory. If you are satisfied with this choice, just press **Enter**, and the flow meter will advance to the next step.

If you want a different choice from the one that is flashing, you can move across the display by using the **left** and **right arrow** keys. Each time you press the **right arrow** key, the flashing selection will move one position to the right. This will continue until the flashing cursor is over the last display.

You may notice an arrow pointing to the edge of the display. This indicates additional choices are available beyond what you can see. By continuing to press the **right arrow** key you can view these unseen menu options. After reaching the furthest option, the arrow will move to the left side of the display, indicating that there are options unseen to the left. These will be the options you started with. If you want to go back to one of them, use the **left arrow** key until the option you need reappears. When the desired selection is flashing, just press **Enter**. The display will then automatically advance to the next step of the program.

All of the program steps contain “substeps” that must be completed before you advance to the next step. Some steps, like **Reset Totalizer** contain only a few substeps. Some steps require the entry of a **numeric value**. Program these steps by using the number and decimal keys to enter the value.

Note that it is possible to program the flow meter in the shop, rather than at the job site, with the exception of step 3, Adjust Level/Parameters. To set level you must make an accurate measurement of the level in the flow stream and then enter that value. This can only be done at the job site.

If you are programming the flow meter for the first time, generally you will press **Enter**, start with step 1, and go on from there. If the flow meter has been in use and you need to change only certain aspects of the program, you would more likely use the **Go To Program Step** key. With this key you can go directly to the program step you need to change, which saves time.

If you change an entry and do not like it you can make the display revert to the original entry by pressing **Clear Entry**. If you have already pressed **Enter**, however, the new value will be in memory. To change it, press **Exit Program**. If you are in the middle of a program step with multiple substeps, the flow meter will display, “Changes have been made in step; press **0** to continue or **1** to discard.” If you press **1**, the display will return to normal and the last step you were working on will revert to its previous selection. (Any program step you completely change before exiting will remain changed.)

You can re-enter the program with either **Enter** or the **Go To Program Step** keys. If you become confused while programming, the best suggestion is to press **Exit Program** and start over. Also remember that you can have the flow meter print a complete list of your program choices by exiting the program and by pressing the **Print Program** key as soon as the display returns to the normal operating condition, displaying level and total flow, etc.

2.3 Description of Program Steps

The Program Steps for the 4250 are:

1. Operating Mode
2. Flow Conversion
3. Adjust Level/Parameters
4. Reset Totalizer
5. Sampler Pacing
6. Sampler Enable
7. Alarm Dialout
8. Printer
9. Reports/History

Note

2.3.1 Step 1, Operating Mode

If you choose NOT MEASURED for any selection, the flow meter will make no further reference to that value or function for the rest of the program, and you will not be able to activate that process or function later on unless you reprogram **step 1**. If there is a feature or option you need that does not appear on your display when the manual says it should, return to **step 1** and make sure you have not inadvertently left it turned off in either the Program or Setup menus.

Note that selecting some features automatically excludes others. For example, selection of pH or D. O. excludes the other parameter, unless you use the **YSI 600 Multi-Parameter Sonde**, which measures pH, D.O., and conductivity at the same time.

Step 1, Operating Mode, determines how you set up the flow meter. In this step there are two choices, **Program** and **Setup**. **Program** advances you to **step 2**, and from there on you correlate the flow meter to the flow stream. **Setup** selects various basic “housekeeping” features for the flow meter. Here you determine the internal clock, site identification, measurement setup, hysteresis, report contents, operation of the display backlight, and program lock. In **Program** you select the units of measure the flow meter will use for the display, calculations, and reports.

This method keeps program size manageable and makes programming more efficient. By turning off unneeded features of the program early, you do not have to keep de-selecting those features over and over as you work through the program.

Consequently, you should choose carefully from the first step. We suggest you study the program first, then fill out the *Programming Worksheets* (in the back of this manual), and program the flow meter last, if you are unfamiliar with the unit.

2.3.2 Step 2, Flow Conversion Type

Step 2, Flow Conversion Type, determines how the flow meter calculates flow rate and total flow. In general flow is calculated for the 4250 from measured level, the size and shape of the

channel, and the velocity of the flow stream. Occasionally, the 4250 may be used with a **primary measuring device**. In such cases, the area-velocity sensor will function as a level-only measuring device, with velocity as a secondary indicator.

A primary measuring device is a structure placed across a flow stream through which the entire stream must flow. These devices are made in a number of styles and sizes, but they all have one thing in common: For any type of primary measuring device there is a known relationship between the level in the flow stream ahead of the device and flow rate through the device. Consequently, after you measure level with the flow meter, it can calculate flow rate and total flow from the measured level, by consulting built-in look-up tables.

Detailed information about many commonly-used primary measuring devices is provided in the *Isco Open Channel Flow Measurement Handbook*. This book provides formulas, flow rates at various levels, and values for maximum head, as well as much interesting descriptive material, and is available from Teledyne Isco. If your installation uses a nonstandard primary device, you should consult the manufacturer of the device for flow rates at given levels. The flow meter will then calculate a flow conversion for such a device on the basis of the manufacturers' data you enter as **data points** or an **equation**. In some instances, a nonstandard primary device could be supplied with a flow equation; you can enter that equation into the flow meter and the flow meter will calculate the flow rate from that equation.

Area-velocity flow conversion – is the customary flow conversion used with the 4250. The area-velocity sensor measures both the level of the flow stream and the velocity at which the liquid is moving. It uses ultrasonic reflection to measure the velocity and a pressure transducer to measure the level. you provide the third dimension of the flow cross-section by entering the width or diameter of the pipe or channel. The 4250 uses this combination of measured level, velocity, and the dimension of the channel to calculate flow. This method is unique because it is the only flow conversion that can measure all of these different types of flow: submerged, full pipe, surcharged, and reverse.

Standard (non-area-velocity) Flow Conversion – The 4250 normally calculates flow based on the velocity of the flow stream, the cross-sectional shape of the channel, and the measured level. However, you can also configure the 4250 for level-to-flow conversion rather than area-velocity. The conversion types are: **Weir/Flume, Manning, Data Points, and Equation**.

You use **Weir/Flume** flow conversion when your primary measuring device is a weir or a flume. A weir is a wall or dam across the flow stream. Water must rise to the point where it flows over the top of the wall. The measured level upstream behind the wall is used to calculate the flow rate. Flumes differ from weirs in that there is no wall or barrier, but instead a restriction, typically a sharp narrowing or change in the slope of the channel that restricts the flow. Again, the measured level of the stream at some point ahead of the restriction is used by the flow meter to

calculate flow. In this flow conversion mode, the flow meter uses internal look-up tables for many common primary measuring devices.

An **Equation** is used when you have a non-standard primary device, or want to use different values from those programmed into the look-up tables of the flow meter. Equation uses the standard flow equation:

$$Q = k1H^{P1} + k2H^{P2}$$

Where **Q** equals flow rate; **k1** and **k2** are constants; **H** is level (or head), and **P1** and **P2** are the powers to which the two **H** terms are raised. (Your equation may not have the second term, in which case you would enter **0** for the second constant, **k2**.) Most common primary devices are supported in the flow meter's software, so generally you will not need this option. But it is available for those needing to enter their own values, or for those who have a nonstandard primary device for which an equation can correlate level and flow.

MANNING Flow Conversion uses the Manning formula to calculate flow in open or closed (non pressurized) gravity-flow situations based on slope, diameter, and roughness of the pipe. The Manning formula is named for its developer, Robert Manning, a 19th-century Irish civil engineer. There is no primary measuring device as such. Instead the pipe, with considerations for its slope and internal roughness, serves as the primary device. The 4250 Flow Meter can calculate flow in round pipes, rectangular, U-shaped, or trapezoidal channels based on this formula.

Data Point Flow Conversion (DATA POINTS) calculates flow based on a set of user-entered data points for a flow stream. Data consist of correlated level and flow measurements for the stream. Like the Equation method of flow conversion, this flow conversion is most commonly used where the primary measuring device is nonstandard, but where tables of level and flow rate data are available from the device manufacturer. The 4250 Flow Meter has space for four sets of data with as many as fifty points per set. The flow meter then calculates flow from these data tables using a three-point interpolation.

2.3.3 Step 3 - Adjust Level, Parameters

Adjust Level, Parameters calibrates the measuring sensors that provide the flow meter with level and other information. In this step you set the level that the flow meter measures. First you measure, as accurately as possible, the level in the flow stream. Then you enter this value with the numeric keys.

 **Note**

Accuracy is important. The level measurement and channel dimensions that **you** enter into the flow meter provide the basis for **all** subsequent flow calculations.

The flow meter also has an input port for measurements other than level. This is the **Parameter Port**. Here you can measure such variables in the flow stream as temperature, pH (the acidity

or alkalinity of a solution) and D.O. (dissolved oxygen) in the flow stream. You can have either pH with temperature, D.O. with temperature, or temperature alone. The port is not dedicated to a particular sensor, except through programming. You can change the sensor. For example, you can change from a pH probe to a D.O. sensor if you change the programming. Selection of one parameter will keep the other from showing up on the menus. Note, however, that it is possible to measure several different stream conditions including pH and D.O. at the same time with the YSI 600 Sonde.

The YSI 600 Sonde

The YSI 600 Sonde is a multi-purpose water quality measurement device. It is intended for use in research, assessment, and regulatory compliance. The sonde attaches to the modified RAIN GAUGE connector on the 4250. Flow meters having only a 4-pin rain gauge connector will not support the YSI Sonde. If you wish to upgrade your flow meter to use this system, contact the factory. Note that you can have both the YSI 600 Sonde and the Rain Gauge connected to the flow meter at the same time by using a special Y-connect cable.

The YSI 600 Sonde can measure the following water qualities: **dissolved oxygen (D.O.), conductivity, temperature, and pH.** Conductivity measurements made by the sonde can be used to calculate specific conductivity, salinity, and total dissolved solids. A brief description and specifications for the YSI 600 are printed in Section 4. You may also contact the factory or your Teledyne Isco representative. More information on the sonde is found in the YSI 600 Manual, shipped with each YSI 600 Sonde.

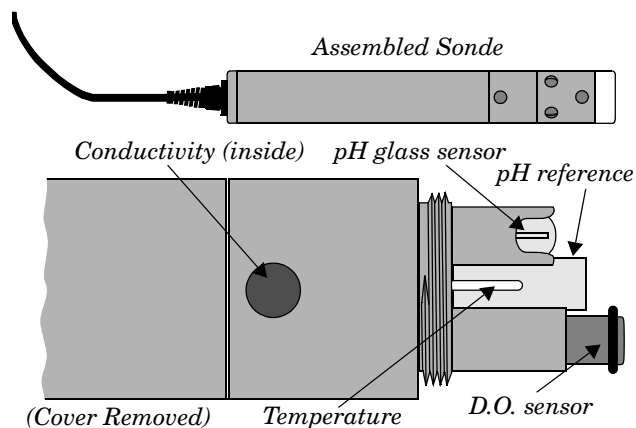

Figure 2-1 The YSI 600 Sonde

2.3.4 Step 4 - Reset Totalizer

In this step, you decide whether to reset the flow meter's internal flow totalizers. If the installation is permanent, you generally won't reset the totalizer. If you are using the flow meter as a portable recording unit and move it from site to site, you would generally reset the totalizer between sites.

2.3.5 Step 5 - Sampler Pacing

It is common to use a flow meter with an Isco Automatic Wastewater Sampler. Typically, the flow meter signals the sampler to take a sample after a certain volume has passed. It might also occur after a certain condition or set of conditions has either changed or been met. This step allows you to determine that control. There are several possible options—**DISABLE**, **CONDITIONAL**, **VOLUME**, and **FLOWLINK**. **DISABLE** will keep the sampler from receiving a flow pulse from the flow meter. **VOLUME** allows the flow meter to signal the sampler whenever a specific flow volume has passed by. **Flowlink** (this option will only appear if you are using Flowlink software) allows the sampler to be signalled from the flow meter as a result of conditions determined by Flowlink.

Flowlink is Teledyne Isco's proprietary data acquisition and management software. Flowlink works with personal computers, modems, and laptop computers to monitor flow meters from a distance. Consult the factory for more details about Flowlink.

VOLUME makes the flow meter pace the sampler after a specific volume passes through the stream.

CONDITIONAL allows pacing of the sampler by the flow meter when a particular condition has been met, or has changed. Among these conditions are changes in level, flow rate, temperature, rainfall, (if you are using the optional rain gauge sensor), D.O. (dissolved oxygen), or pH. You can also use a pair of conditions, or if you are using the YSI 600 sonde, you can select multiple conditions from its sensors.

Note

If you choose **CONDITIONAL** for sampler pacing and it doesn't seem to work properly for you, read the section on hysteresis. Then check the hysteresis setpoints for your conditions. (The defaults are all zero.)

You must have the appropriate sensors attached to the flow meter to measure temperature, D.O., pH, conductivity, etc.; the flow meter cannot do this by itself, nor does it occur automatically.

2.3.6 Step 6 - Sampler Enable

Sampler Enable means that in a combination flow meter/sampler pair, the flow meter controls the sampler's ability to run its own program. The difference between **step 5**, sampler pacing, and **step 6**, sampler enable, is that in sampler pacing, the flow meter merely sends flow pulses to the sampler from time to time. The sampler counts these flow pulses to determine when to take a sample (according to its own programming).

With sampler pacing, the sampler is always enabled. With sampler enabling, the flow meter can actually stop operation of the sampler. The sampler is still set up to run its own program, but the inhibit/enable line from the flow meter will determine when and whether the sampler runs its program. This feature is useful for storm water runoff monitoring applications, where it may be necessary for the flow meter/sampler pair to have to wait a long time between storm intervals.

Again, changing or meeting a condition or set of conditions triggers the enabling. The conditions that can be used for sampler enabling are similar to those used for sampler pacing: level, flow rate, rainfall, temperature, dissolved oxygen, pH, or a combination of these conditions. The YSI 600 Sonde provides several measurements at the same time. You must have the appropriate sensors for rainfall, temperature, D. O., pH and the YSI outputs.

2.3.7 Step 7 - Alarm Dialout Mode

Note

You must have the optional modem to make use of this program step. The menus will not even appear unless the flow meter has a modem installed.

This feature allows you to program a 4200 Series Flow Meter to signal a remote location through a telephone line. The Alarm Dialout is useful if you need to signal a remote location when there is a change of condition in the flow stream that could constitute an alarm. You can program as many as five different eighteen-digit telephone numbers into the flow meter in decreasing order of importance. The modem is capable of speech.

DISABLE inhibits this function altogether. **CONDITIONAL** lets you program the flow meter to signal these alarms for a variety of reasons. You can use rainfall, time, level, flow rate, dissolved oxygen, pH, rate-of-change, a combination of conditions, or define the operation through Flowlink software from another computer. **STORM** lets you set the alarm through a combination of rainfall and time. You can also program the interval between calls and set up the system to reset the alarm condition by dialing back from the remote telephone.

2.3.8 Step 8 - Printer

All 4250 Flow Meters have a built-in printer. The printer is more than just a printer, as it is capable of plotting linear data along with printing alphanumeric (letters and numbers) messages. In this step you set the speed for the chart to advance, from $\frac{1}{2}$ " to 4" per hour. Chart speed is set according to the amount of resolution you want to see on the chart. If there is much activity on the chart, you would generally choose a faster speed so the marks are more "spread out" and are easier to interpret. If there is little activity on the chart and you want the flow meter to run for long periods without having to change the chart paper roll, you would probably pick a slower speed.

The flow meter is capable of plotting three separate data lines on the chart in addition to the alphanumeric messages. These lines may indicate various things, such as level, flow rate, pH, dissolved oxygen, or temperature. Note that you must have the appropriate sensors for pH, DO, and temperature to make use of these plots. Rainfall is printed as a bar-graph. The printer is capable of plotting over-ranges for the data lines it plots. You can

tell when the printer is in over-range if a data line goes off the chart on the right side and then immediately starts over again plotting on the left side.

2.3.9 Step 9 - Reports/History

This step lets you program the flow meter to print out regular reports on the internal printer. The reports the flow meter prints are a summary of activity the unit records over a period of time. Typically included are such items as maximum and minimum flow rates, the time they were reached, sample records, etc. The flow meter lets you create two separate reports, and lets you define what appears on them to a great extent. Note that the contents of the reports are defined in Setup in **step 1**. **Step 9** merely lets you turn them off and on and set the timing. You can define the start time, the interval between reports and other aspects of the report.

History provides a record of changes made to the flow meter's program or operation events. As many as 50 changes can be stored in the flow meter's memory at a time. The memory can store up to 50 history items and 200 sample events at a time.

2.4 Interpreting the Program Screens

Following are the program screens as they appear on the display of a 4250 Flow Meter. Explanations of most of the screens will be provided.

Note

Some items that appear in the menus have parentheses (...) around them. This means that the item *may* or *may not* appear on your flow meter. Choices made from the beginning of the program will make some options unavailable later.

An example of this is the pH/D.O. option. Selection of one in **Step 1** will keep the other from appearing in all following menus.

This list does not include all possible screens for the unit, but does cover the screens found in a typical programming sequence. Some diagnostic and error screens are covered in Section 5.

2.4.1 Operating Mode

Turn on the machine. Wait for the display to settle. Then press the **Enter/Program Step** (Enter) key. The following will appear. (Step 1) If the following menu does not appear, press **Exit Program**, then **Go To Program Step**, then press **1**.

```
SELECT OPTION
• PROGRAM •• SETUP •
```

PROGRAM is always the default. If you press **Enter**, the display will automatically advance to the next display, which will ask you to select units of measurement. If you select SETUP, the following will appear:

```
SETUP OPTIONS: 'EXIT' TO QUIT
• SET CLOCK •• SITE ID •• MEASUREMENT SETUP •
```

If you press the **right arrow** key, the following options will appear in this order on the display:

SETUP OPTIONS: 'EXIT' TO QUIT
• STATUS ENABLE/ALARM HYSTERESIS •

SETUP OPTIONS: 'EXIT' TO QUIT
• OPTIONAL OUTPUTS •• REPORT SETUP •

SETUP OPTIONS: 'EXIT' TO QUIT
• LCD BACKLIGHT •• (LANGUAGE) •• PROGRAM LOCK •

SETUP OPTIONS: 'EXIT' TO QUIT
• (LANGUAGE) •• PROGRAM LOCK •• PROGRAM •

US domestic models contain only English, plus one other foreign language, as ordered.

If you select SET CLOCK, the following will appear:

YEAR MONTH DAY HOUR MIN
XXXX XX XX XX XX

Enter the year (four digits), the month (01-12), the day (01-31), the hour (01-24), and the minute (01-59).

If you select SITE ID, the following will appear:

SITE ID: XXX

You can select any suitable three-digit number for the site identification.

If you select MEASUREMENT SETUP, the following will appear. You will have to use the **right arrow** key to bring all the options on screen:

MEASUREMENT SETUP
• LEVEL READING INTERVAL • (VELOCITY READING)•

MEASUREMENT SETUP
• (MINIMUM DEPTH)••(ZERO LEVEL OFFSET)•

MEASUREMENT SETUP
• (ZERO FLOW ON ERROR)••DO/PH READING INTER-

MEASUREMENT SETUP
• DO/PH READING INTERVAL••YSI 600 READING INT-

LEVEL READING INTERVAL refers to how often the flow meter takes a level reading. LEVEL refers to the level in the flow stream.

DO/PH READING INTERVAL refers to the measurement of specific aspects of the flow stream other than amount. 4250 Flow Meters support measurement of three different characteristics: **temperature**, **pH** (the relative acidity or alkalinity of a solution), and **D.O.**, dissolved oxygen.

 **Note**

If you are using the Isco D.O. sensor or are sensing D.O. with the YSI 600 Sonde, select as long a measurement interval as is practical for your application. The reasoning is that the D.O. sensor is turned off between measurement intervals and this turned-off period prolongs the life of the sensor.

YSI 600 READING INTERVAL refers to the YSI 600 Sonde. The flow meter can measure several different aspects of the stream at the same time, including pH, D.O., temperature, plus conductivity.

If you select LEVEL READING INTERVAL, the following will appear:

LEVEL READING INTERVAL
•CONTINUOUS•15 SEC•30 SEC•1 MIN•2 MIN•5 MIN•

The LEVEL READING INTERVAL option is a way to conserve power in battery-powered installations. If your installation is AC-powered, you can simply select CONTINUOUS. **Considerable power is expended in generating the ultrasonic pulses in the level sensor.**

Select the longest acceptable interval between readings if operating on battery power. If you need a faster response time, select one of the shorter intervals. If operating on battery power, you may have to seek a compromise between short reading intervals and battery life expectancy.

If you select VELOCITY READING INTERVAL, the following will appear:

VELOCITY READING INTERVAL
•CONTINUOUS•2 MIN•5 MIN•15 MIN•30 MIN•

Returning to the MEASUREMENTS menu, if you select MINIMUM DEPTH, the following will appear:

MINIMUM DEPTH FOR VELOCITY MEASUREMENT
•2 IN/50 MM•3 IN/75 MM•4 IN/100MM•

Standard and Extended Range Sensors – Three selections are available for the minimum depth for velocity measurements: 2, 3, or 4 inches (50, 75, or 100 mm). The Minimum Depth is the minimum amount of water above the bottom of the sensor that is required to obtain a velocity reading. This depth varies with the velocity of the flow stream; at higher velocities, the depth is greater.

When the level of the flow stream falls below the Minimum Depth, the flow meter approximates the velocity readings using velocity readings taken earlier, when depths were greater than the minimum. Under these conditions, the flow meter will not be able to detect the direction of the flow in the channel.

Determine the correct selection for the Minimum Depth by testing the flow meter for a period of time with the default selection: 3 inches. In most installations this will be the optimum selection. If, after examining the velocity data, you see a sharp decrease in velocity as the level readings approach 3 inches, increase the minimum depth to 4 inches. You can use the 2-inch option when the channel produces flows of very low velocity.

Low Profile A-V Sensors – These sensors do not have a program selection for minimum depths. Low profile sensors attempt to measure velocity regardless of depth. Typically a low profile sensor provides error-free velocity readings to depths as low as 1 inch (25 mm).

Note

The MINIMUM DEPTH setting will only appear if you are using a **standard** 10 ft or 30 ft AV probe. This setting will not appear if you are using a low profile AV probe. The standard probe cannot sense velocities below two inches of depth. Measurements below the minimum depth are approximations based on the velocity characteristics of the stream and previous measurements at other levels.

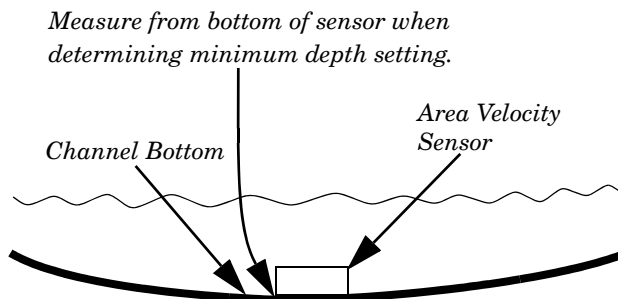

Figure 2-2 Measuring Minimum Depth

If you select ZERO LEVEL OFFSET, the following will appear:

ZERO LEVEL OFFSET
OFFSET = 0.00FT

This option lets you mount the probe somewhere other than at the bottom of the channel. This is useful when there is a problem with silt or sludge in the center of the channel.

Enter a value for the **vertical distance** the probe is installed above the true zero level of the flow stream. For example, if the probe is mounted on the side of the pipe at a point one foot higher than the true zero level (at the bottom of the pipe), the zero level offset is one foot. See Figure 2-3.

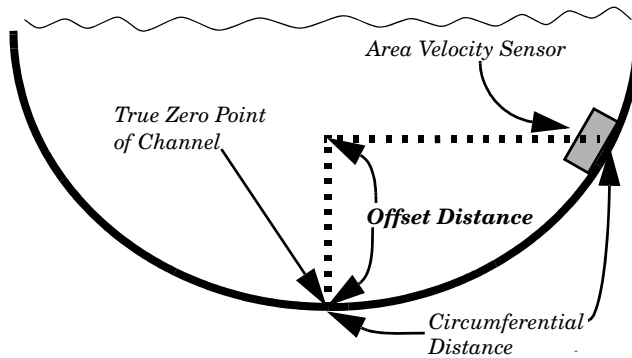

Figure 2-3 Measuring Offset Distance

Note

Do not confuse the *circumferential* distance between true zero and the location of the probe with the *vertical* difference (height). If you install the probe at the true zero level of the pipe or channel, you would enter **0** for the offset. Refer also to the installation section for the area-velocity sensor.

If you select ZERO FLOW ON ERROR, the following will appear:

ZERO FLOW ON ERROR
•YES••NO•

When the 4250 flow meter cannot obtain a valid flow measurement, it will report an error. This option tells the 4250 how to respond to an error measurement. The object is to select the option that gives you the greatest overall accuracy.

Selection of YES will make the 4250 register zero flow until the next valid measurement can be made. Selection of NO will make the flow meter continue to use and display the last valid measurement prior to the ERROR reading. An error measurement does not necessarily mean that there was actually no flow. It simply means that the flow meter was unable to obtain a valid measurement. This can occur when the velocity drops too low to measure or the probe is buried in sludge. ZERO FLOW ON ERROR will report errors if the level is below minimum depth.

Selection of YES or NO depends on your situation. If you are running a sampler with the flow meter and velocity is at times so low as to be almost non-existent, you would probably select YES (set flow to zero) to prevent the flow meter from tallying unrealistic flow totals to prevent the sampler from taking unrepresentative

tative samples. However, if your stream shows continuous flow and the sensor detects an error, you would probably select NO (use previous reading).

If you select DO/PH READING INTERVAL, the following will appear:

```
DO/PH READING INTERVAL
•CONTINUOUS•15 SEC•30 SEC•1 MIN•2 MIN•5 MIN•
```

Again, this selection is offered as a means of saving battery power. After selecting the appropriate parameter reading interval, press **Enter**. The **Setup** menu will reappear. This time, select YSI 600 READING INTERVAL from the menu. The following display will appear:

```
YSI 600 READING INTERVAL
•CONTINUOUS•15 SEC•30 SEC•1 MIN•2 MIN•5 MIN•
```

After selecting the appropriate parameter reading interval, press **Enter**. The **Setup** menu will reappear. This time, select STATUS from the **Setup** menu. Press **Enter**. The following will appear:

```
MODEL 4250 HW REV: XXXXXX SW REV X.XX
ID XXXXXXXXXXXXX
```

HW REV refers to the hardware revision number.

SW REV refers to the software revision number.

ID is an identification number for the flow meter.

If you press **Enter** again, you will see the following display:

```
SIGNAL STRENGTH X%
SPECTRUM STRENGTH X%
```

This value indicates the functioning of the area-velocity sensor. (The flow meter goes into the continuous reading mode whenever this screen is displayed.) This display exists primarily as a diagnostic tool for telephone troubleshooting. There is no “magic” number you should expect to see. If the flow meter is displaying valid level/flow readings, you do not need to worry much about the numbers. The numbers become important when you **cannot** get valid level/flow readings. You can apply the following explanations to the values displayed.

Signal Strength	Spectrum Strength	Explanation
0%	0%	<i>Unit is approximating velocity. (Appears when level is below minimum velocity depth.)</i>
0%	ERR	<i>Not enough reflective particles.</i>
ERR	ERR	<i>Not working—call factory.</i>

If there is a number greater than zero displayed for **signal strength**, the following is generally indicated:

1 = a very weak return signal; 100 = a very strong return signal. Numbers from 10 to 90 are normal, and numbers of 50 to 90 are typical for sewers.

If there is a number greater than zero displayed for **spectrum strength**, the following is generally indicated: Below 25, the area-velocity return signal is very noisy. A number near 100 indicates the return signal is very clear. The typical range in most installations is from 40 to 100.

There are **two** important things to remember when interpreting these numbers:

- Is the current velocity value on the display accurate?
- Are these two numbers fairly consistent from one reading to the next?

If the level/flow readings are valid, you can assume the system is working and the signal and spectrum percentage values displayed here should be adequate. The values should not change more than 25% from one reading to the next. By contrast, numbers that vary widely from one reading interval to the next are indications of an unstable installation, and you should recheck the level/flow measurement.

If you press **Enter** again, the flow meter will display the system voltage:

SUPPLY VOLTAGE: XX.X

This value should be from 10.5 to 13.5 (volts DC). Note that if you do not press **Enter** after the first diagnostic menu appears, the flow meter will automatically advance the display through the next two screens and finally revert to the **Setup** menu after a short time-out.

YSI SOFTWARE REV: XX.X

Return to the **Setup** menu if the unit has not already done so. This time select **ENABLE/ALARM HYSTERESIS** from the menu. Press **Enter**. The following will appear:

LEVEL ENABLE/ALARM
HYSTERESIS X.XXX FT (or other units of measure)

The **HYSTERESIS** menu lets you set the range over which the level (or other condition) can vary before the flow meter responds to the change.

In the **PROGRAM** section of the software there are several steps that require a **change in a condition** to make the flow meter carry out certain actions. For example, **step 6** programs the flow meter to enable (activate) a sampler. In that step, you select a

condition (or set of conditions) that must occur before the sampler is enabled. You enter a value (level is an example) that must be met before the enabling occurs.

But what if this value is met and then falls away? It is possible for a condition to vary rapidly over a narrow range. Without hysteresis, the flow meter will turn the sampler off and on repeatedly, causing a condition known as *chattering*, that would result in very erratic operation of the sampler.

With hysteresis, you can enter a value that will keep the flow meter from responding to insignificant changes in the enabling condition. You should select a value for hysteresis that is narrow enough to allow the flow meter to respond to any serious change, but broad enough to ignore minor changes that could cause chattering. Press **Enter** and the following will appear:

```
VELOCITY ENABLE/ALARM
HYSTERESIS XX.XXX FT/S (or meters/second)
```

Press **Enter** again and the following will appear:

```
FLOW RATE ENABLE/ALARM
HYSTERESIS XX.XXX CFS (or other units of measure)
```

The next three menus may or may not appear, depending on other selections you make in **Program**. They concern alarm/enable hysteresis set points for parameter sensing—temperature, pH, D.O., and the YSI 600 Sonde outputs.

If you want to set hysteresis for any of these items, you should enable them when you work through the program section, then re-enter the **Setup** section (Hysteresis) and they will appear. Note that you can have temperature alone, or temperature with either pH or D.O., but you **must** have temperature with either pH or D.O.

Note

You cannot have pH and D.O. at the same time, and selection of one will prevent the other from appearing on the menus later.

The following will appear if you are measuring temperature:

```
TEMPERATURE ENABLE/ALARM
HYSTERESIS XX.XXX DEG F (or C)
```

The following will appear if you are measuring pH:

```
pH ENABLE/ALARM
HYSTERESIS X.XXX pH
```

The following will appear if you are measuring D. O.:

```
DO ENABLE/ALARM
HYSTERESIS X.XXX PPM
```

(or mg/l depending on units selected in Program.)

A set of menus similar to those shown above for pH, D.O., and temperature will then appear for the YSI 600 Sonde, if you have selected it. You can set hysteresis for YSI-pH, YSI-D.O., YSI-Conductivity, and YSI-temperature, if these parameters have been turned on in previous program selections.

2.4.2 Optional Outputs

After all the HYSTERESIS menus have been set, press **Enter**. The display will return to the Setup menu. This time, select OPTIONAL OUTPUTS with the **arrow key**. Press **Enter**.

OPTIONAL OUTPUTS •ANALOG OUTPUT ••SERIAL OUTPUT ••ALARM BOX •
--

ALARM BOX – refers to an external accessory used to signal alarms from flow meter measurements. See Section 5 for more information about the Alarm Box. Note that choice of SERIAL OUTPUT will eliminate ALARM BOX as an option. Likewise, choice of ALARM BOX will eliminate SERIAL OUTPUT as an option.

If you select any of these OPTIONAL OUTPUTS, the flow meter will request that you turn them on or off. If you are running on battery, select OFF for all unused outputs.

ANALOG OUTPUT – refers to the flow meter’s capability of managing associated equipment through a 4-20 mA current loop. The 4-20 mA current loop is a common method used to control industrial processes that are variable (rather than just fully off or on). At the lower value (4 mA) the control is turned off (0%); at 20 mA the control is completely turned on (100%). In between, rates range from 1 to 99%. A typical application is a chlorinator, which must vary in application of the chlorine gas as the amount of water passing through the system increases or decreases. Current ranges other than 4-20 mA are also in use, although they are less common than 4-20 mA. Examples are 0-20 mA (supported by the flow meter on the internal card only) and for longer current loops, 10-50 mA (not supported by the flow meter).

Teledyne Isco offers two different arrangements for the 4-20 mA control circuit. You can have either or both with the same flow meter. One arrangement requires the use of an external accessory, the **4-20 mA Output Interface** (see Section 4). This module connects to the flow meter and a source of AC power and contains the circuitry necessary to create the 4-20 mA current loop. This accessory connects to the flow meter through the **Interrogator** connector.

The other 4-20 mA option is a board installed inside the flow meter that contains circuitry for up to three separate, isolated 4-20 mA current loops. This option can also be ordered with one or two current loops supplied. If you use both the external converter and the internal board, you can have a total of four current loops controlled by the same flow meter. The internal current loops are brought out to a 6-pin M/S connector in the slot where the **Modem** connector is usually mounted.

To activate the internal analog output(s), return to the main screen and press **4, 2, 0**.

ANALOG CAPABLE ('0' TO DISABLE) OUTPUTS 3 (EXIT PROGRAM) WHEN DONE

Additional information for the internal analog output board, including specifications for the loops, is found in Section

Additional information for the internal analog output board, including specifications for the loops, is found in Section 4.3.2.

 CAUTION
--

Each 4-20 mA output represents a constant drain on the flow meter of at least 16 mA, whether activated or not. While 4-20 mA applications are generally made in installations with commercial power available, Teledyne Isco suggests the following for those who have a 4-20 mA output in a battery-powered installation.

Use with battery powered flow meters only:

- If the battery is continuously on charge (for example with a Solar Panel Battery Charger).
- If the battery is very large, such as a deep-cycle or marine type battery, or an Isco 55 Ampere-hour lead-acid battery.
- Use only one 4-20 mA output.
- Keep in mind that programming choices also affect power consumption. Use “minimum” settings on the flow meter whenever possible. (See Section 1, Table 1-6.)

Even with these circumstances, you may expect significantly shorter charge life from your battery. To determine the effect of this extra current draw on battery life, please refer to the section *How to Make Battery Calculations*, at the end of Section 1.

The following menus determine the behavior of the 4-20 mA current outputs. If you select ANALOG OUTPUT (another term for the 4-20 mA Output) and the flow meter is equipped with the optional internal board or the 4-20 mA external accessory has been turned on, RANGE, SMOOTHING, and MANUAL CONTROL will appear:

ANALOG OUTPUT • EXTERNAL 4-20 MA •• (RANGE) •• (SMOOTHING) ••
--

 CAUTION
--

If you do not have the proper hardware installed and you press 4 - 2 - 0 and the number of analog outputs is not **zero**, the external 4-20 mA converter will not work properly. If this occurs, return to the 4 - 2 - 0 option, and at the prompt enter **0** for the number of outputs activated. This will restore the external 4-20 mA converter capability.

MANUAL CONTROL will appear if you continue moving to the right. "RANGE" will appear with the ANALOG OUTPUT menu if the optional internal 4-20 mA converter is present in the flow meter. If you select RANGE, the following will appear:

OUTPUT RANGE • 0 - 20 mA • • 4-20 mA •

This menu lets you select the current value for zero percent (baseline) compatible with your equipment (internal 4-20 mA board only).

If you select SMOOTHING from the ANALOG OUTPUT menu the following will appear:

SMOOTHING • NONE • • 15 SEC • • 30 SEC • • 1 MIN •

The SMOOTHING option lets you stabilize operation of the outputs by preventing a rapid reaction to sudden sharp changes in the condition being monitored that quickly return to normal (transients). Selection of a smoothing interval will prevent the equipment controlled by the 4-20 mA loop from reacting too quickly, too much, or operating erratically. A low-pass filter algorithm is incorporated in the software.

If you select the MANUAL CONTROL option from the ANALOG OUTPUT menu the following will appear:

MANUAL CONTROL (OUTPUT 0 = EXTERNAL) OUTPUT 0 = 0.0 MA

This option lets you control the operation of a 4-20 mA loop to check the operation of equipment controlled by the loop at any level from 0 to 100%. After connecting a 4-20 mA output to a controlled device, you can program the flow meter to put a specified current on a specific analog output. If you are using the external 4-20 mA converter, the Analog Output number will be zero.

 Note

Selecting the MANUAL CONTROL option and programming any one of the ports will prevent the values transmitted by the other active 4-20 mA ports from being updated until the test is completed. The other ports will continue to transmit whatever value they held at the start of the test. Exiting from the MANUAL CONTROL menu at the end of the test will return all active 4-20 mA ports to normal operation.

Programming for the conditions and values that determine the operation of the 4-20 mA loop (or loops) is done in Programming Step 2, following the entry of FLOW RATE AT MAXIMUM HEAD.

 **Note**

The information in the following section is provided for those who can write their own software programs to process the data transmitted from the Serial Output port. Special cables may be required. Contact Teledyne Isco technical support for more information.

Serial Output – Returning to the OPTIONAL OUTPUTS menu, you will see the SERIAL OUTPUT option. This feature lets the flow meter transmit the most recent values for all currently enabled ports as ASCII text. You can then write a simple program to retrieve this data periodically, or you can do it interactively using a terminal program.

Command Line: (Use the INTERROGATOR connector.) The lines of text contain the port values for each port that is turned on. The DATA command will use a special command response protocol. The following table provides the ASCII codes for port types and standard units of measure.

Table 2-1 ASCII Output Codes		
Code	Parameter	Units
DE	Description	String
ID	Unit specific identifier	Unsigned long
MO	Model	String
TI	Time since 1900	Days
BV	Battery Voltage	Volts
LE	Level	Meters
LSI	Level Signal Strength	0 - 100%
FL	Flow	Cubic meters per second
VO	Volume	Cubic meters
FV	Forward volume	Cubic meters
RV	Reverse volume	Cubic meters
SV	Sampler Enabled Volume	Cubic Meters
RA	Rain (rolls over every 255 tips)	Tips
CR	Current day's rain (tips since midnight)	Tips
PR	Previous day's rain (tips since midnight)	Tips
PH	pH	pH units
DO	Dissolved Oxygen	Milligrams per liter
TE	Temperature	Degrees Celsius
YPH	YSI 600 pH	pH units
YDO	YSI Dissolved Oxygen	Milligrams per liters
YCO	YSI 600 Conductivity	Millisiemens per centimeter
YSP	YSI 600 Specific Conductance	Millisiemens per centimeter
YSA	YSI 600 Salinity	Parts per thousand
YTD	YSI 600 Total Dissolved Solids	Milligrams per liter

Table 2-1 ASCII Output Codes (Continued)

Code	Parameter	Units
YTE	YSI 600 Temperature	Degrees Celsius
YSP	YSI 600 Specific Conductance	Millisiemens per centimeter
YCO	YSI 600 Conductance	Millisiemens per centimeter
YSA	YSI 600 Total Salinity	Parts per thousand
YTD	YSI 600 Total Dissolved Solids	Milligrams per liter
YTE	YSI 600 Sonde Temperature	Degrees Celsius
SS	Sampler Enable Status	Logical
B?	Bottle Number and Time	Days
CS	Check sum (does not include the check sum, carriage return, and line feed)	Unsigned long

Note: The output string for a given flow meter will have values only for those parameters it is currently measuring. The order of the fields in this table is subject to change. Additional data types may be inserted anywhere in the list. Parsing routines for this output string should search by type identifier instead of depending on the position in the string. If an active port has an error flag set, the serial output will insert ERROR for the value.

You can enter the command line by connecting the interrogator cable with the interrogator sense line shorted to ground. Then send a series of '?' (question marks) until the flow meter transmits the unit's banner and prompt. The number of question marks necessary is a function of the baud rate auto detection. At the prompt, enter DATA<CR> and the flow meter will respond with the appropriate ASCII output string. You can send the DATA command as often as you want. Type 'Q' to leave the command response interface.

In addition to the port values, the data includes the flow meter's current time, the bottle number and time stamp of the three most recent sample events, the previous day's rainfall total (midnight to midnight), the current day's rainfall total since midnight, and a rainfall tips counter that rolls over every 255 tips. (See **Rain Gauge**.) The port values appear in a comma-separated values format. Each data field is preceded by a two or three-character type identifier. The table lists the type identifiers. Note that the flow meter's current time and the sample event time stamp appear as a number in standard spreadsheet format (days since 1900). The supported baud rates are 9600, 4800, 2400, and 1200 (no parity, eight bits and one stop bit).

Periodic Output: (Use a special RAIN GAUGE connector cable—contact the factory for assistance.) The periodic output will terminate during phone connection and when the interrogator cable is connected.

 **Note**

It is important to use CHECKSUM if you plan to use internal modems or the interrogator. The UART is shared with these devices.

If you select SERIAL OUTPUT from the OPTIONAL OUTPUTS menu, the following display will appear:

```
PERIODIC SERIAL OUTPUT
• ON •• OFF
```

Selection of OFF from this menu will disable this feature, and there will be no further references to it. The Serial Output data appears on the Interrogator connector of the flow meter. You should not use a standard interrogator cable for this application, as the sense line in the standard cable is shorted to ground. Selection of ON from this menu will enable the feature and cause the following display to appear:

```
SELECT BAUD RATE (N81)
• 9600 •• 4800 •• 2400 •• 1200 •
```

After you select the appropriate baud rate, the program will advance to the following menu:

```
SERIAL OUTPUT INTERVAL
• 15 SEC •• 1 MIN •• 5 MIN •• 15 MIN •
```

This menu lets you select how often the flow meter transmits the ASCII text string.

Following is an example of a string showing all options. In actual practice, there are no carriage returns in the text string.

```
DE, Theresa Street, ID,0721577657,
MO,4250,TI,35317.343715,BV,12.3,LE,0.1000,VE,0.1225,FL,
0.001555,VO,2.199325,FV,2.199325,RV,0.000000,SV,2.1955
39,SS,1,B0,35317.307384,B0,35317.269907,B0,35317.2325
93,CS,10819
```

If you select any of these outputs, the flow meter will request that you turn them on or off. If you are running on battery and do not need these options, select OFF. Otherwise, select ON. After the OPTIONAL OUTPUTS menus have been set, press **Enter**. The display will return to the SETUP menu.

The alarm box, also called the **High-Low Alarm Box**, allows you to operate control relays to signal alarms when flow rate rises above or falls below a certain set value. You can set both the high and low alarm values from 1 to 99% of the controlling condition. (See Section 5 for more information about the alarm box.)

If you select any of these outputs, the flow meter will request that you turn them on or off. If you are running on battery and do not intend to use either of these options, select OFF. Otherwise, select ON. After the OPTIONAL OUTPUTS menus have been set, press **Enter**. The display will return to the SETUP menu.

This time, select REPORT SETUP with the **arrow** key. Press **Enter**.

```
REPORT SETUP
• REPORT A •• REPORT B •
```

This step lets you determine the contents of the reports generated by the flow meter. The flow meter's report generator is capable of creating two different reports (A and B) that can be identical or quite different. The reason for two reports is to allow the summary of flow meter recording over different time periods. For example, you might generate report A weekly, and report B monthly. At this point we are only interested in selecting the items the flow meter will include in each report. Press **Enter** and the following will appear:

```
REPORT SETUP
• FLOW •• DO/PH •• YSI 600 •• SAMPLE HISTORY •
```

FLOW METER HISTORY is just off the screen, to the right. If you select FLOW and press **Enter**, the following will appear:

```
LEVEL IN REPORT
• YES •• NO •
```

Select YES if you want LEVEL to appear in the report, then press **Enter**. The following will appear:

```
FLOW RATE IN REPORT
• YES •• NO •
```

Select YES if you want FLOW RATE to appear in the report, then press **Enter** again. Then:

```
RAINFALL IN REPORT
• YES •• NO •
```

Select YES if you want RAINFALL to appear in the report. Note that you must have a rain gauge connected to the flow meter to sense rainfall occurrence. Press **Enter**. The following will appear:

```
REPORT SETUP
• FLOW •• DO/PH •• YSI 600 •• SAMPLE HISTORY •
```

FLOW METER HISTORY is off the screen to the right. Select DO/PH. Press **Enter**. The following will appear:

```
PH OR DO IN REPORT
• YES •• NO •
```

Select YES if you want DO/PH to appear in the report. Note that you must have the appropriate sensor connected to the flow meter to sense parameters; the flow meter is capable of sensing temperature, pH and temperature, and D.O. (dissolved oxygen) and temperature. Press **Enter**. The following will appear:

```
TEMPERATURE IN REPORT
• YES •• NO •
```

Select YES if you want TEMPERATURE to appear in the report. Press **Enter** again and the display will return to the REPORT SETUP menu:

```
REPORT SETUP
• FLOW •• DO/PH •• YSI 600 •• SAMPLE HISTORY •
```

FLOW METER HISTORY is just off the screen. Now select YSI 600. The following display will appear:

```
YSI DATA IN REPORT
• YES •• NO •
```

Press **Enter** again and the display will return to the REPORT SETUP menu.

```
REPORT SETUP
• FLOW •• DO/PH •• YSI 600 •• SAMPLE HISTORY •
```

This time select SAMPLE HISTORY. Press **Enter**. The following display will appear:

```
SAMPLE HISTORY IN REPORT
• YES •• NO •
```

Select YES if you want SAMPLE HISTORY to appear in the report. Press **Enter** again and the display will return to the REPORT SETUP menu:

```
REPORT SETUP
• DO/PH •• SAMPLE HISTORY •• YSI 600 •• FLOW METER
```

This time select FLOW METER HISTORY. Press **Enter**. The following will appear:

```
FLOW METER HISTORY IN REPORT
• YES •• NO •
```

Select YES if you want FLOW METER HISTORY to appear in the report. FLOW METER HISTORY is a list of the changes that have been made to the flow meter's program.

Press **Exit** to leave the program. Then press **Enter** and reselect SETUP. The **Setup** menu will reappear:

```
SETUP OPTIONS: 'EXIT' TO QUIT
• STATUS •• REPORT SETUP •• LCD BACKLIGHT •
```

SET CLOCK, SITE ID, MEASUREMENT SETUP, PROGRAM LOCK, PROGRAM are off-screen and can be reached with the **arrow** keys. Select LCD BACKLIGHT with the **arrow** key. Press **Enter**. The following will appear:

```
LCD BACKLIGHT MODE
• KEYPRESS TIMEOUT •• CONTINUOUS •• OFF •
```

KEYPRESS TIMEOUT will cause the backlight to be turned on whenever you press a key on the keypad (other than On and Off). An internal timer is started that will keep the backlight on for approximately two minutes after you press a key.

Each time you press a key, the timer is restarted, so the backlight will never go off as long as you continue to program the flow meter, with keystrokes coming less than two minutes apart. At the end of programming, the backlight will go out, and will stay out until you start to program again.

This feature is designed to conserve battery power by de-energizing the backlight when it is not needed. The backlight is still available if it is necessary to program in a dark environment, such as a manhole. We recommend using this selection if the flow meter is battery-powered, but installed in an environment where the lighting is poor.

CONTINUOUS will cause the backlight to be lit continuously. Where the flow meter is powered by an AC power supply, battery life considerations do not intervene. If the backlight makes the display easier to read, use it. Do not use CONTINUOUS in any installation that is battery-powered, as it will cause rapid discharge of the battery.

OFF will keep the backlight feature turned off under all circumstances. Select this option for maximum battery life in installations where there is sufficient ambient light to read the display without the backlight feature.

Press **Enter**. The SETUP menu will return. This time move the flashing cursor from LCD BACKLIGHT to LANGUAGE.

When LANGUAGE appears on your display, you may select an alternate language for programming. The other language depends on how the flow meter was ordered. The following display will appear:

```
LANGUAGE
• ENGLISH • • (second language, as ordered) •
```

Select the language appropriate for your application. The menus and the printed reports will appear in the selected language. Press **Enter**. The SETUP menu will reappear. This time select PROGRAM LOCK from the menu. Press **Enter**:

```
PROGRAM LOCK
• ON • • OFF •
```

PROGRAM LOCK keeps the program from being changed. Select OFF while you are programming, and then go back and select ON if you need to lock the program. At that, we suggest using the lock only if there are compelling security reasons.

Further changes will require entry of the password, which is the model number of the flow meter: **4250**. If you select ON, there is a time-out before the lock engages.

If you continue to work through the rest of the program, the lock will not engage until you are done. But if you stop programming longer than two minutes, the lock will engage, and you will not be able to make any further program changes.

Press **Enter** and the SETUP menu will reappear.

2.4.3 Step 1 - Program

```
SELECT OPTION
• PROGRAM •• SETUP •
```

PROGRAM will flash. (PROGRAM is always the default choice. That is because you are more likely to need to make changes in the PROGRAM section of the software than in the SETUP section.)

Note

If you choose NOT MEASURED for any selection, the flow meter will make no further reference to that function for the rest of the program, and you will be unable to activate that function later. If there is a feature you need that does not appear when the manual says it should, return to **step 1** and make sure you have not accidentally left it turned off.

If you program a parameter value as a condition for sampler enabling, pacing, dialout, etc., and then turn that parameter sensor off, the flow meter will also remove that condition from the program.

Consider all aspects of your program before you make any changes.

Press **Enter**. The following will appear:

```
UNITS OF LEVEL MEASUREMENT
• FT •• IN •• M •• MM •• NOT MEASURED •
```

Selection of feet, inches, meters, or mm depends on your situation. You would select NOT MEASURED if you were using the flow meter for some other form of sensing only, such as pH, or temperature. Press **Enter**. The following will appear. You will have to press the **right arrow** key several times to see all of the options displayed in the following menu:

```
FLOW RATE UNITS OF MEASURE
• GPS •• GPM •• GPH •• MGD •• CFS •• CFM •• CF-
```

Pressing the **right arrow** key several times will move other units onto the display.:

```
FLOW RATE UNITS OF MEASURE
••CFH •• CFD •• LPS •• M3S •• M3M •• M3H •• M3D •• AFD •
```

NOT MEASURED will also appear if you keep moving with the **right arrow** key. This step establishes the units of measure the flow meter will use in all subsequent displays and calculations.

GPS = gallons per second; GPM = gallons per minute; GPH = gallons per hour; MGD = millions of gallons per day; CFS = cubic feet per second; CFM = cubic feet per minute; CFH = cubic feet per hour; CFD = cubic feet per day; LPS = liters per second; M3S = cubic meters per second; M3M = cubic meters per minute; M3H = cubic meters per hour; M3D = cubic meters per day; AFD = acre-feet per day.

TOTALIZED VOLUME UNITS • GAL •• MGAL •• CF •• L •• M3 •• AF •
--

This step determines the units value the flow meter will use to record the totalized flow volume that passes by. GAL = gallons; MGAL = millions of gallons; CF = cubic feet; L = liters; M3 = cubic meters; AF = acre-feet.

VELOCITY UNITS • FT/S •• M/S •• NOT MEASURED•
--

This step determines the units the flow meter uses to record velocity. FT/S is feet per second; M/S is meters per second. If you do not want to use this feature, you would select NOT MEASURED.

For the next several substeps, you must have the appropriate sensor attached to the flow meter's **Parameter Port** or **Rain Gauge Port** (for the **Rain Gauge** or **YSI 600 Sonde**) to take advantage of the capabilities. You can only have D.O./temperature, pH/temperature or temperature alone on a given flow meter, unless you use the YSI 600 Sonde. The YSI 600 Sonde provides multiple outputs simultaneously. You can use the Rain Gauge with the YSI 600 sonde if you use a Y-connect cable.

The pH or D. O. probes do not attach directly to the flow meter, as their output signals are very low. You must also have the appropriate amplifier box connected between the probes and the flow meter.

<input checked="" type="checkbox"/> Note

The 270 D.O. module has been discontinued. Probes, service kits, and accessories are still available to maintain existing field units.

Remember that programming for one type of sensor will prevent the display of any references to the other in later program steps. All sensors but the rain gauge are mounted fully submerged in the flow stream. The pH and D.O. probes must be kept **constantly wet** or they can be damaged.

Their use in streams with intermittent flow (such as storm drainage) is not recommended. Note that the pH probe is a consumable item, and will eventually need replacement in any case.

RAIN GAUGE
• INCHES • • MM • • NOT MEASURED •

You must have an Isco **674 Rain Gauge** (or approved equivalent) connected to the flow meter through the **Rain Gauge Port** to sense rainfall. MM = millimeters. The rain gauge is factory-calibrated. See Section 4 for more information about the rain gauge. If you are not using a rain gauge, you would select NOT MEASURED for this step.

pH UNITS OF MEASURE
• pH • • NOT MEASURED •

pH measurement determines the relative acidity or alkalinity of a solution. You must have an Isco **pH Probe** (or approved equivalent) connected to the flow meter through the parameter port to sense pH. pH measurements range from 0 to 14 pH units, with solutions below 7 considered acidic and solutions above 7, alkaline. Pure water has a pH of 7.

These devices require periodic recalibration for accurate sensing of pH. See Section 4 for more information about the pH probe. If you are not using a pH probe you would select NOT MEASURED for this step.

- If you choose NOT MEASURED for pH, no more references to pH will appear for the rest of the program.
- If you select pH, you will be unable to measure D. O. and references to D.O. will not appear on the rest of the program.
- If your situation requires the measurement of both parameters (pH and D.O.) at the same time, or if you also need to measure conductivity, you should use the YSI 600 Multi-Parameter Sonde.

If you select NOT MEASURED and press **Enter**, the following will appear:

D. O. UNITS
• MG/L • • PPM • • NOT MEASURED •

Measurement of dissolved oxygen is conducted in studies of water quality in lakes and streams. Some dissolved oxygen is necessary for the survival of aquatic life in these waters.

You must have an Isco **Dissolved Oxygen Probe** (or approved equivalent) to sense dissolved oxygen. The probe attaches to the **Parameter Port**. These devices require periodic calibration for accurate sensing. See Section 4 for more information about the dissolved oxygen probe. PPM = parts per million; MG/L = milligrams per liter.

If you are not using the D. O. probe, you would select NOT MEASURED for this step.

Selection of PPM or MG/L will keep references to pH from showing up on subsequent menus.

TEMPERATURE UNITS
• DEG F •• DEG C •• (NOT MEASURED) •

This step sets up measurement of the temperature of the flow stream. You must have an Isco Temperature Probe (or approved equivalent) attached to the flow meter's Parameter Port. The temperature probe contains a thermistor and needs no further calibration. Measurement is in degrees Celsius or degrees Fahrenheit. If you are not using the temperature probe, you would select NOT MEASURED for this step.

Note that if you are using either the pH or D. O. probe, temperature *must* be measured; the NOT MEASURED option will not even appear.

YSI Sonde – The following series of menus concerns the use of the YSI 600 Multi-Parameter Sonde. This probe allows you to measure several different characteristics of a flow stream at the same time. The YSI 600 Sonde attaches to the Rain Gauge connector on the 4250. This connector must be a special, modified connector with nine pins.

Note

4250 Flow Meters with 4-pin Rain Gauge connectors cannot support the YSI 600. It is necessary to return the flow meter to the factory for modifications if you wish to use a YSI 600 Sonde. In addition to the connector, there are significant internal modifications to the flow meter's electronics and software.

You can use both the YSI Sonde and a Rain Gauge on flow meters that support the YSI with a special Y-connect cable. Note that the YSI 600 Sonde differs from the previously-mentioned pH and D.O. probes. The YSI 600 can measure pH and D.O. at the same time, as well as temperature and conductivity. If you are not using the YSI 600 sonde, select NO in the following display and the flow meter will advance to the next step. Otherwise, select YES.

YSI 600 CONNECTED
• YES •• NO •

- If you select NO, you will be unable to activate the YSI Sonde later in the program.

If no communication has been confirmed, the following display will appear:

YSI COMMUNICATIONS CHECK
• YES •• NO •

NO is the default. If you select YES, the following display will appear:

WARNING – DO NOT DISCONNECT POWER
YSI COMMUNICATION CHECK. PLEASE WAIT...

 **CAUTION**

Do not disconnect either sonde or flow meter power during a communications check. The memory in the sonde can be damaged by a power failure during an update.

If the communication check is bad, the following display will appear:

COMMUNICATIONS CHECK FAILED
PRESS ENTER TO CONTINUE

 **Note**

The flow meter cannot communicate at 600 baud. If your sonde has been set up for 600 baud, you will get a communications failure. Consult the YSI 600 Manual for what to do in this case.

If the communications check is good, the following display will appear:

COMMUNICATIONS RATE SET AT 2400 BAUD
PRESS ENTER TO CONTINUE

After you press **Enter**, the flow meter will advance to the following display:

YSI 600 pH UNITS OF MEASURE
• pH • • NOT MEASURED •

- Selection of NOT MEASURED from any of the YSI menus will prevent you from activating that function later in the program.

If you wish to make use of the YSI 600 sonde's pH measurement capability, select pH. If you do not, select NOT MEASURED.

YSI 600 D.O. UNITS OF MEASURE
• MG/L • • NOT MEASURED •

If you wish to make use of the YSI 600 sonde's D.O. measurement capability, select MG/L. Otherwise, select NOT MEASURED.

YSI 600 CONDUCTIVITY PARAMETER
• YSI SP COND • • YSI SALINITY • • YSI CONDUCTIVITY • >

For any of the YSI CONDUCTIVITY options, if you press **Enter**, the following display will appear:

TEMPERATURE COEFFICIENT
1.91%

This value is provided because conductivity rises (~2%/ °C) with temperature. The default setting is 1.91%. This value is the temperature coefficient for pure KCl (potassium chloride) in water. For other salts this value will be somewhat inaccurate, but it does provide a close approximation for solutions of many common salts, such as NaCl (sodium chloride), NH₄Cl (ammonium

chloride) and sea water. If you use the value of 1.91, in most cases you will be able to identify that gross changes are occurring in the ionic content of the stream. If you move with the **right arrow**, the following options will appear on the display:

YSI 600 CONDUCTIVITY PARAMETER
• YSI T.D.S. • • NOT MEASURED •

T.D.S. stands for “total dissolved solids.” T.D.S. are measured in parts per thousand (ppt).

TDS SCALE FACTOR
0.75

Total dissolved solids are estimated by multiplying conductivity by an empirical factor. This factor can vary between 0.55 and 0.9 depending on the solubility of the ions in the water and its temperature.

YSI 600 TEMPERATURE UNITS
• °F • • °C • • NOT MEASURED •

Select the appropriate temperature units.

2.4.4 Step 2 - Flow Conversion (Area Velocity Only)

Flow conversion is the method the flow meter uses to calculate flow rate from the measurement of the area and velocity of the flow stream.

Note

Accurate measurements of both area and level are essential for accurate flow compilation. See **Section 3.6, Area Velocity Sensor Installation.**

The 4250 can calculate flow either through area-velocity measurements and area-velocity data points, or through level-to-flow rate conversions using a standard primary measuring device or level-to-flow rate data points.

If you wish to use the 4250 with a primary measuring device, skip to **Step 2 - Flow Conversion (Level-to-Flow Rate)** following this section.

FLOW CALCULATION
• AREA VELOCITY • • LEVEL TO FLOW RATE •

If you select Area Velocity the following will appear:

AREA VELOCITY CALCULATION
• CHANNEL SHAPE • • DATA POINTS •

CHANNEL SHAPE uses the shape of the channel to calculate the flow rate. DATA POINTS allows you to enter your own measurements of area and velocity and the flow meter will calculate flow rate based on your data. For now, select CHANNEL SHAPE.

After you press **Enter**, the following display will appear:

```
AREA VELOCITY - CHANNEL SHAPE
• ROUND PIPE • U-CHANNEL • RECTANGULAR • >
```

(You will have to use the arrow key to bring TRAPEZOIDAL onto the screen.) Select ROUND PIPE.

Note

Where the program requests the dimension of a channel, *measure* the channel for accuracy. Do not rely on “nominal” dimensions or specifications.

Press **Enter**. The following will appear:

```
VELOCITY ROUND PIPE
DIAMETER = X.XXX FT (or meters)
```

If you select U-CHANNEL, the following will appear:

```
VELOCITY U-CHANNEL
WIDTH = X.XXX FT (or meters)
```

If you select RECTANGULAR, this will appear:

```
VELOCITY RECTANGULAR
WIDTH = X.XXX FT (or meters)
```

If you select TRAPEZOIDAL, this will appear:

```
VELOCITY TRAPEZOID
TOP WIDTH = X.XXX FT (or meters)
```

Press **Enter**. The following display will appear:

```
VELOCITY TRAPEZOID
BOTTOM WIDTH = X.XXX FT (or meters)
```

Exit the program. Re-enter and advance to the AREA VELOCITY menu as follows:

```
AREA VELOCITY CALCULATION
• VELOCITY •• DATA POINTS •
```

This time, select DATA POINTS. Press Enter. The following display will appear:

```
DATA POINT SET
• ONE •• TWO •• THREE •• FOUR •• (NONE) •
```

In general, the option of NONE will not show up on the display. For the 4250, you can define the four sets of data points as either level-to-flow rate data points or level-to-area data points. (Level-to-area data points are used in 4250 applications where the channel has an unusual or non-standard shape.) If, for example, you had defined all four sets as level-to-flow rate sets, and then wanted to define a set as level-to-area, NONE would appear to tell you that no sets were available to define as level-to-area data points.

To get out of this situation, you would have to exit and then go back to the menu where you defined the data points as level-to-flow rate data points. When you reach that menu you would select CLEAR to erase the set in the flow meter's memory. Then you could redefine the data set as a level-to-area set. After you select ONE and press **Enter**, the following display will appear: (if you have not previously entered any data points to the set.):

```
LEVEL UNITS FOR DATA POINT ENTRY
• FT • IN • M • MM •
```

Select one. Press **Enter**. The next display requests selection of units of measure for flow rate:

```
FLOW RATE UNITS
• GPM • GPS • MGD • CFS • CFM • M3S • M3H • M3D •
```

If you press the right arrow key several times, the following units will appear on the display:

```
FLOW RATE UNITS
• LPS • CFD • GPH • AFD • CFH • CFM • M3M •
```

Make your selection. Then:

```
SET 1: 0 POINTS ENTERED
• ADD POINT • (UNITS...) •
```

(...if the set is empty.)

Only ADD POINT and UNITS will appear if you have not entered any points into a data set. Once you have defined UNITS and added some points, the UNITS option will disappear from the screen. (You cannot change the units of measure after you have begun a set).

```
SET 1 DATA POINT 1 'EXIT' TO QUIT
ENTER: 0.00 FT 0.000 FT2
```

(Other units of measure may appear, depending on what you chose previously)

Enter values appropriate for what you have measured. When you have entered all the points for a data set, press **Exit**. The following will appear:

```
SET 1: X POINTS ENTERED
• (USE) • EDIT POINT • CLEAR • PRINT • SAVE •
```

(USE will not appear until you have entered at least four points.)

(USE), EDIT POINT, CLEAR, PRINT, and SAVE all let you manipulate the data points you have entered. USE tells the flow meter to generate a flow profile based on the data set you have entered. You need at least four data points in one set for the flow meter to calculate a valid flow profile for the stream.

EDIT POINT allows you to change the value of a data point you have already entered.

CLEAR erases an entire data point set from the flow meter's memory.

PRINT allows you to print the entire contents of a data point set you have entered on the flow meter's internal printer.

SAVE instructs the flow meter to save a set of data points as you have entered it.

If you select EDIT POINT, the flow meter will display the following:

```
ENTER POINT NUMBER TO EDIT
POINT NUMBER TO EDIT: X
```

Enter the number of the data point you want to change, **not the value of it**. Press **Enter**.

The following display will appear:

```
SET X DATA POINT X 'EXIT' TO QUIT
ENTER: X.XX (level units) X.XX (area units)
```

After you have entered all the data points, the flow meter will request that you enter a value for MAXIMUM HEAD and MAXIMUM FLOW. The flow meter uses this value to calculate the flow profile for the stream. You must know what the maximum head for your flow stream is. You should enter a value that is reasonable for your own application, rather than the largest value possible. The flow calculation is based on this value.

2.4.5 Step 2 - Flow Conversion (Level-to-Flow Rate)

Use this flow conversion only if you do not wish to calculate flow from area and velocity. Normally, the 4250 is used in area-velocity installations. This selection allows you to use the 4250 with a primary measuring device, Manning applications, a custom flow equation, or data points.

```
FLOW CONVERSION TYPE
•WEIR/FLUME •• EQUATION •• MANNING •• DATA POINTS •
```

WEIR/FLUME = weir or flume; EQUATION = equation; MANNING = Manning; DATA POINTS = data points.

If you select WEIR/FLUME, the following will appear:

```
TYPE OF DEVICE:
• WEIR •• FLUME •
```

For detailed information on weirs and flumes, refer to the *Isco Flow Measurement Handbook*. Consulting the manufacturer of the specific weir or flume is also worthwhile. Note that for weirs and flumes, there is a preferred location for installing the level measuring device. Proper mounting of the level measurement device and accurate measurement of the level in the flow stream

at the calibration point are essential for accurate flow calculation by the flow meter. If you select WEIR, the following display will appear:

SELECT TYPE OF WEIR:
• V-NOTCH •• RECTANGULAR •• CIPOLLETTI •

If you select V-NOTCH, the following will appear:

SELECT V-NOTCH WEIR ANGLE (IN DEGREES)
• 22.5 •• 30 •• 45 •• 60 •• 90 •• 120 •

If you select RECTANGULAR, the following will appear:

END CONTRACTIONS ON RECTANGULAR WEIR:
• YES •• NO •

If you select YES, the following will appear:

RECTANGULAR WEIR WITH END CONTRACTIONS
ENTER CREST LENGTH XX.XXX FEET (*or meters*)

If you select CIPOLLETTI, the following will appear:

CIPOLLETTI WEIR
ENTER CREST LENGTH XX.XXX FEET (*or meters*)

If you selected FLUME for the type of standard device, the following display will appear:

SELECT TYPE OF FLUME
• PARSHALL •• PALMER-BOWLUS •• LEOPOLD-LAGCO •

Also available with the **arrow** key:

SELECT TYPE OF FLUME
• HS •• H •• HL •• TRAPEZOIDAL •

If you select PARSHALL, the following will appear:

SELECT PARSHALL SIZE:
• 1" •• 2" •• 3" •• 6" •• 9" •• 1.0' •• 1.5' •• 2.0' •

If you press the **right arrow** key several times, the sizes shown below will move onto the screen:

SELECT PARSHALL SIZE:
• 3' •• 4' •• 5' •• 6' •• 8' •• 10' •• 12' •

If you select PALMER-BOWLUS, this will appear:

SELECT PALMER-BOWLUS SIZE
• 4" •• 6" •• 8" •• 9" •• 10" •• 12" •• 15" •• 18" •• 21" •

If you press the **right arrow** key several times, the sizes shown below will move onto the screen:

```
SELECT PALMER-BOWLUS SIZE
• 24" •• 27" •• 30" •• 48" •
```

If you select LEOPOLD-LAGCO, this will appear:

```
LEOPOLD-LAGCO FLUME SIZE
• 4" •• 6" •• 8" •• 10" •• 12" •• 15" •• 18" •• 21" •
```

If you press the **right arrow** key several times, the sizes shown below will move onto the screen:

```
LEOPOLD-LAGCO FLUME SIZE
• 24" •• 30" •
```

If you select HS, the following display will appear:

```
HS FLUME SIZE
• 0.4' •• 0.5' •• 0.6' •• 0.8' •• 1.0' •
```

If you select H, the following will appear:

```
H FLUME SIZE
• 5' •• .75' •• 1' •• 2' •• 2.5' •• 3' •• 4.5' •
```

If you select HL, the following will appear:

```
HL FLUME SIZE
• 2.0' •• 2.5' •• 3.0' •• 3.5' •• 4.0' •
```

If you select TRAPEZOIDAL, this will appear:

```
TRAPEZOIDAL SIZE
• LG 60 V •• 2" 45 WSC •• 12" 45 SRCRC •
```

This completes the section on WEIR/FLUME flow conversions.

Returning to **Step 2**, SELECT FLOW CONVERSION: If you select EQUATION the following will appear:

```
ENTER EQUATION UNITS
Q = XXX.XXXH^X.XX + XXX.XXXH^X.XX
```

This step allows you to enter an equation that is appropriate for your flow situation. The equation is expressed in the general form of $Q = k_1H^{P_1} + k_2H^{P_2}$, where Q = flow rate, k_1 = a constant, H = level or head, and P_1 is the power to which H is raised. k_2 and P_2 are a second constant and power found in some equations. If your equation has only one term, you should enter **0** for the second constant.

Returning to **Step 2**, SELECT FLOW CONVERSION, if you select MANNING, the following will appear:

```
SELECT MANNING TYPE
• ROUND PIPE •• U-CHANNEL, RECTANGULAR •• T-
```

TRAPEZOIDAL is also available, if you move to the right with the **right arrow** key.

If you select ROUND PIPE for the Manning flow conversion, the following displays will appear:

```
MANNING ROUND PIPE
SLOPE = X.XXXXXX ROUGH = X.XXXX
```

Slope is entered as a dimensionless quantity, delta Y/ delta X, *not* as percent slope. Or, as otherwise expressed:

$$\frac{\Delta X}{\Delta Y} = \frac{\text{Rise}}{\text{Run}}$$

For example: $\frac{1}{100} = .01$

Roughness coefficients are published in the *Isco Open Channel Flow Measurement Handbook*. You must know the material the pipe is made of. The roughness coefficients are published for all common materials in three grades: minimum, normal and maximum. Then:

```
MANNING ROUND PIPE
DIAMETER = X.XXX FEET (or meters)
```

If you select U-CHANNEL for the Manning flow conversion, the following displays will appear:

```
MANNING U-CHANNEL
SLOPE = X.XXXXXX ROUGH = X.XXX
```

(

Slope and roughness are entered as for ROUND PIPE previously.) Then:

```
MANNING U-CHANNEL
WIDTH = X.XXX FEET (or meters)
```

If you select RECTANGULAR for the Manning flow conversion, the following displays will appear:

```
MANNING RECTANGULAR
SLOPE=X.XXXXXX ROUGH=X.XXX
```

(Slope and roughness are entered the same as for ROUND PIPE previously.) Then:

MANNING RECTANGULAR
WIDTH=X.XXX FEET (or meters)

If you select TRAPEZOID for the Manning flow conversion, the following displays will appear:

MANNING TRAPEZOID
SLOPE=X.XXXXXX ROUGH=X.XXX

(Slope and roughness are entered as for ROUND PIPE previously.) Then:

MANNING TRAPEZOID
TOP WIDTH=X.XXX FEET (or meters)

Then:

MANNING TRAPEZOID
BOTTOM WIDTH=X.XXX FEET (or meters)

Returning to **Step 2**, FLOW CONVERSION TYPE, if you select DATA POINTS, the following will appear:

SELECT DATA SET
• ONE •• TWO •• THREE •• FOUR •• (NONE) •

Then:

LEVEL UNITS FOR DATA POINT ENTRY
• FT •• IN •• M •• MM •

This allows you to enter data points that are in different units than what you are using. Then:

FLOW RATE UNITS
• GPM •• GPS •• MGD •• CFS •• CFM •• M3S •• M3H •• M3D •

If you press the **right arrow** key several times, the following units will appear on the display:

FLOW RATE UNITS
• LPS •• CFD •• GPH •• AFD •• CFH •• CFM •• M3M •

GPM = gallons per minute; GPS = gallons per second, MGD = million gallons per day, CFS = cubic feet per second; CFM = cubic feet per minute, M3S = cubic meters per second; M3M = cubic meters per minute; M3H = cubic meters per hour; M3D = cubic meters per day; LPS = liters per second; CFD = cubic feet per day; GPH = gallons per hour; AFD = acre-feet per day; CFH = cubic feet per hour.

DATA POINT flow conversion allows you to enter measured level and flow rate values for a number of different points. The 4250 Flow Meter can accept up to four sets of data points with each set containing as many as fifty points.

The flow meter then performs a three-point interpolation to calculate a flow rate appropriate for the data entered. The common use of data point flow conversion is with unusual primary measuring devices, specifically devices that the 4250 does not support in the WEIR/FLUME flow conversion set.

The level-to-flow rate data for such devices is usually available from the manufacturer. From this data the flow meter can create a flow conversion based on the relationship between the level and flow rate. After the FLOW RATE UNITS menu has appeared, the next menu is:

```
SET X (1-4): (0) POINTS ENTERED
• ADD POINT •• (UNITS) •
```

Then:

```
SET 1 DATA POINT 1
ENTER: 0.00 (level units) 0.000 (units of volume)
```

After you have entered the data point set the following will appear:

```
SET X (1-4): XX (1-50) POINTS ENTERED
• (USE) •• EDIT POINT •• ADD POINT •• CLEAR •• PRINT •
```

UNITS, SAVE will also appear if you move the flashing cursor with the right arrow key. USE will only appear after four points have been entered. USE tells the flow meter that the set is complete and can be used for the flow rate calculation.

Select EDIT POINT if you need to change either the level or the flow value for a particular data point.

Select ADD POINT if you want to add another point to a data set.

CLEAR will erase an entire set of data points from the flow meter's memory.

PRINT will make the flow meter print out the entire data set.

UNITS allows you to set or change the units of measure used in the data set. Note that you can only set UNITS if the set is empty, or you have cleared it. You cannot change the units once you have entered data points into a set unless you clear it and start over.

SAVE tells the flow meter to save the data set as it is.

If you select either EDIT POINT or ADD POINT, the following display will appear:

```
SET X (1-4) DATA POINT XX (1-50)
ENTER: XX.XX (level units) XXX.XXX (volume)
```

Enter Maximum Head

Before advancing from **step 2** (Flow Conversion) to **step 3** (Adjust Parameters), the flow meter will request that you enter a value for **Maximum Head** (Level) for the device or flow conversion you are using.

For most standard measuring devices this information is published or is available from the device manufacturer. Note that you should *not* arbitrarily use the largest value available. Instead, use the value that is the **largest expected level** for your actual situation, even if this is less than the published maximum.

The flow meter's internal resolution and its accuracy are based on the value you enter for Maximum Head. The flow meter will display:

FLOW RATE AT MAXIMUM HEAD X.XXX CFS (or other units of measure)
--

Programming the 4-20 mA Outputs

<input checked="" type="checkbox"/> Note

If you do not turn on the 4-20 mA output(s) in step 1, the menus determining its (their) operation will not even appear later in the program. If you need this function and cannot find the appropriate menus in **step 2**, return to **step 1, Setup** and check to see that you have not inadvertently switched the option off.

If you turn on any of the 4-20 mA outputs (ANALOG OUTPUTS) in **step 1- Setup**, programming the actual operation of the output appears in **step 2 - Select Flow Conversion**. For each 4-20 mA output port turned on, the flow meter will request entry of the type of data that will drive the output, along with minimum and maximum values. Here is an example of what you might see for programming analog output 1.

DATA TYPE FOR ANALOG OUTPUT 1 • (OFF)•(LEVEL)•(FLOW RATE)•(VELOCITY)•(pH)•

TEMPERATURE, DISSOLVED OXYGEN, CONDUCTIVITY, SPECIFIC CONDUCTANCE, SALINITY, and TOTAL DISSOLVED SOLIDS may also appear as driving conditions.

The actual choices available to you will depend on what ports you have turned on previously and what accessories (YSI, pH, DO probes, rain gauge, etc.) you are using with your flow meter. After you select one of the choices available to you, the flow meter will request that you enter minimum and maximum values for that choice:

ANALOG OUTPUT PORT 1 4 MA = X.X (units)
--

Note that 4 MA in the second line of the display could also be 0 MA if that is what you selected for the current loop minimum in **Setup**. The units are the units of measure appropriate for the option you selected; for example, *feet* or *meters* for level, *degrees F*

or *C* for temperature, *mg/L* for dissolved oxygen, etc. After you have set the minimum value for the port, the flow meter will request you to enter a value for full-scale, or 100%:

ANALOG OUTPUT PORT 1 20 MA = <i>X.X</i> (<i>units</i>)

This value causes the port to transmit 100% or 20 mA. For example if the data type selected for this output were level, and the unit is measuring level in a four-foot pipe, you would enter a full-scale value of four feet. If the actual level reading is currently two feet, the analog output would read 12 mA (50% if the 4-20 mA current range is selected) or 10 mA (50% if the 0-20 mA current range is selected). The flow meter will then request that you repeat the process of defining the data type and setting the minimum and maximum values for any of the other analog ports you activated previously in **Setup**.

2.4.6 Step 3 - Parameter to Adjust

This step lets you enter the measured level in the flow stream. It also lets you calibrate the pH (acidity or alkalinity), D.O. (dissolved oxygen) parameter sensors, and the YSI 600 Multiple Parameter Sonde. Note that there is no calibration step for the temperature sensor because it does not need calibration. When you select **step 3** the following will appear:

PARAMETER TO ADJUST • NONE •• (LEVEL) •• (pH) •• (D. O.) •• (YSI 600) •
--

LEVEL will not show up if you are using the flow meter only for parameter sensing. Likewise, pH and/or D. O. and YSI 600 will not show up on the display if you have locked them out by programming selections you made in **step 1**.

Remember that selection of *either* pH or D. O. in **step 1** will keep the other from appearing on the display in this or subsequent programming steps. If the parameter you want does not appear in this menu, exit the program and return to **Setup**. Check to see that you have not accidentally locked your choice out with selections you made in the early section of the program. If you select NONE, the flow meter will advance to the next step. If you select LEVEL, the following will appear:

ENTER CURRENT LEVEL <i>X.XXX</i> FEET (<i>or meters</i>)

First measure the level in the flow stream. This is usually done with either a measuring stick. Generally, you should measure the level **upstream** from the AV sensor. The sensor should be installed in an area of **stable flow**.

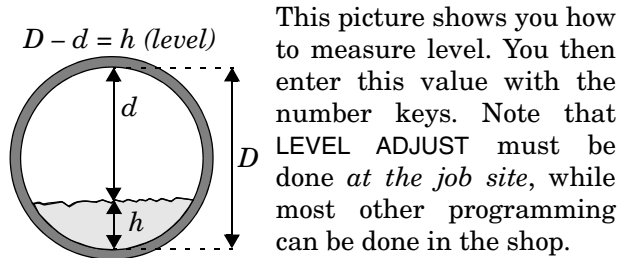

Figure 2-4 Measuring Level in Round Pipes

You should remove the sensor and mounting ring to measure the level if either of the following occur:

- If it is not possible to measure the level upstream when the sensor is installed (cramped quarters inside smaller pipes).
- If the sensor and its mounting ring create a visible “jump” in the stream.

This “jump” would be any noticeable disturbance on the surface of the flow stream where it passes over the sensor and mounting ring, and is typical of lower flows. See Section 3.6 for more information. Enter this value with the number keys. LEVEL ADJUST must be done **at the job site**, while most other programming can be done in the shop. Unless you have reliable information about the size of the channel, you should measure that, also.

Note

It is very important to enter accurate measurements for both the level in the stream and the dimension(s) of the channel, as all calculations of flow will be based on these measurements. If the values entered are incorrect, even by relatively small amounts, all subsequent flow calculations will also be incorrect. For example, an error of only $\frac{1}{4}$ " for a 3" level and $\frac{1}{4}$ " for a 10" diameter round pipe can result in a combined error of over 14%!

Errors in level measurement have a greater effect on flow calculations at low liquid levels. Dimensional errors tend to be more significant at higher levels.

If you select pH for Parameter to Adjust, the following display will appear. (pH will not appear as an option unless you have selected it in **step 1**.) If you want to measure pH and pH does not appear in this step, you must go back to **step 1** and select pH instead of NOT MEASURED.

pH CALIBRATION
• pH 4 & 7 • • pH 7 & 10 • • pH 4, 7, & 10 •

You can perform a two- or three-point calibration for pH with the pH sensor. Select the calibration that best suits your stream’s profile. If the pH in your stream is generally below 7, you would

probably select pH 4 & 7. If the pH is generally above 7, you would probably select pH 7 & 10. If your stream's pH varies a great deal, say from 3 to 12, your best choice would be pH 4, 7, & 10. Then:

```
RINSE PROBE AND PLACE IN 4.0 pH SOLUTION
PRESS ENTER WHEN STABLE  X.XX pH
```

The flow meter will direct you to repeat this process with the other standard buffers (7 and/or 10) to calibrate the pH sensor. If the probe fails to provide the correct output with any of the buffer solutions, you will receive the following message:

```
pH BUFFER/PROBE OUT OF RANGE
PRESS ENTER TO CONTINUE
```

If you select D. O. for Parameter to Adjust, the following display will appear:

```
DISSOLVED OXYGEN CALIBRATION
•D.O. STANDARD•ABS BAROMETRIC PRESSURE•>
```

ALTITUDE is just off screen to the right. If you select D.O. STANDARD for the calibration method, the following display will appear:

```
D.O. STANDARD
0.00 MG/L
```

If you select ABS (absolute) BAROMETRIC PRESSURE the following will appear:

```
ABS BAROMETRIC PRESSURE
X.XX mmHg
```

Absolute barometric pressure is barometric pressure not corrected to sea level. The barometric pressure published by the U.S. Weather Bureau is adjusted to sea level. If you use their value, you must convert it to the absolute pressure for your altitude. You should use Weather Bureau barometric pressure only if you are at sea level, or are able to correct the Weather Bureau figure to absolute pressure at your location. Enter the correct value.

```
WRAP D. O. PROBE IN MOIST CLOTH
PRESS ENTER WHEN STABLE: X.XX MS/CM:
```

Then the display will advance to the following:

```
CALIBRATING...
PLEASE WAIT...
```

If you select ALTITUDE for D.O., this will appear:

```
UNITS FOR ALTITUDE ENTRY
• FT •• M •
```

Select the appropriate units and press **Enter**.

```
ALTITUDE
ALTITUDE = X.XX FT (or meters)
```

Enter the altitude for your location. Then:

```
WRAP D. O. PROBE IN MOIST CLOTH
PRESS ENTER WHEN STABLE: X.XXX MG/L
```

For more detailed information on the pH and D. O. probes, see Section 4.

Returning to **step 3**, Parameter to Adjust, the following display will appear:

```
PARAMETER TO ADJUST
• NONE •• (LEVEL) •• (pH) •• (DO) •• (YSI 600) •
```

Note

If you are using the YSI Sonde and YSI 600 does not appear on your display, return to **step 1**, Program, and make sure you have selected YES from the YSI CONNECTED menu.

If you select YSI 600, the following will appear:

```
YSI 600 PARAMETER TO CALIBRATE
• NONE •• pH •• DO •• CONDUCTIVITY •
```

If you select pH for the parameter to calibrate, the following display will appear:

```
YSI 600 pH CALIBRATION
• pH 4 & 7 •• pH 7 & 10 •• pH 4, 7, & 10 •
```

You can perform a two- or three-point calibration for pH with the YSI sonde. The menus that follow are similar to those in the preceding section for the Isco pH sensor. Select the calibration that best suits your stream's profile. When you complete the pH calibration successfully, the following display will appear:

```
CALIBRATING...
PRESS ENTER TO CONTINUE
```

Returning to the YSI menu, if you select D.O.:

```
YSI 600 DISSOLVED OXYGEN CALIBRATION
• D.O. STANDARD •• ABS BAROMETRIC PRESSURE •>
```

ALTITUDE is just off screen to the right. Programming for YSI 600 D.O. is essentially the same as that described for the Isco D.O. sensor on the preceding section, with the exception that you always place the sensor in a cup, rather than wrap a moist cloth around it as is done for the Isco D. O. sensor.

If you select CONDUCTIVITY for the parameter to calibrate, the following display will appear:

```
CONDUCTIVITY CALIBRATION UNITS
• MS/CM • • PPT •
```

MS/CM is milli-siemens per centimeter. The *siemen* is the S.I. (*Système Internationale*) name for the unit of conductance, which is also the reciprocal of the *ohm*. The siemen was formerly called the *mho* (*ohm* spelled backwards), and that term may be more familiar to some. PPT is *parts per thousand*. Select the standard most suitable for your application.

```
CONDUCTIVITY STANDARD
X.XX MS/CM
```

Then:

```
PLACE PROBE IN X.XX MS/CM
PRESS ENTER WHEN STABLE: X.XX MS/CM
```

Then:

```
CALIBRATING...
PLEASE WAIT...
```

If you select PPT for the conductivity standard:

```
CONDUCTIVITY STANDARD
X.XX PPT
```

Then:

```
PLACE PROBE IN X.XX PPT
PRESS ENTER WHEN STABLE: X.XX MS/CM
```

Then:

```
CALIBRATING...
PLEASE WAIT...
```

There is no need to calibrate the YSI 600 temperature sensor, as it is self-calibrating.

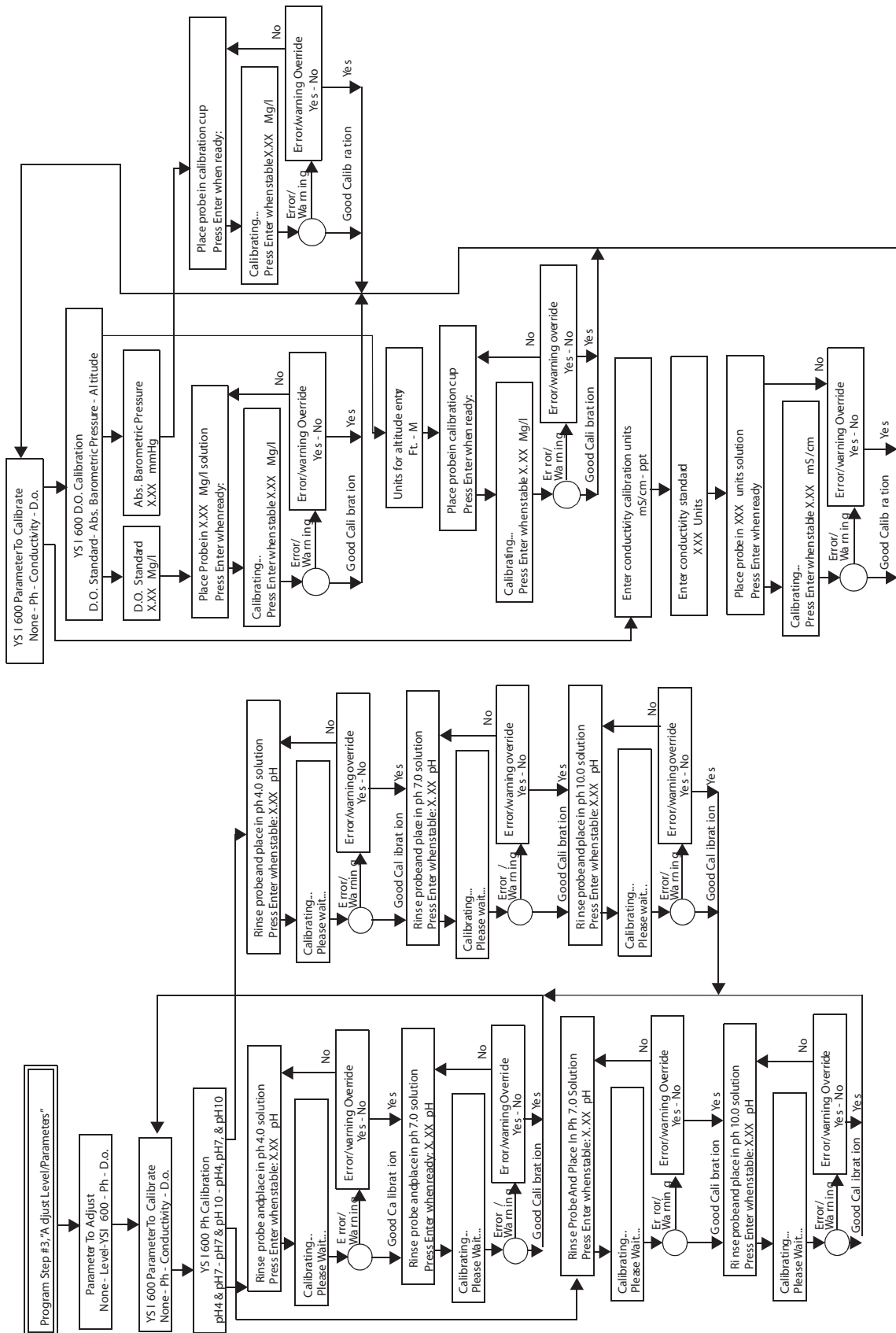

Figure 2-5 YSI 600 Sonde Calibration Flow Chart

2.4.7 Step 4 - Reset Totalizer

If you select **step 4**, the following will appear:

```
RESET TOTALIZER
• YES •• NO •
```

This step allows you to reset the flow meter's internal flow totalizers. All models have the capability of maintaining a separate totalizer for the time the sampler is enabled through the **sampler enabling** feature (**step 6**). The 4250 flow meter, because it can measure forward and reverse flows, maintains **three separate totalizers**: a separate totalizer for **each direction** and a totalizer for the **difference** between forward and reverse flows.

If you select NO, the flow meter will advance to the next step. If you select YES, the flow meter will reset the internal totalizer to zero.

```
FLOW TOTALIZER: XX CF
FORWARD XX REVERSE X CF
```

Then, if you have sampler enabling turned on (**step 6**), the flow meter will ask you whether you want to reset the totalizer for the total flow during the time the sampler was enabled. (See **step 6** for an explanation of sampler enabling.)

```
ENABLE TOTALIZER XX CF (or other units of measure)
PRESS 'ENTER
```

Then:

```
RESET SAMPLER ENABLE TOTALIZER
• YES •• NO •
```

2.4.8 Step 5 - Sampler Pacing

If you select **step 5**, the following will appear:

```
SAMPLER PACING
• DISABLE •• (VOLUME) •• (FLOWLINK) •• CONDITIONAL •
```

This step determines how the flow meter will signal an associated automatic wastewater sampler to take a sample. The flow meter and sampler must be connected together with a cable. The flow meter sends flow pulses to the sampler. The sampler uses these flow pulses as counts. When an appropriate number of flow pulses has been received by the sampler, it will take a sample.

VOLUME will not appear if the flow meter is measuring level only, or is only being used for parameter monitoring.

The Flowlink menu option will not appear unless Flowlink software is installed and pacing has been downloaded from Flowlink.

If you select DISABLE for sampler pacing, the flow meter will be effectively disconnected from the sampler. The sampler will run its program as if there were no flow meter. Selection of DISABLE

will also cause the flow meter to advance to the next Program step. If you select VOLUME for sampler pacing, the following will appear:

```
SAMPLER PACING
ENTER PACING VOLUME XX.XXXX CF
```

- Other units of measure may appear here. The range for pacing is max. flow divided by 100 (minimum) or 10,000 times max. flow (maximum.)

If Flowlink appears for sampler pacing, the operation of sampler pacing has been determined by choices made in Flowlink, Isco's proprietary data acquisition and storage software. Flowlink controls the flow meter remotely, via phone lines and a modem, or locally with a laptop computer and cable. In any event, if the sampler pacing definition is controlled by Flowlink, it can only be changed through Flowlink.

If you select CONDITIONAL for sampler pacing, the following will appear:

```
CONDITION
•(LEVEL)••(VELOCITY)••(FLOW RATE)••(RAINFALL)•
```

(DO), (pH), (TEMPERATURE), (YSI pH), (YSI DO), (YSI CONDUCTIVITY) and (YSI TEMP) may also appear. Note that all the conditions shown above are in parentheses. Which ones actually appear depends on your previous programming selections. At least one of these options will be available to you.

Pressing the **right arrow** key may be necessary to bring all items onto the display, provided they are available for use.

LEVEL will only appear if the flow meter is set up to measure level or flow.

RAINFALL, D.O., pH, and TEMPERATURE measurement require the appropriate sensor probe be used with the flow meter. Remember that only one parameter condition (D.O. or pH) can be measured by the flow meter at a time, unless you use the YSI 600 Sonde.

RAINFALL can appear if you have a rain gauge attached to the flow meter.

TEMPERATURE can be measured alone, or with either parameter.

D. O. and/or pH may not appear on the menu, depending on selections made in **step 1**. If you do not see the item you need, return to **step 1**, and recheck your programming. If you did not make the proper selections there, certain menu options will not appear here, as they would have been locked out.

The YSI 600 conditions of pH, DO, CONDUCTIVITY, and TEMPERATURE will only appear on the menu if you have turned them on in **steps 1 and 3**.

For any of these conditions, you can set the point at which change in the selected condition causes the flow meter to send a flow pulse to the sampler. The following menu will appear:

```
(Selected CONDITION)
• GREATER THAN • • LESS THAN • • RATE OF CHANGE •
```

If you select GREATER THAN, the flow meter will ask you to enter a maximum value for the selected condition, which if exceeded, will trigger the flow pulse.

If you select LESS THAN, the flow meter will ask you to enter a minimum value for the selected condition. If the condition falls below that value later, the flow meter will send a flow pulse to the sampler.

If you select RATE OF CHANGE, the flow meter will ask for two values: one for the condition, and the other for the time interval over which the change occurs.

After you have determined what condition will signal the sampler and under what circumstances, the following menu will appear:

```
SELECT OPERATOR
• DONE • • OR • • AND •
```

SELECT OPERATOR allows you to trigger the sampler from a single condition or from two conditions. Suppose you wanted to trigger the sampler from only one condition and that condition was LEVEL. You would select level as the condition, and then identify what change in LEVEL would be the trigger. Then you would select DONE for the SELECT OPERATOR step. Selection of DONE will advance the flow meter to the next program step.

However, suppose you wanted to select *two* conditions, *either* of which would trigger the sampler. In such a case you would select OR for the SELECT OPERATOR step. The menu will return to the one listing the conditions. This will let you define the second condition. Now the flow meter will trigger the sampler when *either* condition changes.

Finally, suppose you had a situation where you wanted changes in two conditions to occur before you signalled the sampler. In that case you would select AND for the SELECT OPERATOR step. Then you would define the second condition. Now the flow meter will signal the sampler only after *both* conditions have changed.

The next screen on the flow meter (after you have established the conditions for sampler pacing) will request the following. (Entering 0 sends no pulses.)

```
CONDITION TRUE PACING INTERVAL
PACE EVERY X MINUTES
```

This option allows you to send flow pulses periodically to the sampler during the time the conditions you established for sampler pacing are being met.

Then:

CONDITION FALSE PACING INTERVAL PACE EVERY X MINUTES

This option allows you to send flow pulses periodically to the sampler during the time the conditions you established for sampler pacing are not being met. Again, entering **0** sends no pulses.

2.4.9 Step 6 - Sampler Enable

The operation of **step 6, Sampler Enable** is similar to **step 5, Sampler Pacing**. The menus and options are similar. The difference is that where sampler pacing only causes the flow meter to send a momentary signal (flow pulse) to the sampler, sampler enabling actually controls an inhibit line to the sampler that can keep the sampler from running its program. Sampler enabling is useful where the sampler needs to remain idle for long periods of time, such as **storm water runoff** applications. When you select or advance to **step 6**, the following display will appear:

SAMPLER ENABLE MODE • DISABLE •• ENABLE •• CONDITIONAL •• (STORM) •
--

(Flowlink) may also appear. The Flowlink menu option will not appear unless Flowlink software is installed.

DISABLE means that the sampler will be permanently inhibited by the flow meter. This condition will remain until you change it in this program step, or if you are using Flowlink, until it is overridden by a command from Flowlink. Select the DISABLE option with care; it will make the sampler appear to be inoperative, and that could easily be misinterpreted as an equipment failure.

ENABLE means that the sampler is permanently enabled, free to run its own program without any control from the flow meter. This condition will remain until you change this menu option, or until it is overridden by a command from Flowlink.

The STORM option will not appear unless you turned on rainfall measurement in **step 1**. STORM selection is what you use when you want to monitor storm water runoff.

STORM enabling is really a combination of conditions. First, enter a value for LEVEL in the flow stream. Second, enter a value for RAINFALL. Third, enter an amount of time over which the rainfall occurs. Finally, you enter a time since the last rainfall. You must have an Isco **674 Rain Gauge**, or approved equal to measure rainfall. The following menus are the STORM sequence:

LEVEL GREATER THAN X.XXX FT (or other units of measure)
--

Then:

RAINFALL AMOUNT X.XX INCHES (or other units of measure)
--

Then:

RAINFALL TIME PERIOD • 15 MIN •• 30 MIN •• 1 HR •• 2 HR •• 4 HR •
--

If you press the **right arrow** key several times, the following times will appear:

RAINFALL TIME PERIOD • 6 HR •• 8 HR •• 12 HR •• 24 HR •• 48 HR •• 72 HR •
--

The intervals above are the periods of time over which the rainfall occurs. The amount of rain entered in the previous step and detected by the rain gauge must fall during the time interval chosen from this menu before the flow meter recognizes the event as a storm. The next menu defines the interval that must pass **between** storm events.

TIME SINCE LAST RAINFALL DAYS: X (allowable entry of 1-7)
--

If you select CONDITION from SAMPLER ENABLE, the following will appear:

CONDITION • (LEVEL) •• (FLOW RATE) •• (VELOCITY) •• (D.O.) •• (pH) •

(TEMPERATURE), (RAINFALL), (YSI pH), (YSI DO), (YSI CONDUCTIVITY) and (YSI TEMP) may also appear.

The above conditions are all shown in parentheses, because they may not be available to you by the time you reach this menu. The menus that do appear will depend on programming selections made earlier in the program. At least one of the conditions will be available to you. Operation of the conditions is the same as for **step 5 Sampler Pacing**. If you select LEVEL from CONDITION the following will appear:

LEVEL • GREATER THAN •• LESS THAN •• RATE OF CHANGE •
--

After you select one of these options, the flow meter will request that you enter a value, for example if you selected GREATER THAN:

LEVEL GREATER THAN X.XX FEET (or other units of measure)

Enter a maximum value for the selected condition, which if exceeded, will enable the sampler.

If you select LESS THAN, the flow meter will ask you to enter a minimum value for the selected condition. If the condition falls below that value later, the flow meter will enable the sampler.

If you select RATE OF CHANGE, the flow meter will ask you to enter two values, one for the condition, and the other for a period of time over which the change occurs.

After you have determined what condition will signal the sampler and under what circumstances, the following menu will appear:

```
SELECT OPERATOR
• DONE •• OR •• AND •
```

This step allows you to trigger the sampler from a single condition or from two conditions. Suppose you wanted to trigger the sampler from only one condition and that condition was level. You would select level as the condition, and then identify what change in level would be the trigger. Then you would select DONE for the SELECT OPERATOR step. Selection of DONE will advance the flow meter to the next program step. Selection of OR or AND will allow you to select another condition, and then determine whether both conditions are necessary for enabling (AND) or whether either condition will enable the sampler (OR). If you select FLOW RATE:

```
FLOW RATE
• GREATER THAN •• LESS THAN •• RATE OF CHANGE •
```

You would select one of these options, and then enter a value, as for LEVEL, previously.

The rest of the menus will appear the same as they did for LEVEL and FLOW RATE. D. O., pH, TEMPERATURE, and RAINFALL all require activation in **step 1** and use of the appropriate sensor. Only one parameter condition (pH, D. O.) can be measured by the flow meter at a time. pH and D. O. will not appear on the display at the same time.

It is possible to program the sampler enable option so that it operates in two different modes, **latching** and **non-latching**.

To explain this, in the **non-latching** mode the sampler will be enabled only as long as the condition that caused the enabling remains outside of “normal.” If the enabling condition returns to “normal,” the sampler enable will turn off until the next time the condition goes outside of “normal.”

In the **latching** mode, the sampler will be enabled the first time the condition goes outside of normal and the sampler *will stay enabled regardless of any later changes to the enabling condition*. If this is the case, the following menu will allow you to reset the sampler enable feature. Note that this menu will not appear unless the condition necessary to enable the sampler has been met and the sampler is currently enabled.

```
WHEN ENABLE CONDITION IS NO LONGER MET
• DISABLE SAMPLER •• KEEP ENABLED •
```

Or:

```
ENABLE CURRENTLY LATCHED, RESET?
• NO •• YES •
```

Select YES to reset the sampler enable feature; select NO to leave the sampler enabled.

PRINTER ON/OFF WITH ENABLE
• YES •• NO •

This selection allows you to turn the flow meter's internal printer on or off when the sampler is enabled from the flow meter. This allows you to conserve battery power and only print a chart when the sampler is enabled. This feature is useful for monitoring storm water runoff.

2.4.10 Step 7 - Alarm Dialout Mode

This step lets you signal an alarm to a remote location from the flow meter. The conditions that can cause an alarm are the same as described previously for sampler enabling.

Note

You must have the optional internal modem installed and connected to a telephone network to make use of this feature. **This menu will not even appear if you do not have a modem.** The flow meter will automatically advance to the next step.

More information about the modem can be found in Section 4. If you have the modem installed and select **step 7**, the following will appear:

ALARM DIAL OUT
• DISABLE •• CONDITIONAL •• STORM •• FLOWLINK •

If you select DISABLE, this option will be inactivated until you change the selection later. The program will advance to the next step. If you select STORM, the flow meter will request definitions similar to those for STORM in sampler enable. The following will appear:

LEVEL
GREATER THAN X.XXX FT (*or other units of measure*)

Then:

RAINFALL AMOUNT
X.XX INCHES (*or other units of measure*)

Then:

RAINFALL TIME PERIOD
• 15 MIN •• 30 MIN •• 1 HR •• 2 HR •• 4 HR •

If you press the **right arrow** key several times, the following times will appear:

RAINFALL TIME PERIOD
• 6 HR •• 8 HR •• 12 HR •• 24 HR •• 48 HR •• 72 HR •

The intervals above are the periods of time over which the rainfall occurs. The amount of rain entered in the previous step and detected by the rain gauge must fall during the time interval chosen from this menu before the flow meter recognizes the event as a storm. The next menu defines the interval that must pass **between** storm events.

TIME SINCE LAST RAINFALL DAYS: X (allowable entry of 1-7)
--

If you select CONDITIONAL for alarm dialout, the following will appear:

CONDITION • (LEVEL) •• (VELOCITY) •• (FLOW RATE) •• (D. O.) •• (pH) •
--

(TEMPERATURE), (RAINFALL), (YSI pH), (YSI DO), (YSI CONDUCTIVITY), and (YSI TEMP) may also appear. As mentioned previously, some of these menu options may not appear depending on selections you made earlier in the program. At least one of the options will be available to you. As mentioned for other program steps, some of these menu options may not appear depending on the flow meter you have and choices you made earlier in the program. D. O., pH, TEMPERATURE, and RAINFALL all require activation in **step 1** and connection of the appropriate sensor to the flow meter. D. O. and pH will never appear together, as only one can be used at a time. When you have selected the condition you want, the display will advance to the following:

CONDITION • GREATER THAN •• LESS THAN •• RATE OF CHANGE •
--

For these conditions, you enter an amount which if exceeded (GREATER THAN), or if dropped below (LESS THAN), or if changed too quickly (RATE OF CHANGE), will activate the alarm dialout. For RATE OF CHANGE, you enter two values: **amount** and **time over which change occurs**. Then the display will advance to the following:

SELECT OPERATOR • DONE •• OR •• AND •
--

As described for sampler enabling previously, this step allows you to combine conditions to produce an alarm dialout signal. Select DONE if you don't need more than one condition to trigger the alarm.

If you want *either* of two conditions to trigger an alarm, select OR.

If you want *both* of two conditions to be met before signalling an alarm, select AND. Selection of DONE will advance you to the next display menu. Selection of OR or AND will return you to the CONDITION menu to select the other condition.

The flow meter will then request that you enter the telephone numbers for the remote alarms. There are five possible telephone numbers, in decreasing order of importance. You can enter as many as eighteen digits for each phone, so the remote targets need not necessarily be local.

```
ALARM DIALOUT NUMBERS
• DONE •• NUM 1 •• NUM 2 •• NUM 3 •• NUM 4 •• NUM 5 •
```

If you select DONE, the flow meter will advance to the next step. If you select one of the NUM entries, such as NUM 1, the following will appear:

```
FIRST PHONE NUMBER
XXXXXXXXXXXXXXXXXXXX
```

You can enter the phone numbers as straight seven or ten-digit numbers, or you can use the +/- key to enter a dash. You can use the (.) (decimal) key to enter a (,) (comma). If you want to signal more than one remote number at a time, the numbers are arranged in decreasing priority. NUM 1 carries the highest priority, followed by NUM 2 and so on. After you have entered the numbers, the flow meter will request:

```
DELAY BETWEEN DIALOUTS
XX MINUTES
```

This is the time delay between calling the first number and calling the second, etc. This option gives you time to respond to an alarm before the flow meter dials the next number. Select a value between 1 and 99 minutes. Then the display will advance to the following:

```
CALLBACK TO DISABLE ALARM
• YES •• NO •
```

Select YES if you want to be able to acknowledge the alarm condition in the flow meter by calling back. No message is spoken on this callback. When the flow meter's modem detects the ring, it will answer and automatically reset the alarm. If there is no one available to answer an alarm, you can have the flow meter dial a paging service and then someone with a pager can call back to acknowledge the alarm. To acknowledge an alarm from a touch tone phone; wait for the spoken message to complete; then press *-X-X-X. The X-X-X is the three digits of the site ID number.

2.4.11 Step 8 - Printer

This step sets up the operation of the flow meter's internal printer. This printer also functions as a plotter. The printer/plotter is capable of printing alphanumeric information (words and numbers), and at the same time, plotting linear data like flow, level, pH, etc. The unit can print as many as three different data lines at the same time it regularly records other printed information routinely supplied from the flow meter.

Program selections made in this step will determine the appearance of the printer/printer's chart. The first menu will request the speed of the chart.

ENTER PRINTER SPEED
• OFF •• 1/2"/HR •• 1"/HR •• 2"/HR •• 4"/HR •

If you select OFF, the printer will be disabled. No data will be printed. The flow meter will, however, still print reports if you activate that in **step 9**. The choice made from the other speeds depends on the amount of data you need to record. If you are recording from a stable situation and are using only one data line, and you want to achieve maximum life for the paper roll, select a lower speed for chart advance. If there is a great deal of activity in your stream, and you need to use all three data lines, selection of a faster chart speed will produce a chart more easily read and interpreted. After you select the printer speed, the flow meter will ask you to define what you want depicted by LINE A. (The printer can print as many as three separate lines at the same time.) The following will appear:

INPUT FOR PRINTER LINE A
• (LEVEL) •• (VELOCITY) •• (FLOW RATE) •• (pH) •• OFF •

(TEMPERATURE), (YSI pH), (YSI D.O.), (YSI CONDUCTIVITY), and (YSI TEMP) can also appear. Remember that menus in parentheses may not appear due to previous program selections. Either pH or D. O. may appear, but not both. The various YSI options will only appear if you enabled the YSI 600 in **step 1**. You must have the appropriate probes to sense these conditions. Select OFF if you do not need this line. If you select pH, D. O., TEMPERATURE, or any of the YSI options, the flow meter will request that you set limits that will serve as the bottom of the chart and the chart full-scale.

PRINTER LINE A BOTTOM SCALE
X.XX pH (or other condition, as selected previously)

You would enter here the lowest pH value you expect to see in your flow stream:

PRINTER LINE A FULL SCALE
X.XX pH (or other condition, as selected previously)

Enter here the highest pH value you expect to see in your flow stream. Selection depends on the range you would normally see. If your stream varies from 6 to 8 pH units, you would not want to enter 0 and 14 as limits. Chart resolution would be poor. You could enter 5 and 9 pH and still have good resolution if there were sharp deviations because of the availability of over-ranges. Selection of OFF from the INPUT FOR PRINTER LINE menu will leave this line blank. Selection of conditions other than pH, D.O., TEMPERATURE, or YSI-functions will result in a request

that you enter the full-scale value for the condition being plotted. For example, if you selected LEVEL as a condition, the following would appear:

```
PRINTER LINE A FULL SCALE
X.XXXX FEET (or other units of measure, as selected)
```

The flow meter automatically goes into over-range if the data goes higher than the full-scale value you have selected. You can easily recognize over-range operation by the plotted line running off the right side of the chart and then immediately reappearing on the left side of the chart. Because of the over-range feature, you can set a full-scale value that gives you good resolution on the chart. At the same time, the automatic over-range will prevent the loss of recorded data if the plotted line rises past the full-scale point. For the other conditions, the full-scale units will be appropriate for what is being measured (D. O., pH, temperature, etc.) The flow meter is capable of multiple over-ranges.

```
INPUT FOR PRINTER LINE B
•(LEVEL)••(FLOW RATE)••(VELOCITY)••(pH)••OFF•
```

(TEMPERATURE), (YSI pH), (YSI D.O.), (YSI SALINITY), and (YSI TEMP) may also appear. Again, as for line A, you can select another condition to plot on the chart. The flow meter will again request a full-scale value. The full-scale value can be different from that of line A.

```
INPUT FOR PRINTER LINE C
•NONE••(LEVEL)••(FLOW RATE)••(pH)••(D. O.)•
```

(TEMPERATURE), (YSI pH), (YSI D.O.), (YSI SALINITY), and (YSI TEMP) may also appear. For line C, you can select yet another condition to plot on the chart. The flow meter will again request entry of a full-scale, or bottom and full-scale value.

```
PLOT RAINFALL ON CHART?
•NO••YES•
```

You must have an Isco Rain Gauge or equivalent connected to the flow meter to measure rainfall. Output is recorded in either inches or millimeters. There is only one over-range for rainfall.

2.4.12 Step 9 - Reports/History

Go to **step 9** and the following display will appear:

```
REPORT GENERATOR A
•ON••OFF••(PRINT)•
```

This step lets you set up the flow meter to print periodic reports. The typical report contains such information as the period of time covered in the report, maximum and minimum levels, and when they occurred. You can define two different reports in this step. For example, this is used to provide weekly and monthly reports. You can choose the content of the reports by working through the menus in **step 1**.

If you select OFF, the program will advance to the next step, and there will be no report A generated. If you select YES, the following will appear:

```
REPORT A DURATION TO BE IN
• HOURS •• DAYS •• MONTHS •
```

After you select the units of time, this will appear.

```
ENTER REPORT A DURATION
XX HOURS
```

DAYS or MONTHS could also appear, depending on what you selected for the previous step. The time selected becomes the time interval that will be covered in the report. Then the flow meter will ask you when you want the first report printed:

```
PRINT REPORT A AT
YR: XXXX MONTH: XX DAY: XX HR: XX MIN: XX
```

Then:

```
REPORT GENERATOR B
• ON •• OFF •• (PRINT) •
```

The second report generator lets you program the flow meter to print two independent reports at different intervals, for example. This is useful for those who need both a weekly and a monthly summary of activity on the flow meter. If you select OFF for this step, the program will advance to the next step, and there will be no report B generated. If you select YES, the following will appear:

```
REPORT B DURATION TO BE IN
• HOURS •• DAYS •• MONTHS •
```

Select the appropriate interval for this second report. After you select the units of time the following will appear:

```
ENTER REPORT B DURATION
XX HOURS
```

DAYS or MONTHS could also appear depending on what you selected for the previous step. The time selected becomes the time interval that will be covered in the report. Then the flow meter will ask you when you want the first report printed:

```
PRINT REPORT A AT
YR: XXXX MONTH: XX DAY: XX HR: XX MIN: XX
```

After you have entered the desired date for the first report, the program will advance to the following:

```
PRINT FLOW METER HISTORY
• YES •• NO •
```

The final step on the flow meter is FLOW METER HISTORY. This step presents a record of the programming activity on the flow meter that you can have printed on the printer. The flow meter keeps a record of certain programming changes and prints them out. If you select YES, the following will appear:

PRINT FLOW METER HISTORY • PRINT SINCE LAST • • PRINT ALL •
--

If you select PRINT SINCE LAST, the flow meter will only print the changes that have occurred since the last print request. If there were no changes, there will be no print. If you select PRINT ALL, the flow meter will print all the changes it has in memory, as far back as 50 entries.

If you selected NO from PRINT FLOW METER HISTORY, the flow meter will advance to CLEAR HISTORY - YES, NO.

If you select NO again, the flow meter will exit programming and return to the normal display. If you clear the memory, previous programming changes will be erased, but the flow meter will again begin keeping track of changes the next time you change the program.

2.4.13 Flow Meter History Contents

D. O. ADJUSTED
pH ADJUSTED
LEVEL ADJUSTED
FLOW CONVERSION CHANGED
PLOTTER SPEED CHANGED
PLOTTER TURNED ON
PLOTTER TURNED OFF
TIME CHANGE FROM
TIME CHANGE TO
REPORT A CHANGED
REPORT B CHANGED
REPORT A TURNED ON
REPORT B TURNED ON
REPORT A TURNED OFF
REPORT B TURNED OFF
TOTALIZER RESET
INTERROGATED
SAMPLER ENABLED
SAMPLER DISABLED
ALARM ACKED BY #X
ALARM NOT ACKNOWLEDGED
YSI pH ADJUSTED
YSI D.O. ADJUSTED
YSI CONDUCTIVITY ADJUSTED

4250 Flow Meter

Section 3 Installation

This section of the manual contains information on installing the 4250 Flow Meter. Included are sections on power sources, mounting methods, interconnection wiring, installation of the AV sensor and setup procedure for the unit.

3.1 Preparation for Use

The flow meter is shipped with a roll of paper installed and a standard program in the system memory, called the **default** program. This program exists to test the flow meter at the factory, and also because the computer must always have something programmed. You will usually program the flow meter differently for your installation.

You should familiarize yourself with the programming procedure and practice working through the program on the flow meter to become comfortable with programming. You can program the unit in the shop rather than at the job site, with the exception of the level adjustment, if you want. This will minimize the possibility of dirt and moisture getting inside the flow meter at the installation.

3.1.1 Installing the Desiccant Canister

If the unit is new, at this time you can install the desiccant canister. It is provided in the accessory package and looks like a small, flat can with little holes in it. Open the flow meter case lid. Note the small clamp that resembles a bottle cap opener located near the bottom right-hand corner of the case lid. Install the desiccant canister by pressing it under this bracket, with its viewing window lined up with the circular hole in the bracket.

Make sure the clamp is fully engaged over the canister. The particles inside the desiccant window should be blue. If the particles are pink, the desiccant is saturated and you need to regenerate it before using it. If the unit has been in use and has been returned for reprogramming, clean it and inspect it as outlined in Section 5 of this manual. You can also install the external desiccant cartridge, which provides pressure equalization for the AV sensor pressure transducer.

3.1.2 Installing the External Desiccant Cartridge

Snap the external desiccant cartridge into the clamps mounted on the top of the cabinet. Then attach the silicone tubing between the top of the desiccant cartridge and the black plastic elbow fitting mounted on the side of the case near the top.

This desiccator keeps moisture out of the AV sensor's reference port. This port connects to a tiny tube that goes through the case and the sensor cable all the way to the transducer. Like the case desiccant canister, the external desiccant cartridge should be colored blue. If it is violet or pinkish, you need to regenerate it.

You will need to remove the particles from the cartridge for regeneration; you cannot regenerate the cartridge like the case desiccant canister. The cartridge is plastic and will melt. See Section 5 for details on regenerating the desiccant cartridge.

 **CAUTION**

Be sure to remove the red plastic cap from the desiccator cartridge when you install the flow meter. If you do not, the AV sensor will be unable to reference to atmospheric pressure, and inaccurate level measurements will result.

Many flow meters are installed in damp environments in atmospheres containing corrosive fumes. These fumes can form weak acids with moisture. Keeping the desiccators active and the door closed will prevent these fumes from damaging the flow meter. Keep the lid closed and latched except when you are installing the unit or changing the program.

Do **not** operate the flow meter with the door open or the desiccators saturated. If you leave the door open, moisture in the air will quickly saturate the desiccant. Dust may damage the printer mechanism. Water or dirt drawn into the reference port can block the tubing, preventing the pressure transducer from sensing atmospheric pressure.

Symptoms of a clogged reference port on the AV sensor are varied. Noticeable drift in measured level when you know the level is essentially constant, or an oscillation in the level corresponding to changes in barometric pressure are two indicators of clogging in the reference port tube.

If dirt and/or moisture block the reference tube between the desiccant cartridge and the AV sensor connector on the flow meter, you may be able to clear the blockage from the tube by applying compressed air. Likewise, if the blockage is inside an *extension cable* for the AV sensor, you can try to clear it with air. In these cases, both ends of the tube are accessible.

However, if the blockage is inside the AV sensor's cable, the sensor may be ruined. The cable is sealed where it enters the AV sensor and the sensor itself is a sealed unit. Consequently, you cannot push air through the tube. Applying pressure to the connector will only drive the water further into the line, and may destroy the transducer inside the probe. If you suspect blockage in the AV sensor's reference tube, return the probe to Teledyne Isco. The repair department may be able to vacuum the water or blockage from the line; however, water may cause permanent internal damage, and not all blockages are removable.

You can avoid this problem completely by preventing moisture from entering the reference tube in the first place. Maintain the desiccators. Inspect them frequently and regenerate them when necessary.

3.1.3 Opening the Case To access the flow meter controls and plotter, you must open the case. Unlatch the two catches on the right side of the case and pull open the lid. You will need to open the case whenever you change the plotter chart, or change the programming with the keypad. You can read the display through the window, so you can take periodic readings without opening the case. Again, do not allow the flow meter to operate routinely with the door open.

3.2 Connection to a Power Source The 4250 requires a 12-volt, direct current (12 VDC) power input. This power may come from various sources:

- Companion Isco sampler
- Isco Nickel-Cadmium Battery
- Isco Lead-Acid Battery
- Isco AC Power Supply
- External 12 VDC battery, such as a deep-cycle marine or RV type

Detailed information on power sources is provided in the *Power Products Guide* provided with this manual. The procedures for connecting various power sources to the flow meter are discussed in the following sections.

3.2.1 Low Power Indication When power to the flow meter falls too low for the unit to operate properly, the message POWER LOST - LOW BATTERY will appear on the top line of the display. When power is lost or falls below operating limits, the flow meter will stop measuring level, the display will go blank, and the internal printer will not be able to print. However, the internal battery-backed RAM will retain your program selections and stored data in memory, if there is any. (Note that you must be using FLOWLINK software for any data to accumulate in memory.)

3.2.2 Isco Sampler If you combine a 4250 Flow Meter with an Isco Wastewater Sampler in a flow-paced sampling system, you can power the flow meter from the sampler's power supply. Connect the flow meter to the sampler with the Isco flow meter-to-sampler cable. This cable attaches to the **Sampler** connector on the flow meter and the **Flow Meter** connector on the sampler.

The flow meter will then receive power from the sampler. Keep in mind that under certain conditions, such as a fast setting on the chart speed, the flow meter will draw a significant amount of power from the sampler's battery. In such cases it is better for the flow meter to have its own battery.

Note

Do **not** attempt to run a sampler from a power source installed on the flow meter. While a flow meter will operate satisfactorily with a power source installed on a sampler, *the reverse is not true*. The sampler's pump draws heavy current, particularly on start-up. The flow meter-to-sampler connect cable cannot carry such currents. If you are using a single power source for a flow meter-sampler combination, **always** install the power supply on the sampler.

3.2.3 Isco Nickel-Cadmium Battery

Teledyne Isco offers a 4 ampere-hour 12-volt rechargeable nickel-cadmium battery pack to power the flow meter. Teledyne Isco packages this battery specifically for use with Isco flow meters and samplers. Refer to the *Power Products Guide* accompanying this manual for detailed information about this battery and the procedure for charging it.

Attaching the Nickel-Cadmium Battery – Install the battery on the top of the flow meter case, and attach its connector to the 12 VDC connector on the side of the flow meter. Place the battery with its cable pointing toward the right side of the cabinet. Secure the battery by stretching the two rubber draw catches on top of the flow meter until they slip over the two metal “U” brackets on the ends of the battery case. Then screw the battery connector into the top mating connector on the right side of the flow meter case.



Figure 3-1 Battery Installed on Flow Meter

3.2.4 Isco Lead-Acid Battery

Teledyne Isco also offers a 6.5 ampere-hour 12-volt rechargeable lead-acid battery to power the flow meter. This battery is similar in size to the nickel-cadmium battery, except somewhat larger, reflecting its 50% greater capacity. Operation and maintenance of these batteries differs somewhat from that of the nickel-cadmium battery.

- Fewer charge-discharge cycles are possible, and a single deep discharge can ruin a battery, if it discharges all the way to cell-reversal.
- There is a linear voltage decrease as the battery discharges, while nickel-cadmium batteries show essentially the same voltage throughout discharge.
- Failure to recharge promptly and low temperature operation can also ruin the battery. Proper operation and maintenance are necessary for normal service life.

For detailed information on these batteries, refer to the *Power Products Guide*. Please read that manual if you intend to use lead-acid batteries on your flow meter.

Attaching the Isco Lead-Acid Battery – The lead-acid battery connects the same way as the nickel-cadmium battery. Place the battery on top of the case and secure it with the rubber draw catches. Attach the connector to the flow meter. If your flow meter is permanently installed, you may need to allow extra clearance above the flow meter for the slightly greater height of this battery.

 **CAUTION**

Do **not** test either lead-acid or nickel-cadmium batteries for the condition of charge by “sparking” the output (shorting the terminals together with a wire, screwdriver, or other tool).

3.2.5 AC Power Supplies

Teledyne Isco also offers two different AC power supplies, the **High Capacity Power Pack** and the **Battery-Backed Power Pack**, to power the flow meter. These power supplies are designed for operation from 120 Volts AC, 50/60 Hz commercial power sources. Alternate versions, designed for operation from 240 Volts AC, 50/60 Hz are also available and are intended primarily for export. Both are supplied with a line cord for convenient attachment to the AC power source.

They are both capable of operating the flow meter. The Battery-Backed Power Pack provides 12 VDC at 5 Amperes, and is backed up by a 1.2 Ampere-hour nickel-cadmium battery. This is built in a package the same size as the standard power supply, and is intended for use where short-term power interruptions are frequent but unacceptable for flow meter operation.

 **Note**

The battery in the Battery-Backed Power Supply is of limited capacity. It is intended for short-term backup duty only. With one-fourth of the capacity of a standard battery, it can only power the flow meter for a limited period of time (approximately one day).

Attaching the Power Supply – Mount the power supply on top of the flow meter cabinet the same as described for the batteries. Secure the power supply with the two rubber draw catches pulled over the brackets on the ends of the power supply. Attach the short cable with the smaller connector to the top connector on the right side of the flow meter case. Connect the longer cord with the plug on it to an **unswitched** AC outlet. Refer to *Power Products Guide* for details about charging batteries with the power pack.



Figure 3-2 Power Pack Installed on Flow Meter

3.2.6 External 12 Volt Direct Current Source

You can also power the flow meter from an external 12 VDC source, such as an automotive, motorcycle, or marine battery. Many people have found that a deep-cycle marine/RV battery is particularly well-suited to this application. However, you will have to mount batteries of this type externally, as they are too large to fit on top of the flow meter. Teledyne Isco offers a special optional connect cable to power the flow meter from a separate battery. Mount the battery securely, *in an upright position*, so it will not inadvertently tip over, or be at risk of having its cable pulled off.

CAUTION

Be sure of proper polarity before attaching clips to the battery. **Never** attach the flow meter to a source of unknown polarity or voltage. If in doubt, check with a reliable DC voltmeter. **Never** attach the flow meter directly to an AC power source under any circumstances. Charge batteries only with compatible equipment, in accordance with manufacturer's instructions.

3.3 Flow Meter Mounting and Installation

The 4250 Flow Meter is a portable device; you may install it permanently or temporarily. You can suspend the flow meter in temporary installations, such as sewers, or mount it permanently in other installations, such as treatment plants, at your option.

CAUTION

Before any flow meter is installed, the proper safety precautions must be taken. The discussions of safety procedures provided in the back of this manual are only general guidelines. Each situation in which you install a flow meter varies. You must take into account the individual circumstances of your installation. Additional safety considerations, other than those discussed, may be required.

3.3.1 Carrying Handle

To help carry or suspend the flow meter, a handle is provided in the accessory package. To use the handle, clip the hooks at both ends onto the two metal brackets at the top of both side of the case.

3.3.2 Location of the Flow Meter

Because the flow meter uses an AV sensor for flow measurement, you do not have to install it directly above the measurement point, or even particularly close to the flow stream. You can install the flow meter in a convenient, protected location and route the AV sensor cable to the place where the level sensor is mounted. For example, you can install the flow meter above ground for protection and easy accessibility, and then you only need to enter the manhole for sensor installation and calibration (and occasionally thereafter for maintenance and inspection). You will need to mount the unit within 25 feet (7.6 m), (or 50 feet [15.3 m] with the 30 foot sensor) if you connect the sensor directly to the flow meter.

WARNING

The 4250 Flow Meter has not been approved for use in hazardous locations as defined by the National Electrical Code.

You can extend the distance to 50 feet (15.3 m) if you use the optional **25-Foot Extension Cable**. Connecting two extensions together lets you increase the distance to 75 feet (22.8 m). Do not exceed 75 feet with the extensions; this will slow the response of the sensor to level and atmospheric changes.

For distances from 75 to 1,000 feet, (304.8 m) use the optional **Quick-Disconnect Box**. Distances greater than 1,000 feet are not recommended. Details on the extension cable and Quick-Disconnect Box can be found in Section 4.

3.3.3 Mounting the 4250

The 4250 does not have any special requirements for mounting. You can locate it on any relatively flat surface either horizontally, supported by the two mounting pads and the stainless steel mounting bracket, or vertically, supported by the two plastic rails on the bottom of the case.

You can also panel-mount the flow meter, using the mounting bracket on the top rear of the case, or suspend it from a ladder rung using the optional suspension bracket. To use the bracket, the carrying handle should first be installed on the flow meter as described above. Then slip the handle through the suspension bracket.



Figure 3-3 4250 Suspended by Handle (handles may vary)

3.3.4 Vent Hose to Desiccant Cartridge

If you suspend the flow meter above the flow stream and there is any possibility of accidental submersion, attach several feet of vinyl tubing to the open vent on the end of the external desiccant cartridge. You should route this tubing to a place higher than the maximum possible level of the flow stream. This will prevent any water from entering the vent tube of the AV sensor in case of accidental submersion of the flow meter. Vinyl tubing can be purchased locally or from Teledyne Isco.

If you use the Quick-Disconnect Box to extend the distance between the flow meter and the sensor, attach the vinyl tubing to the desiccator cartridge vent on the Quick-Disconnect Box rather than the vent on the flow meter. (Presumably the flow meter is mounted safely away from the flow stream if you are using the Quick-Disconnect Box.) If you cannot mount the Quick-Disconnect Box far enough above the flow stream to ensure against accidental submersion when the flow stream is high, you should protect the desiccator and the reference port by venting them with vinyl tubing to a point the water cannot possibly reach.

Remember that water or other blockage inside the sensor's vent tube can ruin the sensor. It is even more important to protect the Quick-Disconnect Box than the flow meter, because the AV sensor will be directly attached to the Quick-Disconnect Box. When connecting the sensor to the flow meter, you may use an extension cable, which would offer some protection to the sensor.

3.4 Quick-Disconnect Box

You can install the flow meter as far as 1,000 feet from the AV sensor if you use the Quick-Disconnect Box. Otherwise, you must locate the flow meter within 75 feet of the 10 foot AV sensor, (100 feet for the 30 foot AV sensor), as this is the maximum length of cable available to connect the AV sensor to the flow meter (25 or 50 feet supplied with either AV sensor plus 50 feet maximum with two of the AV sensor extension cables.) Do not try to add more extension cords. If you need greater lengths, use the Quick-Disconnect Box.



Figure 3-4 Quick-Disconnect Box for the Area Velocity Sensor

To use the Quick-Disconnect box, you will need a cable of the correct length with an M/S connector to plug into the flow meter. Teledyne Isco will build the cable with the proper connector on one end and stripped wires on the other end as a special order. You should power the flow meter from AC if you must use the Quick-Disconnect Box, especially if you need to run the full 1,000 feet.

You can install the cable in conduit and connect the conduit to the Quick-Disconnect Box or you can run the cable in the open to the Quick-Disconnect Box and attach it with a waterproof compression bushing (available from Teledyne Isco). If you use conduit, use a liquid-tight fitting and a washer at the Quick-Disconnect Box.

Wire Color	Terminal Number
Red	1
Green	2
White	3
Black	4
Orange-White	5
Orange	6
Blue	7
Blue-White	8

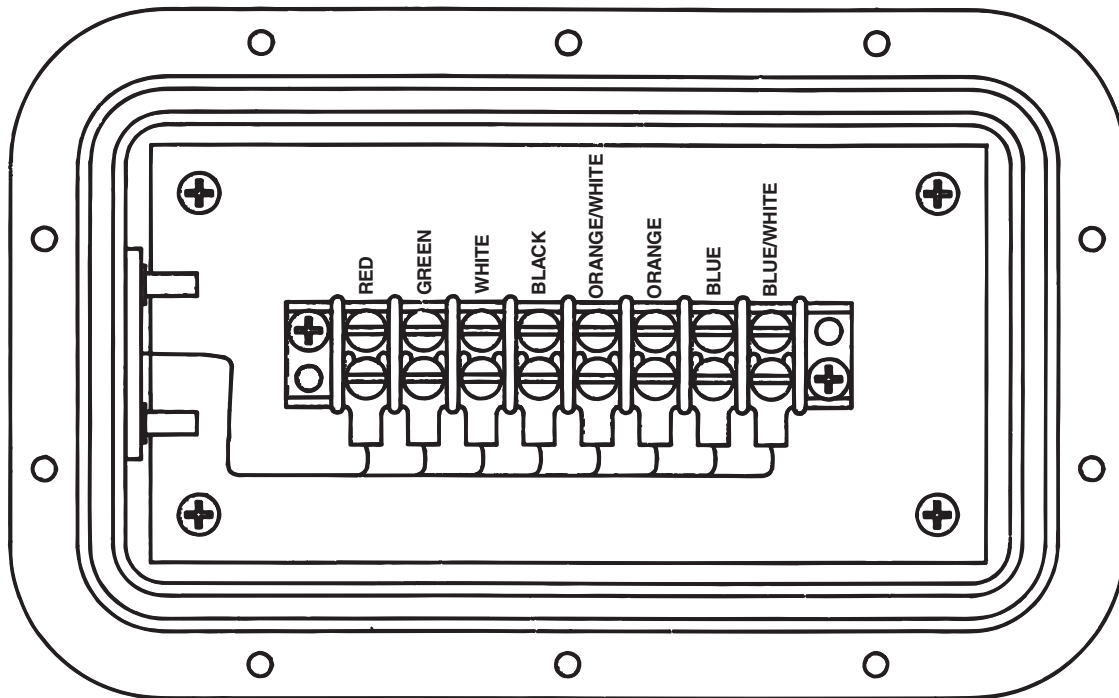

Figure 3-5 Cable Connections in the Quick-Disconnect Box

The wire colors shown are for the Teledyne Isco-supplied custom cable. You must use the Isco cable because the connector at the flow meter end of the cable is special and not available elsewhere. When you wire the cable inside the Quick-Disconnect Box, attach each wire to the terminal that has the **same color** wire soldered to it. Mount the Quick-Disconnect Box with screws through the holes in the stainless steel backplate. The connector on the AV sensor cable connects to the mating connector on the side of the Quick-Disconnect Box.

If you use the cable without conduit, you must install a compression bushing on the cable to make a water-tight connection. A picture of the compression bushing is on the next page. If you run the wiring inside conduit, liquid-tight fittings are needed. To minimize the effects of corrosion, we suggest the use of non-metallic conduit, if permissible.

The desiccant cartridge on the bottom of the Quick-Disconnect Box provides the atmospheric reference to the sensor's pressure transducer. If there is any chance of submersion of the Quick-Disconnect Box, attach vinyl tubing to the desiccant cartridge and route it to a place well above the maximum expected liquid level. When you have completed the wiring inside the box, replace the cover and tighten the screws that hold the cover securely to prevent the possibility of any moisture entering the case.

3.5 Extension Cables

The 10-foot range and low profile AV sensors are provided with 25 feet of cable. The 30-foot range AV sensor is provided with 50 feet of cable. If these lengths are insufficient, it is possible to connect an extension cable between the flow meter and the AV sensor. Teledyne Isco provides a 25-foot extension cable for either sensor.

 **CAUTION**

The AV sensor extension cables and the AV sensor cable **cannot** be cut for any reason, or they will be ruined. The connectors are factory-sealed and neither the cable nor the vent tube inside can be satisfactorily spliced in the field.

Teledyne Isco does not recommend connecting more than two extension cables together to exceed the 75-foot limit (100 ft. for the 30 ft. sensor). Increasing the length of the vent tube beyond 75 feet slows the response of the pressure transducer, and this may cause measurement errors. For greater distances use the Quick-Disconnect Box and a custom-built cable.

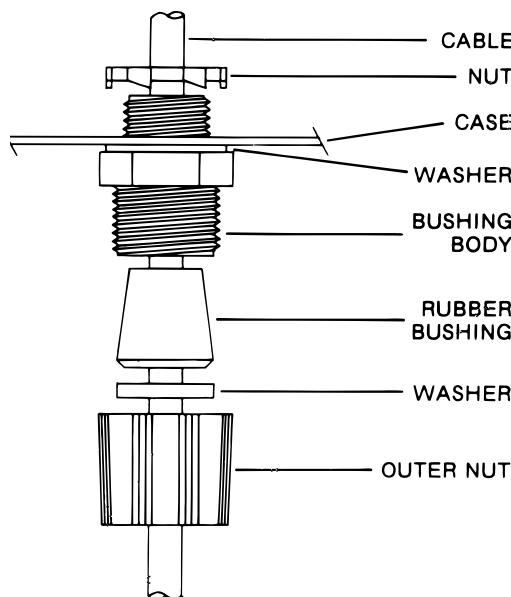

Figure 3-6 Assembling a Compression Bushing

The AV sensor uses a differential pressure transducer and two ultrasonic transducers. The cable connecting the AV sensor to the flow meter contains a small tube that references the pressure transducer to atmospheric pressure. This allows a true differential pressure measurement unaffected by changes in barometric pressure. This tube is vented through the connector into the cabinet of the 4250. From there, it is vented to the atmosphere through a desiccant cartridge mounted on the side of either the flow meter or the Quick-Disconnect Box.

3.6 Area Velocity Sensor Installation

Before installing the AV sensor, please consider the following:

- Exact dimensions for the channel and the correct level of the flow stream are essential for accurate results. The importance of accurate measurements for both area and level cannot be overstated. **The 4250 makes all subsequent calculations based on these measurements.**
- Errors in level measurement are more significant at low flows, while dimensional errors become significant at higher flows. Even minor errors in measurement will have a significant and cumulative effect. For example, in a nominal 10" diameter pipe with a 3" liquid level, a measurement error of only $\frac{1}{4}$ " in the diameter of the pipe and $\frac{1}{4}$ " in the level will result in a cumulative flow error of more than 14%!
- Damage to the pressure transducer, ultrasonic transducers, electronics, or cable *will ruin* the sensor. Handle the sensor with reasonable care when installing. Do not drop or hit it. The pressure transducer is sensitive to shock. The sensor is encapsulated in a plastic potting compound and if damaged, cannot be opened for repair.
- The standard AV sensor accurately detects levels above approximately 0.1 foot (30 mm) and velocities for streams with a minimum depth of 2 – 4 inches (50-100 mm). This value is selected in programming. See Measuring Minimum Depth on page 2-14. Below the minimum depth, velocities are approximated, based on previous measurements. Although the standard sensor can measure levels less than 0.1 foot, (about one inch, or 25 mm) accuracy in this range is not guaranteed. Shallower streams should be measured using the low-profile AV sensor. Streams that run consistently below one inch are not a good application for the 4250.
- Velocity measurements depend on the presence of some particles in the water, either air bubbles or suspended solids. If the flow stream is so clear that there are neither air bubbles nor suspended solids, the velocity sensor cannot function properly and will not be able to read velocity. In such cases, it may be necessary to aerate the water upstream from the sensor with a small pump or other apparatus to ensure there is something to reflect the ultrasonic waves.
- When installing the AV sensor in a pipe or invert, mount the sensor upstream from the outfall. For the most reliable readings, place the sensor at the bottom center of the flow stream.

Although the sensor is easiest to calibrate when located at the bottom of the stream, you can locate it off-center in a larger pipe, if there are good reasons to do so. Streams that have large amounts of silt would be suitable for this. You can still calibrate the level accurately by using the offset distance to set the zero level in the program (see Page 2-14).

✓ Note

For installations where the sensor is mounted off-center, you must always have enough flow above the sensor to meet the minimum measurement depth. The AV sensor **cannot measure** either level or velocity if the flow stream falls below the sensor.

3.6.1 Level Measurement in Open Channels (No Primary Device)

When measuring level to calibrate an area-velocity installation, keep in mind the following:

- Make the measurement as accurately as possible.
- Measure the level at a point inside the ultrasonic “cone” extending upstream from the AV sensor.
- Measure level in an area of stable flow. (This may affect sensor location.)

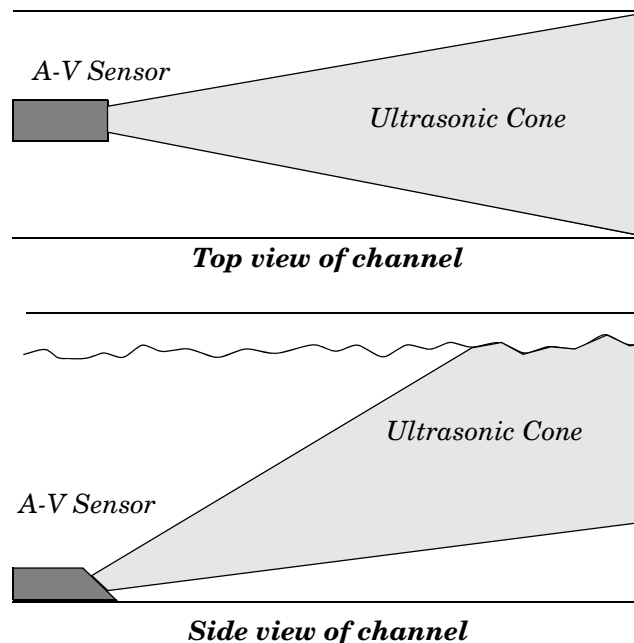

The sensor may be installed at a point offset from the bottom center line of the channel in cases where silting is a problem. However, typical installations are at the bottom center. Note how offset mounting of the sensor will change the dispersal of the ultrasonic “cone.”

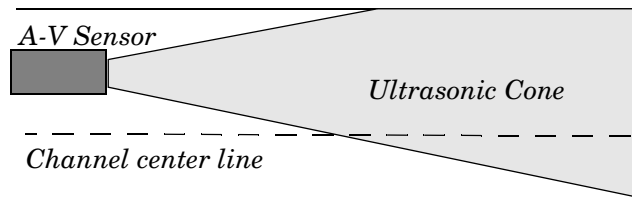

***Effect of offset mounting of sensor
(Top view of channel)***

In such cases, make sure you measure depth at a point **inside** the cone. In large channels, you may have to measure several feet upstream from the sensor.

Measure the diameter of the pipe. Then measure from the top center of the pipe to the liquid surface and subtract this distance from the pipe diameter to get the level. If the stream is not calm, average the measurements from the crest and the trough of the waves. Measure some distance **upstream** from the installed AV sensor. We suggest using a distance equal to the depth of the flow stream. For example, if the flow stream is one foot deep, you would measure level at a point one foot upstream from the sensor. Do not measure right at the sensor, as the profile of the sensor and the mounting strap may cause a “jump” or localized rise in the level. If you cannot measure upstream after installation of the sensor and strap, measure the level before installing the sensor. Do **not** measure downstream from the sensor.

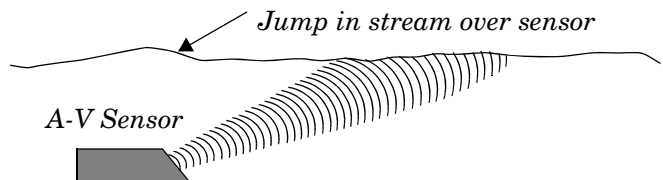

Side view of channel

If the level is low enough that you can see a visible jump or disturbance in the liquid surface where it flows over the sensor and mounting ring, you should measure the level with the sensor and ring out of the stream.

Changes in channel shape that affect the stability of the flow such as elbows, outfalls, inverts, etc. should be considered when locating the sensor. Avoid installation in areas where such changes in channel shape nearby make the flow turbulent. Instead, install where the flow has stabilized.

- You do not have to install the sensor with a primary measuring device.

The flow in this 10" round pipe is **uniform**. The ideal level measurement point is always within the ultrasonic cone – point **C**, but it is not easily accessible. In this example, level measurement at point **A** is acceptable due to the **uniform** flow.

Note: Not drawn to scale. Depths in all three examples are to show flow characteristics of each channel.

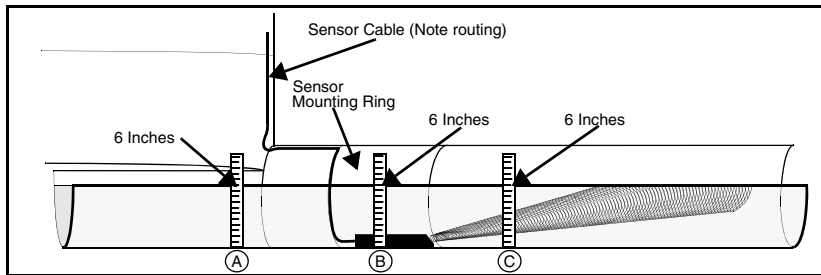

The flow in this 10" round pipe is **not uniform**, due to the low liquid level and the disturbance caused by the sensor. At point **B**, the level rises as the liquid passes over the sensor and mounting ring. Measure level at **C**. If the flow becomes uniform when the sensor and ring are removed, take a level measurement close to the sensor location.

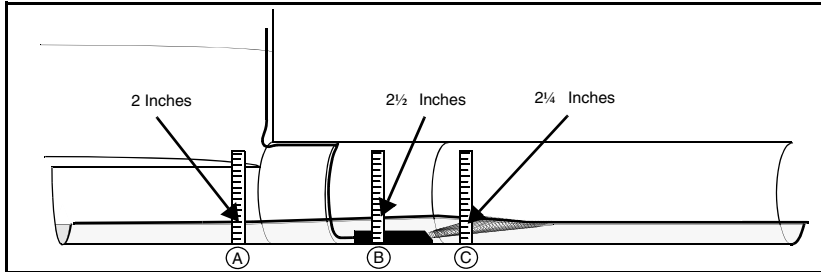

The flow at the a-v sensor is **not uniform**. The level drops sharply into the lower outfall. Similar effects would be noted in the case of an elbow or bend in the channel. In this example, the sensor should be moved forward to the uniform flow (between points **C** and **D**). Take the level measurement within the uniform flow. It might also be necessary to average several level measurements.

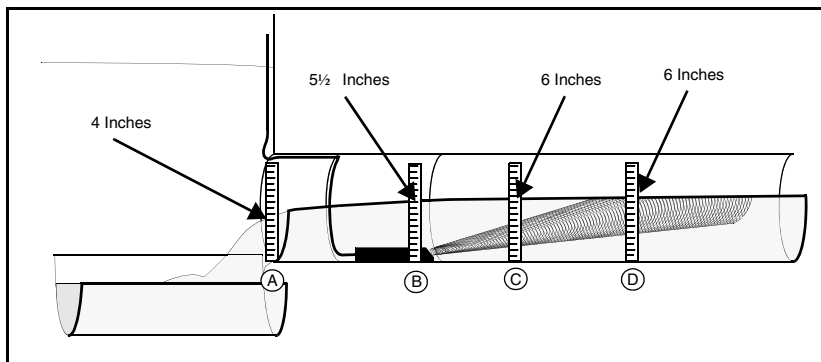

Figure 3-7 Methods of Level Measurement

However, if you do install the sensor in a channel that has a primary measuring device (weir or flume) install it upstream or downstream from the device, not inside the device.

Primary devices with narrowed passages (most flumes) change the velocity of the liquid as it passes through the device. To minimize this effect, install the AV sensor at a point where the stream velocity has returned to normal.

Install the AV sensor at the prescribed measuring point of a primary measuring device if you only want to measure level. In such instances, program the flow meter using level-to-flow rate conversion with a secondary indication of velocity, rather than area-velocity conversion (see Section 2). Information on where to install the sensor is available for most primary measuring devices from the *Isco Open Channel Flow Measurement Handbook* or from the manufacturer of the device.

3.7 Rectangular and Trapezoidal Channels

A flat, anchored mounting plate is a common mounting choice for installing sensors in rectangular or trapezoidal channels. See the *Isco Mounting Rings Installation and Operation Guide* for more information.

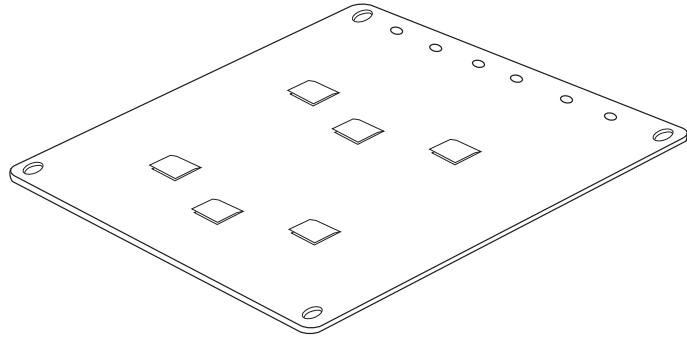

Figure 3-8 Isco Rectangular Mounting Plate

3.8 Mounting Rings for Circular Channels

Consult your Isco Mounting Rings Installation and Operation Guide for detailed hardware information.

The following sections describe sensor installation using the two options available for mounting the Sensor in pipes or round-bottomed flow streams. For pipes up to 15" (38.1 cm) in diameter, **stainless steel self-expanding mounting rings (Spring Rings)** are available. For pipes larger than 15" in diameter, Teledyne Isco offers the **Scissor Rings (Universal Mounting Rings)**. Area velocity sensors can also be installed using primary measuring devices.

3.8.1 Spring Rings

To install a spring ring, you compress the ring, slip it inside the pipe, and then allow it to spring out to contact the inside diameter of the pipe. The inherent outward spring force of the ring firmly secures it in place. A typical self-expanding mounting ring (with a probe mounted on it) is shown in Figure 3-9.

These mounting rings are available for use in pipes with inside diameters of 6" (15.2 cm), 8" (20.3 cm), 10" (25.4 cm), 12" (30.5 cm), and 15" (38.1 cm). The Teledyne Isco part numbers for the various size mounting rings available are listed in Appendix B. These part numbers include not only the ring, but also the miscellaneous hardware necessary to mount the sensor on the ring.

 **CAUTION**

Always wear leather gloves when handling the rings (either type). The metal is finished, but there is still a possibility of cutting your hands on the edges.

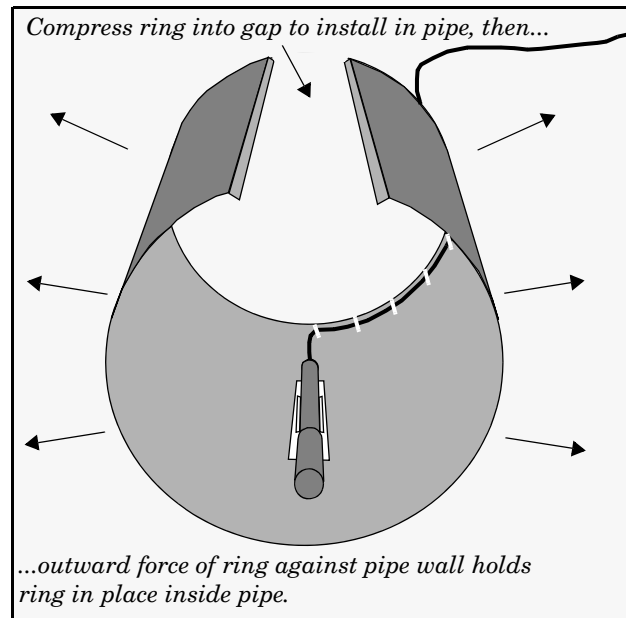

Figure 3-9 Sensor Installed on a Spring Ring

CAUTION

Make sure the slots on the sensor are completely pressed onto the tabs on the ring. This is particularly important where there is any possibility of reverse flows, or where flows are of high velocity. If the sensor is not fully pressed onto the mounting ring tabs, it might come loose in the stream, and could possibly be damaged or lost.

Completing the assembly

To complete the sensor-spring ring assembly procedure, attach the sensor cable to the downstream edge of the ring. Follow the cable routing shown in Figure 3-9. Other routing directions may affect measurement accuracy. The cable can actually create a stilling well downstream from the sensor, causing the level to read low. Use the self-locking plastic ties supplied with the ring. Install the ring in the pipe by compressing it. Press inward on both sides and slide the ring into the pipe.

Route the sensor cable out of the stream and secure it in position by placing the ties through the holes in the mounting ring and then locking them around the cable, as shown. To prevent debris from catching on the cable, it is important to attach the cable to the mounting ring so it offers as little resistance to the flow as possible.

 **CAUTION**

Make sure the sensor cable is securely fastened along the back (downstream) edge of the ring. Otherwise, the sensor may provide **inaccurate level readings** under conditions of high velocity.

Do not overtighten the plastic cable ties; they should be tightened just enough to secure the cable in place, without greatly indenting the cable. Overtightening the plastic ties may collapse the reference tube in the cable, blocking it.

The spring ring may need anchoring. Under conditions of high velocity (greater than 5 feet per second or 1.5 meters per second), the ring may not have sufficient outward spring force to maintain a tight fit inside the pipe. The ring may start to lift off the bottom of the pipe in a waving fashion, or may even be carried downstream.

This problem is more prevalent in the larger diameter pipes (10", 12", and 15", and in pipes with smooth inside surfaces, such as plastic pipes). If any of these conditions are present, or if movement of the mounting ring is detected or suspected, you must anchor the ring in place. You can do this by setting screws through the ring into the pipe, or by other appropriate means. If there is a problem with the smaller diameter rings, it may be sufficient to simply increase the outward spring force of the ring by bending it into a less round configuration.

3.8.2 Scissors Rings

For pipes larger than 15" in diameter, Teledyne Isco offers the adjustable Scissors Ring (also known as the Universal Mounting Ring). This device consists of two or more metal strips that lock together with tabs to form a single assembly. There is a base section where the sensors are mounted, one or more extension sections (usually), and a scissors section at the top that expands the entire assembly and tightens it inside the pipe. The scissors mechanism includes a long screw that increases the width as it is tightened.

The assembled rings fit pipe diameters from 16" to 80". Secure the unit in place by tightening the scissors mechanism with a $\frac{5}{8}$ " socket wrench or other suitable tool. Ring sections are .040" thick half-hard 301 stainless steel sheet. All other parts are also stainless steel, except for the plastic cable ties in the hardware kit.

Each extension, 1, 2, 3, and 4, adds 9.0", 21.5", 31.5", or 41.5", respectively, to the circumference of the ring. Used alone, the base section fits pipe that is approximately 16" to 18" in diameter. The 9.0" (the smallest) extension exists so that in larger pipe sizes, where large variations in circumference can occur, you can use one or two of these extensions to take up or remove slack, to bring the scissors mechanism into a position where it can be effectively tightened.

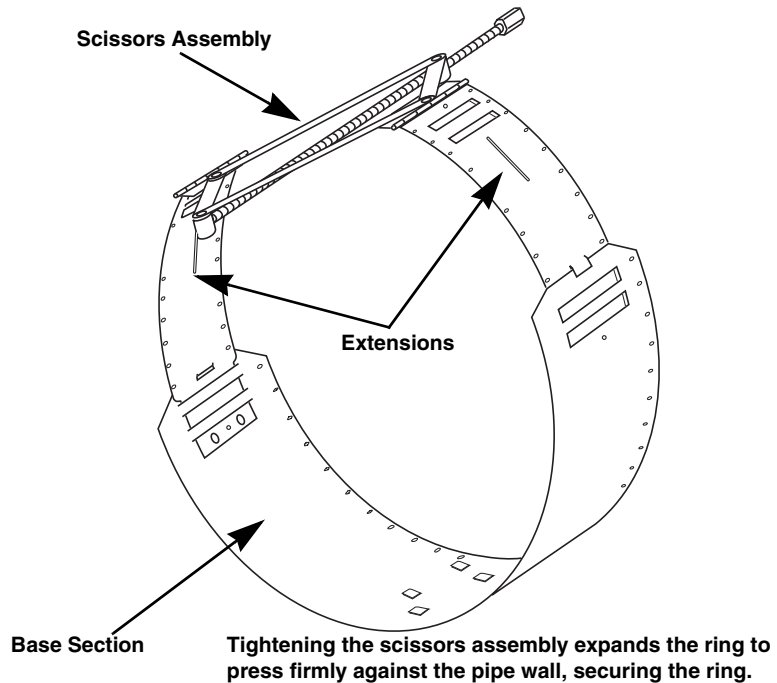

Figure 3-10 Scissors Ring Adjustment

Mounting ring kits are available for different pipe sizes. A kit is also available for partial pipe applications (consult your *Isco Mounting Rings Installation and Operation Guide*). For a listing of part numbers and ordering information, see Appendix A.

3.8.3 Completing the AV Sensor Installation

The AV sensor installation is finished by coiling any excess sensor cable and securing it using cable clamps or other means. The reference tube inside the cable can be restricted or blocked if the cable is kinked, sharply bent, or otherwise pinched. The sensor cable should be handled and mounted with care. Also, if there is any appreciable distance between the point where the sensor cable leaves the mounting apparatus and the location of the flow meter, *be sure* to attach the cable to the flow stream wall to prevent it from vibrating, moving around, tangling, or possibly collecting debris.

CAUTION

Under no circumstances should you leave any extra length of sensor cable dangling freely in the flow stream where it could trap debris or become tangled.

Use gloves and eye protection when assembling and installing the rings in a pipe. Though deburred, the edges of the stainless steel can cut if improperly handled. *Please read the information on how best to install this device.*

Observe general safety procedures when entering any manhole. See “General Safety Procedures” in the back of the manual for more information on general hazards and necessary precautions.

3.9 Sampler Interface

One of the uses of the 4250 Flow Meter is to control a sampler in a flow-paced sampling mode. Flow-paced sampling means that the flow meter is programmed to signal the sampler to take a sample after a specific volume of flow has passed through the flow stream, rather than after a particular period of time. In this mode, the sampler and flow meter will be able to compensate for varying flow rates. The 4250 Flow Meter may be used with any of the Isco Wastewater Samplers listed in Section 1.

An optional 25 foot (7.6 m) long connect cable is available to connect the flow meter to the sampler. Attach the six-pin female connector on the cable to the Sampler connector on the side of the flow meter. (This is the second connector from the top.) Attach the connector on the other end of the cable to the Flow Meter socket on the sampler. The flow meter will then be connected to the sampler's power supply, and the sampler will be able to receive flow-proportional signals from the flow meter. Refer to the sampler manual for further details.

4250 Flow Meter

Section 4 Options and Accessories

This section describes accessories available for use with 4200 Series Flow Meters. There are two groups of accessories. One group of options you can use with any of the 4200 Series. The other group are accessories for a specific type of level sensing and can only be used with one flow meter of the series. This section covers the accessories that are usable with any 4200 Series Flow Meter. Application-specific options are covered in the Installation sections of each type of flow meter.

Teledyne Isco offers the following options for use with all 4200 series flow meters:

- 4200T Modems
- 4-20 mA Outputs (Internal and External)
- Model 674 Tipping Bucket Rain Gauge
- Flowlink® Software (used with the modem or a laptop computer)
- Parameter Probes - Temperature, pH (acidity/alkalinity) and D.O. (dissolved oxygen)
- Mechanical Totalizer
- High-Low Alarm Relay Box
- YSI 600 Multi-Parameter Sonde

The 4-20 mA Output Interface, alarm box, rain gauge, and parameter probes are options you can field-install any time. The modems require factory modification to the flow meter, and you should specify these options when you order. If you want to add any of these later, you will need to return the flow meter to the factory.

4.1 4200T Modem

The 4200T Modem is a circuit board installed inside the flow meter that transmits flow meter data over standard telephone lines. The modem also makes it possible for the flow meter to receive data from compatible equipment at the other end of the phone line. Modems allow digital equipment to talk and listen to other remotely-located digital equipment over telephone lines.

4.1.1 How it Works

The analog phone system cannot transmit digital signals through repeaters; digital machines cannot communicate directly over phone lines. Modems convert the data into tones and transmit them over phone lines. The equipment on the other end of the line answers with tones through its modem. The first modem converts these tones back to digital data and interprets it. The 4200T Modem is full duplex and works in the auto-answer

mode. It operates at 300/1200/2400 baud. This modem has speech and tone capabilities and comes with a connect cable to attach to the telephone line.

 **Note**

The modem is disabled when an interrogator cable is connected to the flow meter's interrogator port. It cannot receive incoming calls, and the alarm dialout will be rendered inoperable, while this cable is connected. **Disconnect the interrogator cable in order to use the 4200T Modem.**

4.1.2 Modems and Flowlink Software

The 4200T Modem communicates with Teledyne Isco's Flowlink data storage and acquisition software, setting up the flow meter to collect blocks of data. Flowlink allows storage and interpretation of flow meter data. Other Flowlink software packages can write reports with this collected data.

4.1.3 Connection to a Telephone Line

The FCC (Federal Communications Commission) governs communications over telephone lines. Your local telephone company will provide you with the line between the flow meter and the computer. Call them for connection information. The FCC requires the following information be published for connecting the modem to the phone line.

“This equipment complies with part 68 of the FCC rules. On the case of this equipment is a label that contains, among other information, the FCC registration number and ringer equivalence number for this equipment. If requested, this information must be provided to the telephone company.”

“This equipment uses the following USOC jacks: USOC RJ11C.

“The REN is used to determine the quantity of devices that may be connected to the telephone line. Excessive REN's on the telephone line may result in the devices not ringing in response to an incoming call. In most, but not all areas, the sum of REN's should not exceed five (5.0). To be certain of the number of devices that may be connected to the line, as determined by the total REN's, contact the telephone company to determine the maximum REN for the calling area.

“If this equipment causes harm to the telephone network, the telephone company will notify you in advance that temporary discontinuance of service may be required. If advance notice isn't practical, the telephone company will notify the customer as soon as possible. Also, you will be advised of your right to file a complaint with the FCC if you believe it is necessary.

“The telephone company may make changes in its facilities, equipment, operations, or procedures that could affect the operation of the equipment. If this happens, the

telephone company will provide advance notice in order for you to make the necessary modifications in order to maintain uninterrupted service.

“If trouble is experienced with this equipment, please contact the Teledyne Isco Customer Service Department, (800) 228-4373 or, outside the U.S.A., call (402) 464-0231, for repair and (or) warranty information. If the trouble is causing harm to the telephone network, the telephone company may request you remove the equipment from the network until the problem is resolved.

“The following repairs can be done by the customer: None.

“This equipment cannot be used on telephone company-provided coin service. Connection to Party Line Service is subject to state tariffs.

“When programming and/or making test calls to emergency numbers:

“Remain on the line and briefly explain to the dispatcher the reason for making the call.”

“Perform such activities in the off-peak hours, such as the early morning or late evenings.”

4.1.4 Types of Service

The 4200T Modem is compatible with standard telephone lines and comes with a 12 foot cable. The cable connects the flow meter’s **Modem** connector to a standard telephone jack, type USOC RJ11C, supplied by the phone company. You must mount the flow meter within 12 feet of this jack.

We are required by the FCC to provide the following notice:

“This equipment generates and uses radio frequency energy and if not installed and used properly, in strict accordance with the manufacturer's directions, may cause interference with radio and television reception. There is no guarantee that interference will not occur in a particular installation. If this equipment does cause interference to radio or television reception, which can be determined by turning equipment off and on, the user is encouraged to try to correct the interference by one or more of the following measures:

- **Reorient the receiving antenna on the television.**
- **Relocate the unit with respect to the receiver.**
- **Plug the unit into a different outlet so the unit and receiver are on different branch circuits.**
- **If necessary, consult the manufacturer or an experienced radio-television technician for additional suggestions.”**

You may find the following booklet, prepared by the FCC, helpful: *How to Identify and Resolve Radio-TV Interference Problems*. This book is available from the U.S. Government Printing Office, Washington, D.C. 20402, Stock No. 004-00-00345-4.

4.2 Connection to External Serial Device

Teledyne Isco offers two serial outputs from 4200 series flow meters. There is a software-enabled output that is transmitted on the RAIN GAUGE connector. This signal also appears on the INTERROGATOR connector. This feature lets the flow meter transmit the most recent values for all currently enabled ports as ASCII text. You can select the baud rate and the frequency of transmission. You can then write a simple program to retrieve this data periodically, or you can do it interactively using a terminal program. This option (SERIAL OUTPUT) is discussed in detail in Section 2.

Teledyne Isco offers a 300 baud output on the RAIN GAUGE connector. This port provides ASCII level and flow rate data for remote transmission to any ASCII-compatible equipment. Every 15 seconds the flow meter transmits a line of data which includes level, units of level measurement, percentage of maximum flow rate, maximum flow rate, a total flow value, units of flow, sample number, bottle number, text, time, and date.

If you are using the flow meter with an Isco sampler, the data line also includes an indication of a sampling event.

You can transmit this data line to a computer, or to a locally-connected (within 250 feet) device capable of interpreting serial data, such as a video display terminal or a printer. The specifications for this serial data output are as follows: 300 baud, 7 data bits, 2 stop bits, even parity. The printed (or displayed) line contains 110 characters and will appear similar to the following:

```
+01.409F 100.00% 2.500+0 CFS    0001533+0 CF    00 00  
90 DEGREE V-NOTCH WEIR  
000 0 90 04 04 02 31 48
```

The last two characters (not displayed) are a 'CR' (carriage return) and a 'LF' (line feed). The large gaps between some of the words indicate extra character spaces which are not used in this particular text, but which are available for use if needed.

Note

You cannot use both serial outputs at the same time. You must select one or the other.

The serial output is paralleled with the Interrogator Port and the Internal Modem. Use of either the Interrogator Port or the Internal Modem will cause non-standard data to be transmitted.

4.3 4-20 mA Analog Outputs: External and Internal

These outputs provide connection between a 4250 Flow Meter and non-Isco process-control equipment, such as chlorinators, or any other type of equipment that you can control with a 4-20 milliampere current loop. Analog outputs convert digital information from the flow meter to a variable analog output current ranging from 4 to 20 milliamperes. When a condition measured by the flow meter is converted into an analog output, 4 mA becomes the 0% or baseline for the condition, while 20 mA becomes the 100% or full-scale of the condition. Teledyne Isco offers two different arrangements for providing the 4-20 mA

outputs. One is an external box that converts the signals from the flow meter to a 4-20 mA current loop. The other is an internal circuit board containing three separate analog output circuits on the same board.

The 4 to 20 mA current is an industrial standard current loop for process control equipment that must respond to changing conditions by varying output rates.

4.3.1 External 4-20 mA Output Interface

The External 4-20 mA Output Interface has its own case and AC power supply. Commercial power (120 VAC) must be available for this device. Battery operation (12 VDC) is not feasible due to voltage and current demands. It comes with a line cord, connectors, and two interconnect cables. One cable has 6-pin M/S connectors on both ends. This cable connects the input of the 4-20 mA Output Interface to the flow meter **Interrogator** connector. The other cable has a three-pin plug on it that connects to the output connector of the 4-20 mA Output Interface. This cable ends in three pigtailed wires you connect to the equipment you want to control with the 4-20 mA Output Interface.

Table 4-1 4-20 mA Output Interface Specifications	
Power	120 VAC ¹ 8 Amp.
Output Connector	3-pin male plug Pin A: + current out Pin B: – current out Pin C: not used
Output Accuracy: At 72° F (22°C) Full Oper. Range	±0.25% of full-scale ±0.5% of full scale
Operating Temperature Range	0° to 140°F (–18° to 60°C)
Resolution	0.1% of full-scale
Input Connector	6-pin male M/S Pin B: – pulse input Pin F: + pulse input Pins A, C, D, E: NC
Isolation	Output current optically isolated from flow meter.
Fusing	¹ 8 Amp. internal on AC line.
Adjustments / Calibration	Factory-calibrated; when used within range, no adjustment needed,
Maximum Distance	1,500 ft. (457.3 m) using 18 AWG wire.

4.3.2 Internal Multiple Analog Output Board

For those needing more than one analog output, Teledyne Isco offers the Multiple Analog Output Board, which is installed inside the flow meter. This board provides three isolated analog outputs. The board is compatible with the existing external 4-20 mA output box (60-1784-039). A flow meter can use either the internal board, the external box, or both, for a maximum number of four analog outputs.

 Note

If your flow meter has both the multiple analog output board and the external analog converter, the internal ports will be designated Analog Outputs 1, 2, and 3. The external ports will be designated either “External” or “Analog Output 0.”

The Multiple Analog Output Board consumes a minimum of 16 mA per output; consequently, the flow meter should be AC-powered. If you must use battery power, you should consider the following to extend battery life:

- Use a Solar Panel Battery Charger
- Use a larger battery: either a commercial deep-cycle/marine type, or an Isco 55 Ampere-hour lead-acid battery.
- Order only one analog output.
- Flow meter program choices also affect power consumption. Use “minimum” settings, if possible. (See Section 1, Table 1-6 and Section 5.)

The outputs from the analog output board are electrically isolated from the flow meter and from each other by internal DC-DC converters. The board uses the opening for the modem connector for its outputs. Normally, a flow meter will not need both the analog and modem boards. If your installation does, however, you should contact the factory.

The analog board terminates in a 6-pin male M/S connector on the flow meter case. Flow meters built with the analog board option are also supplied with an output cable. This cable connects to the wiring that runs to the equipment controlled by the 4-20 mA current loop and to the 6-pin M/S connector on the flow meter. The cable has a 6-pin female M/S connector and is provided with stripped pigtail ends for convenient wiring.

Table 4-2 Multiple Analog Output Board Specifications

Operating Temperature	0 to 140° F (–18 to 60° C)
Output Accuracy	±0.5% of full-scale
Resolution	0.1% of full-scale (0-20 mA)
Electrical Isolation	Isolated from each other and from the flow meter.
Calibration	Factory-calibrated; no further adjustments necessary.
Maximum output distance	1500 feet (457.3 m) using 18 AWG wire.
Current Range (per loop)	0 to 20 mA
Maximum Load (per loop)	750 ohms
Analog Output 1 Terminations	Pin A (Red wire –) Pin C (White wire +)
Analog Output 2 Terminations	Pin D (Brown wire –) Pin F (Blue wire +)
Analog Output 3 Terminations	Pin E (Black wire –) Pin B (Green wire +)
<p>Note: If you must strip the cable further back to facilitate wiring, you will expose an orange, yellow, and purple wire. You may disregard these wires, as they are not connected in this application.</p>	

4.4 Pacing Non-Isco Equipment

For applications requiring the conversion of the flow meter's flow proportional output signal to a fixed duration contact closure, Teledyne Isco offers the Type 'E' Interface.



Figure 4-1 Type 'E' Interface for pacing non-Isco equipment

To allow connection to a second device simultaneously, you must connect using the special Isco Y cable, part #60-5314-278. A connected sampler must have its own external power. **NEVER** connect the sampler and flow meter to the same power source.

 **CAUTION**

Do not use the standard Isco Y cable (60-3704-081) with the Type 'E' Interface. This cable is designed for Isco sampler connection only.

Use of this device requires a factory modification to the flow meter. If you are connecting the Type 'E' Interface to a previously purchased flow meter, prepare the unit by performing the steps described in this section, or contact the factory to return the unit for modification by Technical Service.

 **DANGER**

Risk of electrocution. Disconnect the flow meter from power before performing any modification or repair.

 **CAUTION**

Always protect your equipment by observing anti-static precautions when exposing internal components. Turn to Section 5.7.1 for recommended precautions.

1. Remove the four Phillips screws on the front panel. Carefully pull the panel away from the case to access the interior.
2. Remove the lower metal shield by sliding it downward, freeing the tabs from their slots. This exposes the power supply PCB.

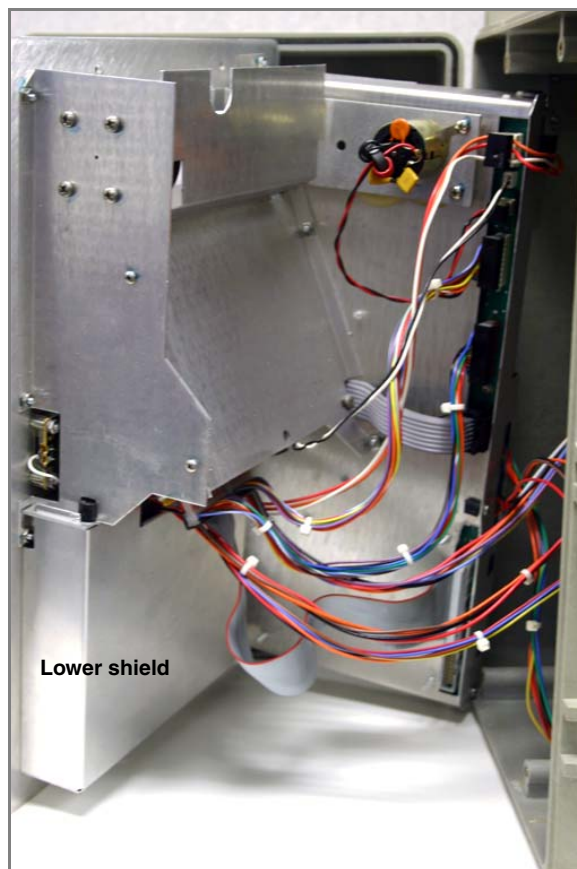

Figure 4-2 Flow meter with front panel removed

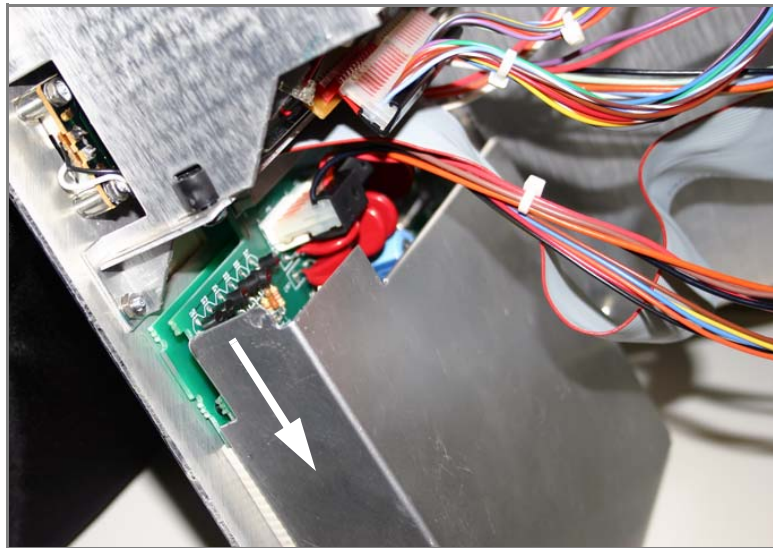
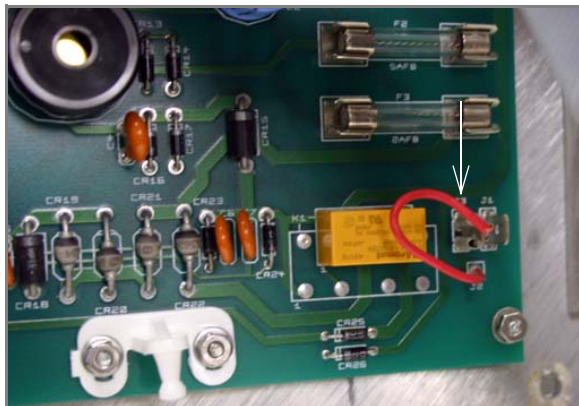

Figure 4-3 Removing the lower shield

3. In the lower right hand corner of the power supply PCB, disconnect the red wire's spade connector from J3 and connect it to J1.



Disconnect from J3.



Connect to J1.

Figure 4-4 Type 'E' modification

4. Replace the metal shield and carefully reattach the front panel to the flow meter case.

4.5 Tipping Bucket Rain Gauge

A Tipping Bucket Rain Gauge is available from Teledyne Isco for use with 4200 Series Flow Meters. The gauge connects to the flow meter by a cable terminated in an M/S connector. This connector plugs into the Remote Printer/Rain Gauge connector on the case. A Y-connect cable is available that allows use of both the rain gauge and a YSI 600 Multi-Parameter Sonde at the same time. You can connect extra cable (user-supplied) between the rain gauge and the factory-supplied cable as long as you do not exceed a maximum total length of 1,000 feet. Use 18 AWG wire or larger. **Do not cut the M/S connector from the cable.** The rain gauge is factory-calibrated to provide a contact closure to the flow meter for every hundredth of an inch (0.01") [or 0.1 mm] of rainfall. Software in the flow meter stores this information in memory and prints the accumulated data as a text line on the printer chart. It also allows the printout to be expressed in metric. You may, if you wish, provide a rain gauge of your own choice, but to ensure compatibility with the flow meter's operating environment, it must conform to the following specification:

- It must provide an isolated, dry contact closure.
- It must be a normally open contact configuration.
- It must close for 100 ms (-25 ms +150 ms) with less than 2 ms contact bounce.
- It must provide a contact closure for every 0.01" (or 0.1 mm) of rainfall

A cable assembly is available to connect a user-supplied rain gauge to the flow meter. More information about the rain gauge is available from the factory or the Rain Gauge Manual.



Figure 4-5 674 Tipping Bucket Rain Gauge

4.6 Isco Flowlink Software

Teledyne Isco offers a proprietary software system for data acquisition, storage, retrieval, and analysis. This software system, Flowlink, contains programs that allow 4200 series flow meters to store blocks of level and other data readings in the flow meter's memory. You retrieve this stored data with either a laptop computer or central computer connected to the flow meter by modem. You can use other programs in the package to process the retrieved data for further analysis. In addition to storing data, this software makes it possible to divide part of the flow meter's memory into partitions. These partitions may be formatted in "rollover" or "slate" mode of data storage. You can also set up the flow meter to store data as a result of some sort of "triggering" event, such as level rising to a predetermined point, the passage of a predetermined time interval, or the occurrence of a storm event, such as rainfall.

Consult the Factory - A detailed explanation of the Flowlink software is beyond the scope of this manual. Information on Flowlink Software is available from its manual or from the factory.

4.7 High-Low Alarm Relay Box

Teledyne Isco offers a control box that monitors flow rate data available from any 4200 Series Flow Meter. Alarm relays trip when the flow rate exceeds or falls below pre-selected limits. High and low set points are user-set and range from 0% to 99% in 1% increments. Output from the unit is the switching of form C (SPDT) relay contacts. The unit has 2 relays; one for high alarm and the other for low. The availability of form C contacts (both NO [normally open] and NC [normally closed] contacts) means you can switch loads either on or off. Relay contacts are rated 3 Amperes at 24 volts AC or DC. The alarm box operates on 12 VDC supplied from the flow meter. Current consumption in standby condition is approximately 10 mA. In alarm, current increases to 190 mA. You can connect as many as four alarm boxes to a flow meter, if the flow meter is powered from the AC line.

Note

Do not use the alarm box if your flow meter has a modem or uses Flowlink software (through either a modem or laptop computer).

Use the alarm box with caution in battery-powered installations, as it will significantly increase power consumption.

In standby condition, an alarm box consumes about one ampere-hour of battery capacity in four days (or reduces capacity approximately 25%). In alarm condition, one alarm box will completely discharge a fresh (4 Ah) battery in 21 hours. Teledyne Isco recommends using only one alarm box in a battery - powered installation, and you can expect to change the battery more often.

4.7.1 Installation

The High-Low Alarm Relay Box is enclosed in a high-strength plastic box and is easily installed. Mount the unit with corrosion-resistant hardware through the 2 holes in the stainless steel mounting plate attached to the case. Two threaded holes in the case allow the use of either 1/2" conduit fittings or compression bushings. While the alarm box is suitable for use in damp locations, do not install it where there is any possibility of submersion. Where temperatures are expected to fall below freezing, Teledyne Isco recommends installation of the alarm box indoors or in a heated location, as the manufacturer of the micro-processor does not specify its operation below 32° F (0° C).



Hazard of electric shock! Use the relay contacts for low voltage (24 V) pilot duty only. Do not wire 120 VAC or higher voltages to the relay contacts.

4.7.2 Wiring to a 4200 Series Flow Meter

Connecting the High-Low Alarm Relay Box to a 4200 Series Flow Meter requires a cable and an M/S connector. A special cable, 25 feet long, is available from Teledyne Isco. On one end of the cable is a 4-pin, male M/S connector. Plug this connector into the Remote Printer/Rain Gauge connector on the flow meter. The other end of the cable has 3 stripped wires. Attach them to the alarm box according to the instructions in the alarm box instruction manual.

BLACK	+12 VDC
GREEN	-12 VDC
WHITE	DATA

4.8 Parameter Sensing with Isco 4200 Series Flow Meters

Isco 4200 Series Flow Meters have the capability of displaying, recording, and (if Flowlink software is used) storing data provided from parameter sensors. The parameter sensors available for the Isco flow meters are for **temperature, dissolved oxygen (DO), pH**, (concerned with the acidity or alkalinity of a solution), and the **YSI 600 Multi-Parameter Sonde**. See **Section 2** for information on the YSI 600 Sonde. This section covers the Isco pH, D.O., and temperature sensors.

4.8.1 Installation of Parameter Probes

The parameter probes, as well as other Isco probes such as the submerged probe and area-velocity probe, require complete, continuous submersion in the flow stream for proper operation. Dry operation can damage the pH and D.O. probes. The YSI Sonde (only) may be suspended vertically in the stream. Teledyne Isco offers a series of rings that provide mounting for the probes in round pipes.

- Each probe snap-mounts to a specialized sensor carrier.
- The sensor carrier then attaches to the rings or mounting straps.

- The probe cable is carefully routed out of the stream.
- Only the temperature probe can connect directly to the flow meter's parameter probe connector.
- The pH and D.O. probes both connect to parameter modules (amplifiers). The pH probe connects to the 201 pH Module and the D.O. probe connects to the 270 D.O. Module. The modules are not interchangeable.

 **Note**

The 270 D.O. module has been discontinued. Probes, service kits, and accessories are still available to maintain existing field units.

Isco flow meters are built with one parameter sensing port, and can only sense temperature plus one parameter at a time, (unless you use the YSI Sonde.) You must select temperature, D.O. with temperature, or pH with temperature. If you want to change probes later, you can, but you will need to reprogram the flow meter. Note that selection of either pH or D.O. in step 1 (where **units of measure** are defined) will lock out any mention of the other in the menus for the rest of the program.

The Parameter Modules themselves plug into the Parameter Probe connector on the flow meter.

 **CAUTION**

The pH and D.O. probes require continuous submersion after installation, or they will lose sensitivity. **Prolonged dehydration of the sensor bulb may damage or even ruin the pH probe.**

4.9 Temperature Probe

The temperature probe is the simplest of the three, consisting of a thermistor inside a metal housing. The thermistor changes resistance with an increase or decrease in temperature. The flow meter converts this resistance change to a temperature reading and displays it, in degrees Celsius or Fahrenheit, as chosen by menu selection.

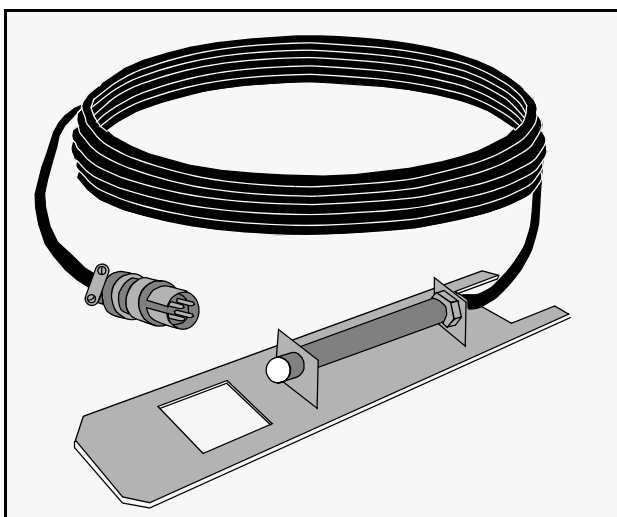

Figure 4-6 Temperature Probe

4.10 pH Probe

The pH probe measures the acidity or alkalinity of an aqueous solution by determining the relative quantity of dissociated hydrogen ions, H^+ (actually H_3O^+) in the solution. A larger quantity of H^+ ions indicates acidity, while a smaller quantity of H^+ ions indicates alkalinity. The *H* in pH stands for Hydrogen and the *p* stands for power.

The normal scale for pH runs from 0 to 14, with 0 being most acidic and 14 being most alkaline. Distilled water at 25° C is neutral at 7, based on the fact that the dissociation constant (number of H^+ and OH^- [hydroxyl] ions present) for pure water at that temperature is 10^{-7} .

The **dissociation constant** is a number indicating the degree of ionic dissociation for a substance after it is dissolved in water. Dissociation constants vary widely for substances depending on the nature of the substance's chemical bonds. Ionic salts tend to have higher constants.

Each number on the pH scale between 7 and 0 equals a tenfold increase in H^+ ion. Each number between 7 and 14 equals a tenfold decrease of H^+ ion. pH measurements of wastewater are commonly made to monitor the effect of treatment chemicals added to raise or lower the pH.

Water that has been used for various industrial processes may deviate substantially from 7. Chemicals are often added to the water to bring the pH close to that of neutral water, which is 7. For example, if the effluent has a concentration of heavy metal ions, they must be removed before discharge. Raising the pH of solutions containing transition-metal ions will cause them to precipitate, where they can easily be removed as sludge. The resultant solution will be high in pH and will require acid to neutralize it.



Figure 4-7 pH Probe (with protective cap)

The pH probe is a combination of two electrochemical half-cells. Together they provide a low-voltage signal that corresponds to the hydrogen-ion concentration of a solution. If you look at the pH probe, you will see a glass bulb on one end. This is called the glass mono electrode.

The glass is of special composition, sensitive only to hydrogen ions, and is exposed to the solution to be measured. The specific sensitivity to hydrogen ions prevents interference from other ions that may be present in the solution. It is essential to prevent grease fouling of this membrane. The glass membrane produces an electrical potential proportional to hydrogen ion activity. The other electrode, called the reference electrode, completes the circuit between the glass electrode and the solution.

The Isco pH probe combines both electrodes in a single housing and also contains an amplifier to reduce the extremely high impedance of the circuit. This improves the reaction of the probe to stray capacitance and reduces interference caused by electrical noise in the vicinity.

pH measurement is affected significantly by temperature, like any other chemical reaction. Consequently, temperature compensation is provided in the flow meter. The Isco pH probe has a built-in temperature sensor that is exposed for faster response.

The pH probe connects to a Parameter Module that plugs into the Parameter Port on the flow meter. The probe has a 25 ft. (7.6 m) cable. For greater distances, contact the factory. The maximum distance between the module and the flow meter is 1,000 ft. (304.8 m).

When the ion-selective electrode and the reference electrode are connected to a high-impedance voltmeter and submerged in a solution, ions move to the surface of the membrane. The electrical charge on the ions creates a potential difference across the barrier between the solution and the membrane. This potential, or voltage difference, is proportional to the activity of the ions in the solution.

The potential, when read by a sensitive voltmeter, translates into a reading of pH. With an Isco flow meter, the voltage is sent first to a preamplifier inside the probe to reduce the impedance of the circuit and improve the signal-to-noise ratio, and then on to the

parameter module to allow greater operating distance from the flow meter. The flow meter determines the pH value and displays it.

4.10.1 pH Probe Calibration

The 4250 provides a two- or three-point calibration for the pH probes with commercially-prepared calibrated buffer solutions. Calibrations of 4 and 7, 7 and 10, and 4, 7, and 10 are all possible. For accurate readings you must clean and re-calibrate the probe on a regular basis. How often you need to do this depends on the condition of your flow stream. Flow streams with a high grease content will coat the sensing surfaces of the probe quickly, clogging them and slowing the response time or stopping it altogether. **Installation in very greasy flow streams is not recommended.**

Note

For pH probe calibration, Teledyne Iso recommends that you use a glass container for the buffer solutions to ensure that the following conditions are met:

The probe must be properly submerged in solution, and there must be no air trapped under the probe membrane, or the reading may become incorrect and/or erratic.

Do not touch the probe until after you have performed step 6.

To calibrate the pH probe with the flow meter:

1. Go to program Step 1: PROGRAM, SETUP and select PROGRAM.
2. Step through the units of measure with the **Enter** key until you reach the menu that says pH UNITS - NOT MEASURED, pH. Select pH. You must do this in step 1 or the pH menu will not appear later.
3. Now go to step 3. PARAMETER TO ADJUST - NONE, LEVEL, pH (other selections may appear.) and select pH. If the pH menu does not appear in step 3, go back to step 1 to make sure you have turned it on. Then the pH selection of calibrations will appear.
4. Place the pH probe in the appropriate buffer solution until the stainless steel body is one inch beneath the surface.
5. If you select 4 & 7, the following screen will appear. Calibration with the other menu options (7 & 10 or 4, 7, & 10) is essentially the same as shown below. For the other menus, see Section 2.

RINSE PROBE AND PLACE IN 4.0 pH SOLUTION
PRESS ENTER WHEN STABLE: X.XX pH

6. Wait for the reading to stabilize (this may take from 30 seconds up to 5 minutes). When the probe has stabilized, press **Enter** and the following display will appear:

RINSE PROBE AND PLACE IN 7.0 pH SOLUTION
PRESS ENTER WHEN STABLE: X.XX pH

When you have entered this second value, the pH probe calibration is complete. You can then install the probe in the flow stream.

 **Note**

An asterisk (*) may occasionally appear next to the pH reading for approximately 30 seconds, during which time the most recent reading will be displayed. This may be normal flow meter operation due to other internal functions, or could indicate pH fluctuation in the stream.

4.10.2 pH Probe Installation Guidelines

Installation of the pH probe is similar to the submerged level sensor and other parameter probes.

- Install the probe only in streams that have continuous flow. The sensing end of the probe must always remain wet.
- For proper operation, there must also be enough flow to submerge the sensing end of the probe completely.

If flow in the stream is intermittent (dry for periods of time), the pH sensing bulb will dry out and its response time will slow. This is a problem in situations where pH changes rapidly. If the probe is dry long enough, it will first lose sensitivity, then be slow to respond, and finally stop working. Never let the sensing end of the probe dry out completely.

- Installation in streams with high grease content will result in poor performance and require frequent cleaning and recalibration.

Greasy substances, being nonconductors of electricity, weaken the electrical potentials formed between the glass mono-electrode and the solution, slowing or halting the response altogether.

The pH Sensor operates satisfactorily mounted either horizontally or vertically in the stream. However, horizontal mounting is more secure, and presents less of a debris trap.

- Simple suspension of the probe is not recommended, particularly in streams of high velocity, or those that carry debris.

If you mount the pH probe vertically, mount it securely. Do not just hang it from the top of the pipe by its cable. Suspending the probe in the stream is not stable.

For horizontal mounting, the probe fastens to a sensor carrier that snap-fits to an Isco mounting ring. The mounting rings fit various diameters of round pipes 15" diameter and smaller. For larger pipes, use the **Isco Universal Mounting Ring**. For installation details, refer to the instruction sheet supplied with the mounting ring.

The mounting rings are held in place by the outward force of spring pressure in the smaller sizes and by a screw arrangement in the larger sizes. After mounting the probe in the ring or strap, route the cable out of the stream so it will not trap debris that could clog the sewer.

Mount the **pH Module** within 25 feet of the probe, but in a location higher than the highest anticipated level for the flow stream. The amplifier box is sealed and will withstand temporary submersion, but this should be avoided.

Note

Do not connect an Isco pH probe and temperature probe to the 201 module at the same time. The “Temperature Probe” input on the 201 module is for use ONLY with non-Isco pH probes that do not have built-in temperature sensing. The Isco pH probe contains its own integral temperature sensor, which, if connected in parallel with a separate temperature probe, will cause erroneous readings.



Figure 4-8 pH Parameter Module

Note

When installing the pH probe and its sensor carrier, make sure the mounting slots on the carrier are completely pressed into the mating tabs on the ring. The probe relies on a full engagement between tabs and slots for secure mounting. If the slots are loose against the tabs, the probe may be swept away by the force of the stream.

Always mount the probe in an easily-accessible location, because you will need to clean it from time to time. Also, all pH probes are consumable items, meaning that they will eventually fail and have to be replaced. The probe is due for replacement when you

can no longer calibrate it (after cleaning) to ± 0.2 pH with the standard buffers of 4, 7, and/or 10. Another indication of end-of-life is when the probe calibrates satisfactorily, but takes too long to stabilize (more than 10 minutes). Such a probe could not possibly respond to rapidly-changing pH. If your situation requires fast response, you should consider replacement when stabilization time reaches 5 minutes.

You can mount the probe facing either upstream or downstream, but Teledyne Isco recommends facing upstream, as there is a stop on the sensor carrier that is not effective when the probe is facing downstream. Remember to unscrew the rubber guard cap from the sensing end of the probe when you install it, or the probe will be unable to sense the flow stream.

The guard cap is to protect the probe during shipment and storage and to keep the glass membrane and liquid junction from drying out. If you remove the probe for any reason, clean it and replace the cap after filling with 4.0 buffer solution. **Never store the probe dry or without the cap in place.**

The Isco amplifier box extends the allowable distance between the probe and the flow meter. The probe has a 25-foot cable, so you must mount the amplifier within this distance. The maximum distance between the amplifier box and the flow meter is 1,000 feet.

Table 4-3 pH Probe Specifications	
Description	Submersible, horizontal-mounting probe with combination-type electrodes. Porous Teflon [®] liquid junction to resist fouling and coating. Steam-sterilized glass hemi-bulb for long-term stability.
Size	6" long \times $\frac{3}{4}$ NPT.
Body Material	Stainless Steel.
pH Range	0 to 14 pH units.
Temperature	32° to 176° F (0° to 80°C).
pH Accuracy	± 0.1 pH units over the full range.
pH Electrode Junctions	Double porous junction
Temperature Compensation	Performed by software inside the flow meter. The standard pH Probe contains an integral temperature sensor.

4.10.3 Storage and Maintenance of pH Probes

If you remove the pH probe from operation, be careful to keep the glass sensor bulb wet. Always store the probe with the rubber cover screwed completely over the threaded end of the sensor. Exposure to air causes the glass membrane on the sensor bulb to dry out. This makes it very slow to respond in solution. **Prolonged or repeated dehydration of the bulb will ruin the probe.**

The pH sensitive glass can also become “conditioned” to its environment, especially when it is continuously exposed to high pH (10 and above) solutions. The glass does have a memory and will respond slowly when exposed to a lower pH solution after having been in a high pH solution for any significant period of time.

Storage of a pH probe in a 4.0 buffer solution is recommended as this has a regenerative effect on the glass and does not put a memory on it. Tap water will work if 4.0 buffer solution is not available. Deionized water is good for quick rinses to clean the element, but not for prolonged storage of an electrode. Continuous exposure of the ion-sensitive membrane to a wetted, but non-ionic solution will improperly condition the membrane.

The reference electrode is also adversely affected when allowed to dry out. Salt crystals from the electrolyte or precipitates of the solution measured will form salt bridges, either within or on the surfaces of the liquid junction, causing the reference to be less conductive and resulting in a higher reference impedance.

This condition will typically worsen until the unit no longer functions. Soaking the reference electrode in a 4.0 pH solution, or tap water if the buffer is not readily available, may bring the reference back to life. Boiling the electrode in 4.0 buffer solution or tap water could revive the electrode in more severe situations. If none of these solutions work, it may be necessary to replace the probe.

4.11 Dissolved Oxygen (D.O.) Probe

This probe measures the amount of oxygen dissolved in a stream or waterway. Oxygen dissolved in water is necessary for many forms of life that dwell in lakes and streams. Inadequate supplies of dissolved oxygen will cause fish and other aquatic life that depend on them as a food source to die off or be sharply diminished in numbers. The measurement of dissolved oxygen content is of interest to those monitoring the condition of lakes and streams. Fish must have a certain minimum concentration of dissolved oxygen to thrive, typically 4 to 6 mg/l.

Various types of pollution can cause the amount of oxygen dissolved in water to drop sharply, placing the aquatic life forms at serious risk. The D.O. probe measures the amount of oxygen dissolved in water in a range from 0 to 20 mg/l. Note that the flow meter can display D.O. in either mg/l (milligrams per liter) or ppm (parts per million) depending on your choice in programming.

 Note

The D.O. module has been discontinued. Probes, service kits, and accessories are still available to maintain existing field units.

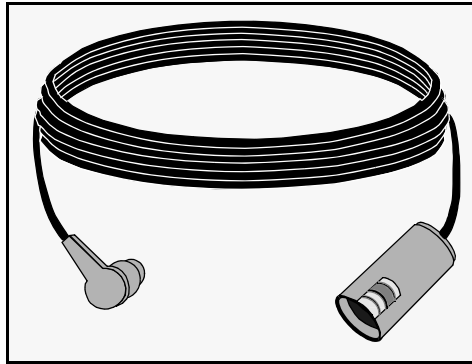

Figure 4-9 The D.O. Probe

For effective use of the D.O. Probe, please read and consider the following before making the installation:

- The D.O. Probe requires constantly moving water. The probe consumes oxygen during operation; this will deplete the oxygen available from stagnant or stratified waters, resulting in an inaccurate reading. Do not install it in a stilling well or in any location where water movement is intermittent or very low. As a guideline, a minimum velocity of one foot per second is suggested.
- Frequent maintenance is necessary when the probe is installed in flows with grease or solids content. Tests conducted by Teledyne Isco with probes installed in various waste streams have indicated that greases and solids quickly coat the probe's membrane, making it impossible for oxygen to enter the reaction chamber. This will result in an abnormally low reading, or no reading at all.
- Cleaning the membrane is generally not effective, as it tends to drive the solids further into the membrane pores. You must usually replace both the electrolyte and the membrane to get an accurate reading. In severe cases of fouling it may be necessary to change the membrane very frequently, even as often as every other day.

4.11.1 How the D.O. Probe Works

A thin, permeable membrane stretched over the sensor isolates the electrodes from the environment, but allows gases to enter. When a polarizing voltage is applied across the sensor, oxygen that has passed through the membrane reacts at the cathode, causing a current to flow. The membrane passes oxygen at a rate proportional to the pressure difference across it. Since oxygen is rapidly consumed at the cathode, it can be assumed that the oxygen pressure inside the membrane is zero. Hence, the force causing the oxygen to diffuse through the membrane is proportional to the absolute pressure of oxygen outside the membrane. As the oxygen partial pressure varies, both the oxygen diffusion through the membrane and the probe current change proportionally.

4.11.2 Probe Preparation

The following describes how to prepare a new probe for use, or how to change membranes on an existing probe. First, unscrew the sensor guard; remove the O-ring and membrane, then thoroughly rinse the sensor with distilled water. Prepare the KCl electrolyte according to the directions on the bottle. Use distilled water only. You install the membranes by hand. The probe is shipped with a small folder containing several replacement membranes.

Steps for installing a new membrane:

1. Secure the probe body so it is in an upright position. You can use a vise, adjustable wrench, or locking pliers, etc., whatever is satisfactory. Do not apply too much force to the probe body, or you will crack it.
2. Fill the cavity around the silver anode with electrolyte to the point where any more electrolyte would spill over. The liquid should be free of bubbles and should completely cover the tip of the sensor.
3. Lightly lay the membrane across the top of the probe. If you do this carefully, there will be no bubbles under the membrane.

Note

Handle the membrane material with care, touching it at the ends only.

4. Place the O-ring on top of the membrane, generally conforming to the circumference edge of the probe.
5. Place the thumb and index finger from both hands opposite each other on the O-ring at equal distances.
6. Roll the O-ring down over the end of the probe, being careful not to touch the membrane where it covers the probe.
7. Trim off excess membrane with scissors or a sharp knife. Check to see that the stainless steel rod (thermistor) protruding below the liquid cup is not covered by extra membrane.

Note

There must be no bubbles under the membrane and no creases in it for the probe to function correctly.

8. Shake any excess KCl solution from the probe. Reinstall the sensor guard. Keep the sensor in a humid environment when not in use and between measurements. The plastic bottle that was placed over the end of the sensor when it was shipped is ideal for this purpose. Place a piece of moist tissue inside the bottle, and slide the bottle over the probe.

4.11.3 Membrane Thicknesses

Teledyne Isco supplies a 2 mil (.002") thick membrane for use with the D.O. probe. This membrane is recommended for long-term monitoring situations only, typical of our users' appli-

cations. Use only this thickness membrane with D.O. probes connected to Isco flow meters. Do not use other thickness of membranes as the Parameter Module used with the probe is calibrated only for the 2-mil membrane, and cannot be recalibrated in the field. Do not use other membrane thicknesses or inaccuracy will result. Besides, the thinner membranes are very fragile and difficult to install.

4.11.4 Probe Installation

The D.O. probe attaches to a sensor carrier bracket that snaps into an Isco mounting ring. Use the specific size mounting ring for pipes less than 15" in diameter, and the universal mounting ring for pipe sizes greater than 15" diameter. Refer to the instruction sheet supplied with the mounting ring.

Note

When installing the D.O. probe and its sensor carrier bracket, make sure the mounting slots on the sensor carrier are completely pressed into the mating tabs on the ring. The probe relies on a full engagement between tabs and slots for secure mounting. If the slots are loose against the tabs, the probe may be swept away by the force of the stream.

4.11.5 Probe Operation and Precautions

The following factors determine the life of the D.O. probe and the frequency of service.

- Membrane life depends on use. Membranes will last longer if installed properly and treated with care during use. Contents of the flow stream are also important, as some substances will foul the membrane very quickly. Erratic readings will result from loose, wrinkled or fouled membranes, or from large bubbles in the electrolyte reservoir. If erratic readings or evidence of membrane damage occur, you should replace the membrane and the KCl electrolyte.
- In environments where the membrane becomes rapidly coated with oxygen-consuming or oxygen-evolving organisms, erroneous readings may occur. Chlorine, sulfur dioxide, nitric oxide, and nitrous oxide can affect readings by reacting like oxygen at the probe. If your readings seem unreasonable, you may need to perform analysis to determine whether these gases are the cause. Long-term use, as for monitoring, can magnify the effect of these factors in some applications.
- Avoid any environment containing substances that may attack any of the probe's materials. Some of these substances are concentrated acids, caustics, and strong solvents. The probe materials that come into contact with the sample include FEP Teflon, acrylic plastic, ABS plastic, EPR rubber, stainless steel, epoxy, polyetherimide, and the polyurethane cable covering.
- For correct probe operation, the gold cathode must always be bright. If it is tarnished (which can result from contact with certain gases) or plated with silver

(which can result from extended use with a loose or wrinkled membrane), you need to restore its surface. You can return it to Teledyne Isco or clean it yourself with a probe reconditioning kit. (This kit is available from Teledyne Isco.) Never use chemicals or any abrasive not supplied with this kit. It is also possible for the silver anode to become contaminated, which will prevent successful calibration. Try soaking the probe overnight in a 3% ammonia solution; then rinse with deionized water, recharge with electrolyte, and install a new membrane. If you are still unable to recalibrate the probe after several hours, return the probe to Teledyne Isco for service.

- If the sensor O-ring is worn or loose, you should replace it. The probe comes with a kit of O-rings and replacement membranes. Additional replacement O-rings are available from Teledyne Isco in an O-ring replacement pack.
- If the probe is not going to be in constant use, you should store it in the plastic bottle provided in shipping. To keep the electrolyte from drying out, place a small piece of moist towel or sponge in the bottle and insert the probe into the open end. If you need service for your D.O. probe, Teledyne Isco recommends returning the unit for evaluation. In addition to servicing the probe, we can also provide advice on product applications, and you can also purchase other accessories for use with the D.O. probe. Use only 2-mil membranes with D.O. probes connected to Isco flow meters.

Table 4-4 D.O. Probe Specifications

Cathode	Gold
Anode	Silver
Membrane	FEP Teflon; 2 mil standard
Electrolyte	Half-saturated KCl (Potassium Chloride)
Temp. Range	0° to +45° C
Polarizing Voltage	0.8 Volts (Nominal)
Probe Current in Air at 30° C	19 microamps (nominal)
Probe Current in Nitrogen at 30° C	0.15 microamps or less
Connection	12 ft. (3.2 m) cable with 5-pin male M/S connector
Response Time	Typical response for dissolved oxygen, using supplied membranes, is 90% in 20 seconds. Response at low dissolved oxygen levels is typically 90% in 60 seconds.



Figure 4-10 D.O. Parameter Module

You must use the Isco 270 D.O. Module box between the probe and flow meter; this extends the distance between the probe and the flow meter to 1,000 feet.

4.11.6 Calibrating the D.O. Probe with a Flow Meter

Prepare the probe as described above if this has not already been done (fill the probe cavity with electrolyte and seat the membrane).

Note

You must use the Isco Temperature Probe with the D.O. Probe to provide temperature compensation.

Wrap both the D.O. Probe and Temperature Probe in a damp cloth. Wait ten minutes for it to stabilize, then proceed.

Go to **step 1** on the flow meter. Select PROGRAM, then step through the units of measure with **Enter** until you reach the menu for pH measurement. Select NOT MEASURED. Press **Enter**. Then D.O. UNITS will appear. Select either MG/L or PPM. Press **Enter**. Exit the program and re-enter going to **step 3**.

You must select measurement of D.O. in **step 1** or the D.O. menu will not appear in **step 3**. If you cannot get the D.O. menu to appear in **step 3**, recheck your selections in **step 1**. Remember that you must select NOT MEASURED for pH in **step 1** or D.O. will not appear on the menu for the rest of the program.

SELECT PARAMETER TO ADJUST
NONE LEVEL D.O.

Select D.O. Press **Enter**. This display will appear:

D.O. CALIBRATION
D.O STANDARD, ABS BAROMETRIC PRESSURE,

Altitude is just off the screen. You can select D.O. STANDARD if this calibration medium is available to you. Do not select ABS (absolute) BAROMETRIC PRESSURE unless you are at sea level or know how to correct for this value. The barometric pressure provided from the Weather Bureau is corrected for altitude. Select ALTITUDE.

ALTITUDE UNITS OF MEASURE FT, M

Then:

ENTER ALTITUDE ALTITUDE = XXXXX FEET (or meters)

Enter the altitude for your location. This is critical to the probe's accuracy. The following display will then appear:

WRAP D.O. PROBE IN MOIST CLOTH PRESS ENTER WHEN STABLE: X.XXX MG/L

The reading is in milligrams of oxygen per liter. If you chose PPM in program step 1 for D.O. units, the reading would be in parts per million.

4.12 Installation of Parameter Probes in Mounting Rings

The parameter probes and their carriers snap onto Isco Spring Rings and the base section of Isco Scissors Mounting Rings. You can also install them in other ways with custom hardware as is appropriate for your situation. For information on the Spring Rings and the Scissors Mounting Ring, refer to Section 3.8.

4.13 The YSI 600 Multiple Parameter Sonde

The YSI 600 Sonde is a multi-purpose water quality measurement and data collection system. It is intended for use in research, assessment, and regulatory compliance. The YSI 600 Sonde can measure the following water qualities:

- Dissolved Oxygen
- Conductivity
- pH
- Salinity
- Total Dissolved Solids
- Temperature

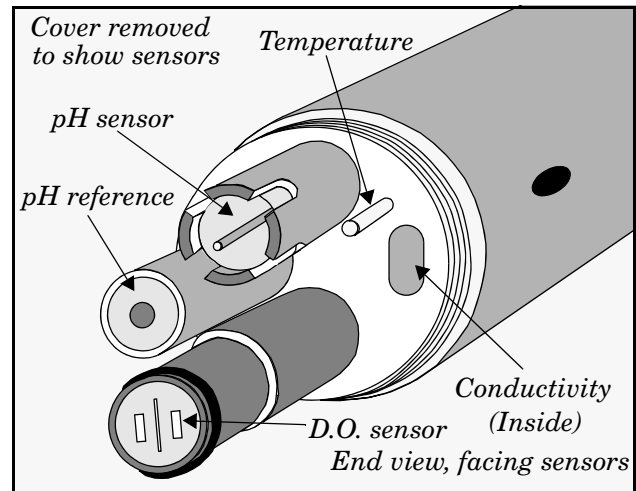

Figure 4-11 The YSI 600 Multiple Sensor Sonde

The YSI 600 is ideal for profiling and monitoring water conditions in industrial and wastewater effluents, lakes, rivers, wetlands, estuaries, coastal waters, and monitoring wells. It can be left unattended for weeks at a time with measurement parameters sampled at your selected interval and data transmitted to the flow meter. You can use the YSI 600 as deep as 200 feet below the surface, or in as little as a few inches of water. The fast sensor response of the YSI 600 makes it ideal for vertical profiling. Its small size means it can fit inside two-inch diameter monitoring wells.

A Rapid Pulse Dissolved Oxygen Sensor eliminates the need for stirring, providing accurate results without an expensive and bulky stirrer. Because no stirring is required, no supplemental power supply or battery is needed, and sensor drift caused by passive fouling is minimized.

The YSI 600 communicates with any 4200 Series flow meter equipped with suitable hardware and software. Data can be exported through Flowlink software for further processing.

The YSI 600 connects to a modified 9-pin Rain Gauge Terminal on any 4200 Series Flow Meter. Operation of the Rain Gauge with YSI 600 is still possible with a special Y-connect cable. Modification of older 4200 Series Flow Meters is possible with changes in connectors and boards. For additional information, contact Teledyne Isco.

The YSI 600 is available with a cable 25 feet long to connect to the flow meter. The cables are waterproof at the sonde and can be used in lab or field.

Information about programming the flow meter to use the YSI 600 is found in Section 2 of this manual. Information about the YSI 600 Sonde is found in the YSI manual.

4.14 Mechanical Totalizer

A mechanical totalizer is available for the 4250 that consists of a seven-digit, non-resettable mechanical counter mounted in the front panel. It must be ordered with the flow meter. The totalizer advances according to program selections for units of measure and the maximum flow of the primary device used. The totalizer is internally set to advance at $\frac{1}{100}$ of the rate of the display totalizer. Consequently, you must multiply the number shown on the mechanical totalizer by 100 to determine the actual value for total flow.

4250 Flow Meter

Section 5 Maintenance and Service

5.1 Routine Maintenance and Minor Service

The following sections provide routine maintenance and servicing instructions. Included are sections on cleaning the flow meter, reactivating the desiccators, maintaining the bubble line, servicing the internal printer, elementary troubleshooting and servicing CMOS circuitry.

Teledyne Isco recommends that you become familiar with the maintenance procedures presented here. While the 4250 is ruggedly built to withstand severe field conditions, it will function best and remain most reliable if you follow these simple procedures.

5.1.1 Care of the Flow Meter Case

If you close and latch the lid, and cap all the M/S connectors on the side of the case tightly, you can clean the case by spraying it with a hose or washing it with soapy water. Do not use a hose with a nozzle or a high pressure hose-and-wand. Do not immerse the flow meter in a tank of water to wash it. The flow meter can usually withstand accidental submersion in water, if that should occur, but it is not intended for routine submersion.

5.1.2 Care of the Case Seal

From time to time you should inspect the case seal and clean it, if necessary. The ridge around the edge of the case and the groove on the cabinet door form a seal when the door is closed. Keep this seal free of dirt, sand, etc. If it isn't, clean it carefully with a damp cloth. Also keep the rubber gasket in the lid clean. You can clean it with a small brush and a damp cloth. If you do any cleaning while the case is open, be careful not to let any dirt or debris fall inside the flow meter assembly. It is best to work on the flow meter with the case standing upright. If you don't maintain the seals properly, they may leak, causing damage and eventual failure of the components inside.

5.1.3 Preventing Moisture Damage

To prevent moisture damage to the internal components, keep the lid tightly latched at all times, except when it is necessary to change the program or change the chart. Do not operate the flow meter routinely with the case open. This will expose the internal components to dirt and moisture; it will also saturate the desiccant canister inside the case very quickly. Inspect this canister periodically and recharge it as necessary as described subsequently. It is also important to keep the external connectors clean by keeping the mating connectors or the protective caps tightly screwed down. Under severe operating conditions you can spray the threads of the connectors with a cleaner/lubricant such as Jif or WD-40 to prevent corrosion. Be careful not to spray any of the terminals (pins or jacks) inside the connectors; residue from the sprays could cause intermittent or failed connections.

5.2 Reactivation of the Desiccators

The 4250 has a reusable desiccant canister held by a steel clamp on the inside of the case lid. There is also a tubular desiccant cartridge on the top of the case next to the connectors. The canister contains silica gel that adsorbs moisture trapped inside the flow meter's case when it is closed. This keeps the inside of the case completely dry during shipment, storage and use. If you leave the case open, the desiccant will quickly absorb moisture from the surrounding air and will soon be saturated. It will no longer be able to protect the flow meter. Both desiccators use a color indicator that changes from blue to pink, or yellow to green, when saturated. The external desiccant cartridge vents the reference port of the pressure transducer.

5.2.1 When to Recharge the Desiccant in the Tubes

Both the 4250 and the optional Quick Disconnect Box dry the probe's vent tube with a desiccant tube. Inspect the desiccant tube frequently. Exposed to humid air constantly, the desiccant will become saturated quickly. If the desiccant is unable to dry the vent tube and the tube becomes blocked with moisture, the level readings will be unreliable, and the probe can suffer permanent internal damage.

Teledyne Isco uses silica gel (SiO_2) in the desiccant tubes and canisters:

- One looks like small beads or pellets that are blue-black when dry, pale pink to transparent when saturated.
- The other looks like coarse sand, yellow when dry, dark green when saturated.

Regenerate silica gel before all the desiccant in the tube turns pink or green by heating.

Another type of desiccant may be used in the tubes: anhydrous calcium sulfate (CaSO_4). Calcium sulfate looks like rough chips of tinted plaster and changes from blue when dry to rose-red when saturated. Regenerate the calcium sulfate desiccant before all the desiccant in the tube turns rose-red. **Do not put calcium sulfate in the metal desiccant cartridge.**

The filters in the ends of the desiccant tube prevent desiccant particles from entering the vent line. When they become soiled, replace them with cotton balls.

The desiccant in the tube requires periodic recharging to dry it after it becomes saturated with moisture. After repeated recharging, it eventually requires replacement.

Note

Both desiccants, anhydrous calcium sulfate and silica gel, are regenerated in the same way but require different temperatures. Calcium sulfate requires temperatures of 400° to 450° F; silica gel requires temperatures of 212° to 350° F.

Either chemical may produce irritating fumes when heated. See Appendix D Material Safety Data Sheets for silica gel desiccant information.

To regenerate all desiccators safely, follow these guidelines:
Always use a vented, circulating forced air convection oven in a

well ventilated room.

DO NOT use a microwave oven to recharge the desiccant cartridge. Heating the metal cartridge case in a microwave oven will damage the oven.

Leave the room while heating the desiccant.

Avoid heating the desiccant longer than necessary.

Use the recommended temperature. Avoid heating the desiccant at higher than recommended temperatures.

Do not heat the plastic desiccant tube. It will melt in the oven.

5.2.2 Regenerating the Desiccant Canister

Look at the desiccant canister each time you open the case. The canister has a window on its side that appears blue or yellow when the desiccant is dry. As the desiccant absorbs moisture, the window will turn pale pink or green. When the window is pink or green, you need to regenerate the desiccant, or replace it with the spare canister provided in the flow meter accessory package. Remove the canister from the flow meter by pulling outward on the spring clamp, releasing its hold on the canister.

Remove the canister and heat it in a **vented** oven in a well-ventilated room at 300°F (150°C) for about three hours, or until the blue or yellow color returns. Do not use a microwave oven; the metal case of the canister could cause arcing. After cooling, reinstall the canister in the flow meter. Make sure the window on the side of the canister remains visible.



Figure 5-1 Location of the Desiccant Cartridge

MSDS (Material Safety Data Sheets) for these chemicals are provided at the back of this manual.

 **CAUTION**

There have been reports of irritating fumes coming from the desiccant during regeneration. While our attempts to duplicate the problem have been unsuccessful, we still urge you to use caution.

- Use a vented oven in a well-ventilated room.
- Do not remain in the room while the regeneration is taking place.

To regenerate the desiccant cartridge:

1. Carefully snap it out of its bracket.
2. Pull the silicone tubing from the end of the cartridge.
3. Remove one of the end caps from the cartridge by twisting and pour the saturated desiccant into a metal, ceramic, or other heat-resistant container.
4. Identify the desiccant and heat it at the proper temperature two to three hours, or until the blue or yellow color returns.
5. Do not try to regenerate the desiccant inside the cartridge; the cartridge is plastic and will melt.
6. Refill the cartridge with the regenerated desiccant (or with the extra desiccant provided in the accessory package.
7. Replace the end caps.

Notice the foam filters in the end caps; they keep small pieces of the desiccant material from falling out of the cartridge. You can clean these filters from time to time using ordinary dish soap and water, then allow to dry.

 **Note**

Regeneration of the desiccators is extremely important.

Saturated desiccators let the flow meter draw moisture inside, exposing both mechanical and electronic components to water and/or chemical contamination. The air in many installations contains fumes that will form acids in the presence of moisture. These acids may corrode electrical components, particularly connectors and circuit boards.

Moisture drawn into the area-velocity probe's reference port vent tube will disable the probe.

Unseen damage caused by moisture will eventually ruin the flow meter. For maximum equipment life and reliability, inspect the desiccators regularly and regenerate them when necessary.

5.3 Care of the AV Sensor and Cables

The area-velocity sensor and its cable require little periodic maintenance unless there is a great deal of debris in your flow stream. Certain materials that swell when wet, such as sawdust, can clog the ports of the probe, blocking the hydrostatic pressure of the stream from reaching the transducer.

The pressure transducer is on the bottom of the probe. If you remove the mounting plate from the probe body, you will see a protective plate attached with two screws. The pressure transducer is behind this disk. In general, it should not be necessary to remove this disk, and Teledyne Isco strongly recommends that you do not. In the standard AV sensors, removing the plate will expose the paper-thin diaphragm of the transducer. Read the following sections carefully before attempting to disassemble the probe.

 CAUTION
--

If you disassemble the AV sensor for cleaning, do not touch the stainless steel diaphragm with your fingers or tools. The diaphragm is very thin (<0.003"), and easily bent.

The slightest deformation may result in damage to the transducer or the placing of a permanent offset on it. In either case the AV sensor will be ruined. Do not drop the assembly or subject it to any physical abuse.

5.3.1 Low Maintenance

The pressure transducer, the ultrasonic transducers, and the electronic components of the area-velocity sensor are encapsulated in plastic resin and are not user-serviceable. If any part of the sensor fails, contact the Teledyne Isco Service Department.

It may be beneficial to periodically clean the flow stream up- and downstream from the area-velocity sensor to maintain the hydrostatic conditions on which the level measurements and level-to-area conversions are based. The sensor was designed to expose a small frontal area and a streamlined profile to the flow, and that reduces the possibility of accumulating deposits of solid materials.

5.3.2 Cleaning the Standard AV Probe

Rarely, organic materials may become jammed inside the AV sensor's liquid ports. If this material swells as it becomes saturated with water, it may cause inaccurate pressure transmission to the level sensor. In the unlikely event that both entrance ports in the AV sensor become blocked with material that does not permit the pressure above the probe to be transmitted to the pressure transducer, you can clean the sensor with the following procedure:

1. Remove the AV sensor from the flow stream.
2. Scrape any accumulated solids from the exterior of the sensor body with a brush.
3. Remove the three screws holding the sensor carrier plate to the bottom of the probe. Be careful not to lose the small

spacer disk between the the sensor mounting plate and the screw at the front of the sensor.

4. Flush the underside of the sensor with water. Do not remove the protective disk and round gasket from the level sensor unless you can see that the ports are blocked with solids.
5. If the ports are clogged and do not clear with the running water, you may have to **carefully** remove the disk and gasket. Removing the disk exposes the delicate, paper-thin metal diaphragm of the pressure transducer. **Do not touch the diaphragm with fingers or tools.**
6. Gently flush with water, without training the stream directly into the cavity. **Forcing water or air directly against the diaphragm can ruin the probe.**

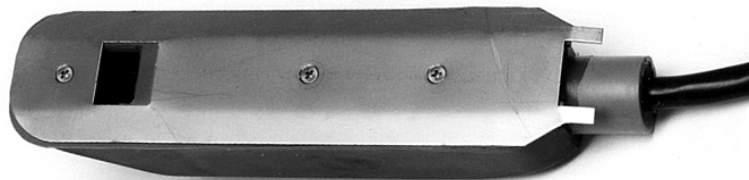

Figure 5-2 Standard AV Probe with Mounting Plate

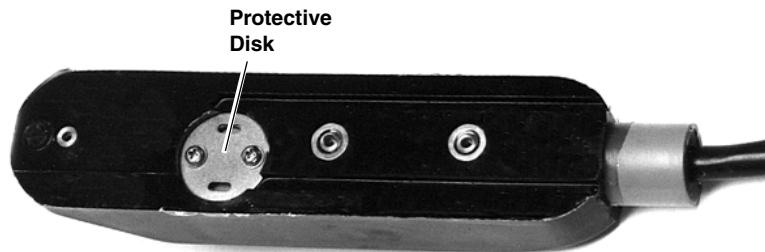

Figure 5-3 Standard AV Probe, Protective Disk Exposed

5.3.3 Cleaning the Low Profile AV Probe

The low profile AV sensor is cleaned in the same manner as the standard AV sensor. However, the transducer is encased in stainless steel. Nevertheless, do not insert anything into the vent holes when cleaning the transducer area.



Figure 5-4 Low Profile AV Probe Without Mounting Plate



Figure 5-5 Low Profile Probe With Transducer Housing Revealed

5.3.4 Cable Inspection

Periodically inspect the AV sensor cable for wear caused by abuse or exposure to the elements. Damaged cables can affect the operation of the probe, particularly if the reference port vent tube inside the cable is collapsed or blocked. Unless the damage is very close to the connector, which can be replaced, a probe with a damaged cable is not repairable.

Keep connectors clean and dry. Although connectors are sealed, if moisture penetrated a loose connection or uncapped connector, the connector and/or probe could be ruined. In permanent installations, install the cables so they are not at risk of damage resulting from other activity taking place in the area.

In temporary installations, do not leave cables lying around where they may be run over by heavy equipment. Do not leave extra cable loose in the flow stream where it can tangle and trap debris.

In permanent installations, cables repeatedly subjected to rough environments will fail and should be installed in conduit for protection. The conduit will have to be large enough to pass the connector.

 CAUTION
--

Avoid putting heavy pressure on the probe cable or making sharp bends in it when installing or servicing the probe. Excessive pressure may collapse the cable, crushing the reference vent tube. Sharp bends may cause the cable to kink, also blocking the vent.

When securing the cable with plastic cable ties, tighten them only enough to secure the cable; do not tighten them so much that the cable jacket is visibly deformed.

5.4 Maintenance of the Printer

The internal printer needs little maintenance beyond changing the chart roll and the ink ribbon.

Refer to the pictures provided for each section. Also refer to the label inside the cabinet.

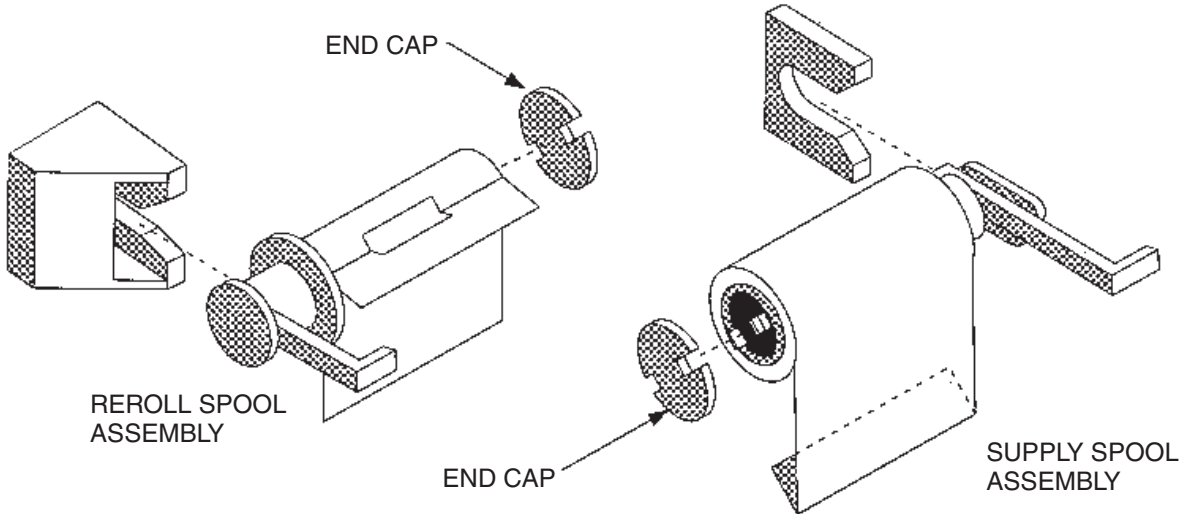

1. REMOVE REROLL AND SUPPLY ASSEMBLIES, AND REMOVE WHITE CAPS.
2. PLACE EMPTY SPOOL ON REROLL ASSEMBLY AND NEW SPOOL ON SUPPLY ASSEMBLY. REPLACE BOTH END CAPS.
3. FOLD END OF NEW PAPER AS SHOWN AND REINSTALL SUPPLY ASSEMBLY.
4. INSERT PAPER END INTO PLOTTER ENTRANCE (MARKED BY ARROW ON PLOTTER) AND PRESS CHART ADVANCE.
5. ADVANCE PAPER SO SEVERAL INCHES EXTEND FROM PLOTTER.
6. REINSTALL REROLL ASSEMBLY AND TAPE END OF PAPER TO EMPTY SPOOL.

Figure 5-6 Changing the Chart Paper

5.4.1 Changing the Roll of Paper

To change the chart paper you will need:

- a new roll of paper
- a knife or a pair of scissors
- a small piece of tape

The printer will shut down when the paper runs out. The roll is nearly empty when a 1-inch wide pink band appears on the left side of the chart.

To remove the used roll:

1. Locate the handle on the left side of the take-up roll.
2. Pull straight out on this handle until the take-up roll slips off the printer.
3. Remove the paper roll from the take-up spool by holding the handle in one hand with your thumb pressed against one of the slots in the white end cap.
4. Snap the white end cap free from the two black catches on the end of the spool.
5. Pull the paper roll off the spool with your other hand.

6. Remove the feed spool by pulling on the handle extending from the right side of the printer.
7. Snap off the other white end cap as described previously. Save the white end caps; you will reuse them.
8. Remove the empty roll from the spool by holding the handle in one hand and pulling the roll from the spool with the other.

To install the new chart paper:

After you remove the empty roll,

1. Slide the new roll onto the feed spool so it unrolls from the back side - facing away from you.
2. Line up the slots in the cardboard tube with the raised guides on the spool.
3. Reattach the white end cap by wedging the two catches on the end of the spool into the two slots on the white end cap.
4. Peel the paper back gently so it will unroll freely. Using the knife or scissors, cut off the end of the roll if it is torn.
5. Fold the paper over on itself so the end is straight and stiffer than a single layer of paper would be.
6. Unroll a few inches of the paper and set the roll on top of the cabinet.
7. Use your fingers to feed the paper down the back of the internal printer to where it touches the roller. Make sure the paper gets past the lever for the paper sensing switch.
8. Press the Chart Advance key and hold it until the paper comes through the printer mechanism.
9. When the paper comes through, reinstall the feed spool with the new roll on it by snapping it into the printer assembly.
10. Run a few inches through the printer, using the Chart Advance key; then unfold the end.
11. Put the cardboard tube from the empty roll on the take-up spindle and reattach the white end cap by wedging the catches on the end of the spool into the two slots on the white end cap.
12. Use the piece of tape to attach the end of the new paper to the cardboard tube from the old roll.
13. Roll some of the paper onto the spool so that it will wind clockwise, facing away from you. Then reinstall the take-up roll into the top of the printer.
14. Be careful to push it all the way back in, so that the take-up gear on the end of the spool assembly will reengage.
15. When the take-up spool is back in place, push the Paper Reroll key; this will remove any slackness in the paper.

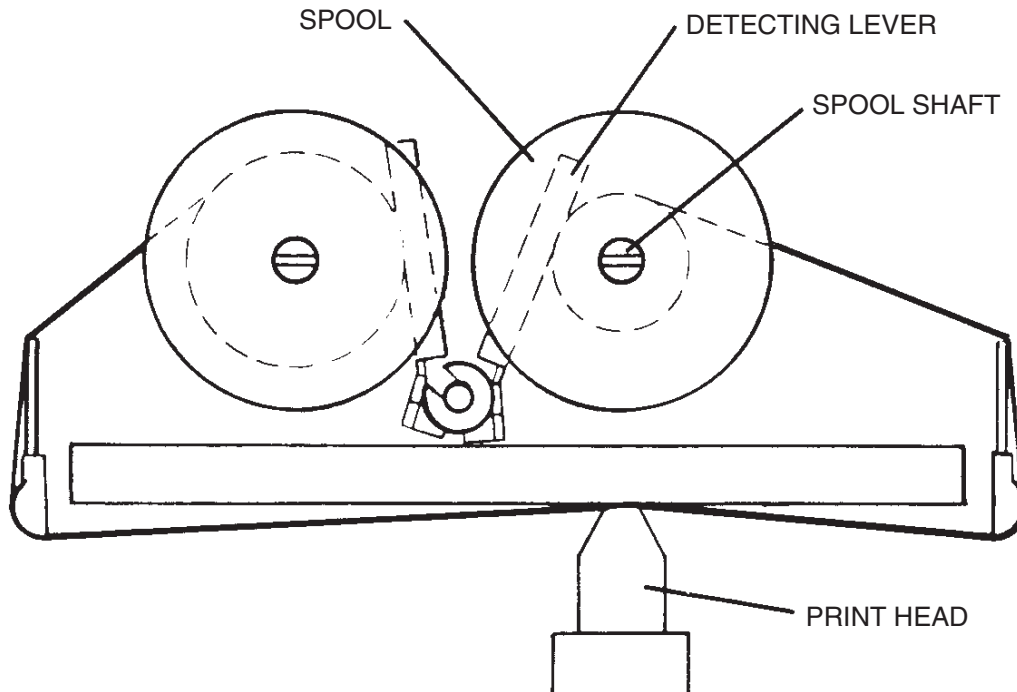

Figure 5-7 Changing the Ink Ribbon

5.4.2 Ink Ribbon Replacement

Ribbon life will vary greatly from one installation to another depending on how often the printer has to print. When the characters on the chart become difficult to read, you should replace the ribbon. If possible, try to replace the ribbon at the same time you change the paper roll, as it is easier to replace the ribbon when the roll of paper is out of the way.

To replace the ribbon:

1. Turn the unit off.
2. If there is paper in the unit, pull out the take-up spool and unroll enough paper to get it out of the way, so you can clearly see the two ribbon spools. Each spool has a ribbon-detecting lever pressing against the ribbon. Note the direction the ribbon leaves the left spool and how it winds onto the right spool.
3. Take hold of one of the spools and rotate it slightly, loosening the ribbon.
4. Hold the detecting lever away from the spool while gently pulling the spool until it comes free from its shaft. Do the same with the other spool.
5. Lift the chart and take-up spool out of the way and remove the ink ribbon from the printer mechanism, noting how it threads through the unit.
6. Thread the new ink ribbon through the printer mechanism.

7. Locate the three small pins on each spool of the ink ribbon and turn the spools so the pins face the gears on the two ribbon shafts.
8. Replace the two spools on their respective shafts, pushing the detector levers out of the way so the spools will easily re-engage their gears.
9. Gently rotate each spool to tighten the ink ribbon. Reinstall the paper take-up roll if necessary.

5.4.3 Do Not Disassemble or Lubricate the Printer

You do not need to oil the printer mechanism. As long as you keep the lid closed, keep the inside of the cabinet clean, and do not abuse the printer in any way, it should function normally. Teledyne Isco recommends you make no attempt to oil or disassemble the mechanism if it malfunctions.

Oil attracts dirt; some oils can become gummy over time and may cause parts to bind or stick. Do not attempt to disassemble the printer mechanism, as you may bend or distort the frame or component parts. This will certainly cause malfunction.

Do not force any part of the mechanism with tools or probes. If you disassemble the flow meter, do not lift the chassis from the case by holding on to any part of the printer. The internal printer contains no user-serviceable parts other than the paper and the ribbon. If the printer needs service, Teledyne Isco recommends you return the flow meter to the factory.

5.5 Servicing And Troubleshooting

The remainder of this section provides servicing information and a general troubleshooting guide. This information will help you decide whether to attempt to repair the flow meter yourself or return it to the factory.

Included are sections on removing the flow meter chassis and fuse replacement. There are also general comments on servicing electronic equipment with special consideration of CMOS circuitry.

5.5.1 Disassembling the Flow Meter

You can remove the flow meter chassis from the cabinet for inspection and servicing. Unscrew the four screws, two at the top, and two at the bottom, that hold the flow meter chassis in the cabinet. You can then lift the chassis out by inserting the thumb or index finger from each hand into the upper right and lower left corners of the opening for the internal printer.

Do not try to lift the flow meter out of its case by holding on to any part of the printer mechanism. This could bend or distort part of the printer, possibly damaging it. Once the chassis has cleared the case, you can hold onto the edges with both hands and lift it free of the case.

 **Note**

If you disassemble the flow meter for servicing, you will also remove the aluminum chassis covers to access the circuitry. Always replace these covers when repairs have been completed. The covers protect the circuit boards and also reduce signal emissions that could interfere with the operation of nearby electronic equipment. For the same reason, do not remove any of the ferrite beads or alter the wiring harnesses inside the cabinet in any way.



Figure 5-8 Lifting the Flow Meter from the Case

5.5.2 Fuse Replacement

With the flow meter chassis out of the cabinet, you can locate and change fuses. The fuses are located on the printed circuit board directly behind the keypad. There is an aluminum cover over this board. Remove the cover by pressing against its surface with the palm of your hand and then pulling downward on it with your fingers. A plastic catch under the cover holds it in place. The fuses are labeled F1, F2, and F3. The proper size for each of these fuses is:

F1 - 5 amp., fast blow

F2 - 5 amp., fast blow

F3 - 2 1/2 amp., fast blow

Always replace a blown fuse with one of the same value. Using a larger value fuse could cause serious damage to the flow meter or to its power supply. Replace the protective cover, making sure the two ears on top of the cover slide into the mating slots on the chassis. There should be a noticeable snap when the plastic catch re-engages the cover.

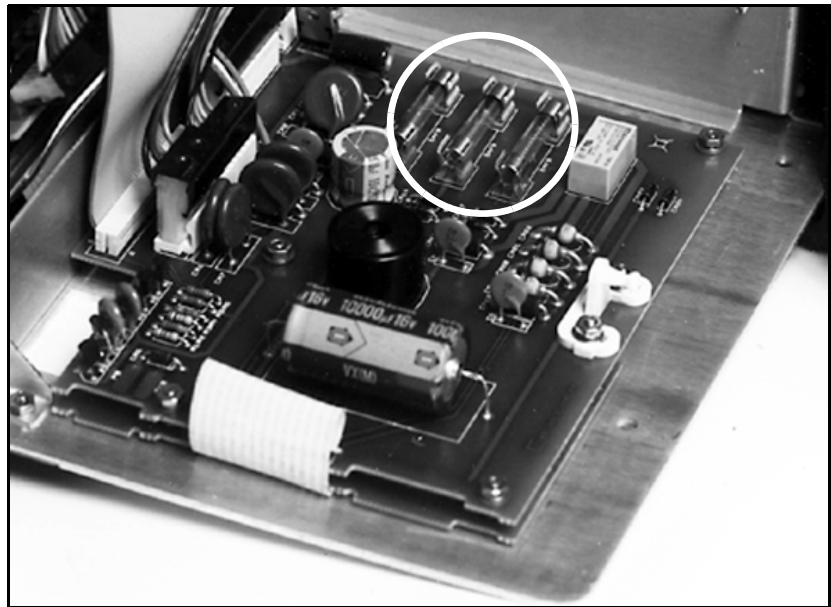

Figure 5-9 Location of the Three Fuses

5.5.3 Display Warnings

The LCD will show various warnings and error messages to warn of problems in the program, or difficulties inside the flow meter. Some messages request routine maintenance; others point out programming errors; still others indicate serious internal difficulties.

Following are typical warning messages displayed by the LCD:

CHECK PRINTER FUSE
PRINTER JAMMED
PAPER OUT

5.5.4 System Reset

If the flow meter does not appear to be operating normally, you can try to restart the processor by turning the unit off, waiting a few minutes, and then turning the unit back on. If that doesn't work, you can reset the software.

CAUTION

This procedure will cause most programmed entries and accumulated data stored in the 4250 to be lost, and the flow meter will revert to factory default settings. If this operation is performed, it will be necessary for you to reprogram the unit to meet the specifications of your installation. Use **Print Program** to keep a record of how you programmed the unit.

To reset the 4250 software:

1. Press **Print Program** for a record of your program setup.
2. Turn the flow meter off.
3. Hold down the **4** and **Exit Program** keys simultaneously.

4. While still pressing the **4** and **Exit Program** keys, turn the flow meter on again. Wait until the display reappears before releasing the keys.

Pressing **4** and **Exit Program** may leave some values programmed into the flow meter's computer. If you want to remove *all* programmed entries, hold down **1** and **Clear Entry** while powering up the flow meter.

The following messages describe serious internal problems, indicating service is required:

ROM CHECKSUM ERROR - or -

FOUND BAD RAM - CALL CUSTOMER SERVICE

If these messages appear, call the Teledyne Isco Customer Service Department at (800) 228-4373.

 CAUTION
--

Do not attempt to disassemble or repair the 4250 Flow Meter (other than changing fuses) unless you are skilled in the evaluation and repair of microprocessor-based circuitry. Teledyne Isco recommends no attempt be made to disassemble or repair the printer mechanism or display module.

5.6 Preliminary Troubleshooting Steps

The electronic circuitry of the 4250 is solid-state and its reliability is high. If the unit should fail to operate properly, the problem is most likely a mechanical failure. Items such as a broken or intermittent connections in the power cable or wiring harness or (rarely) poor electrical connection through keypad switches should be suspected.

5.6.1 If Serious Problems Occur

If you suspect an electronic problem, Teledyne Isco recommends that you contact the Technical Service Department. **Contact information can be found on the Warranty page at the back of this manual.** Our Technical Service Department has trained technicians and specially designed equipment necessary for timely, efficient repair of the 4250 Flow Meter. If you still wish to attempt repairs, the Customer Service Department is available to provide additional advice and information on servicing.

5.6.2 Inspection Protocol

When attempting to isolate problems within the unit, you should assume that the CPU and memory are working properly until attempts to find problems in the peripheral circuitry have been exhausted.

This is for two reasons:

- The likelihood of failure is far greater on transistor drive circuits (heavier currents are handled here), than on the CPU or memory.
- The CPU and memory are not serviceable and must be replaced if found to be faulty.

Following are suggested areas to check before attempting to service the 4250's circuitry. Telephone consultation with Customer Service is strongly recommended. Look for the following:

1. Verify that the problem is in the flow meter and not caused by the area-velocity probe, probe cable, Quick-Disconnect Box, power supply, or other equipment connected to the flow meter.
The flow meter could be all right and will appear to malfunction because of clogged or leaking tubes or other components; check these first. **Pay particular attention to the connectors and cable from the submerged probe.**
2. Check all 3 fuses to see if they are blown (see Figure 5-9).
3. Check the battery or power supply.
Proper voltage to the unit should be from 10.5 to 14.5 VDC. If the unit is powered from the AC supply, make sure the branch circuit is delivering at least 110 VAC to the power supply cord.
4. Check the wiring harnesses, connectors, and solder joints. Under normal conditions these should stay in good condition. However, physical stress, or operation of the unit with the door open or the desiccator saturated could cause corrosion of the connectors in certain atmospheres.
5. Look for physical damage.
Burnt, broken, or overly hot components, stuck or inoperative switches, or water damage, may be apparent if you look closely.
6. Look for shorted or open diodes and transistors, especially driver transistors.
7. Check the voltage regulators.
The output voltage from the regulators should be within 5% of their rated value. Check to see that rated voltages are available at various places on the boards.
8. Look for excessive current draw from some or all the circuitry.
This will usually be accompanied by an unusual amount of heat coming from some component or group of components, and the voltage on the power rails may well be depressed.
9. Check the input signals to the unit and see that they are correct.
This may require the use of an oscilloscope. You may need to consult Customer Service for the proper appearance of wave forms.
10. Check to see that the crystal oscillator is operating and at the proper frequency.
11. Check the reset circuitry to see that it is working properly.

5.7 Precautions for Servicing CMOS Circuitry

Most of the circuitry in the 4250 Flow Meter is made up of CMOS components. Because of the oxide gate structure of these devices, they are extremely susceptible to destruction caused by the discharge of static electricity through their inputs.

Note that many of the driver transistors in the 4250 are power MOS devices; they are just as susceptible to static damage as CMOS ICs are. Because of this risk, certain precautions must be taken when working on these circuits.

5.7.1 Hazard of Static Electricity

The voltage levels present from static buildup due to walking over carpeted floors, movement of woolen or synthetic clothes over chair seats, workbenches, etc., are high enough to destroy CMOS circuitry when performing repair work.

Ideally, all tools, soldering irons, etc., should be grounded, and work should be conducted on a grounded metal workbench, with grounding straps worn on the wrists of personnel. It is recognized that in most field repair situations, such precautions are impractical. However, certain extreme hazards must be avoided.

- Never perform any work in a room with a carpeted floor.
- Always roll up sleeves so that your arms are in contact with the working surface.

- Avoid using a work surface made of an extremely good insulator.

Plastic and glass are good insulators and should be avoided. A metal surface is best; a wood surface is acceptable. Conductive grounding mats are available for work stations and are worthwhile if much repair is to be done.

- The degree of hazard depends on the level of humidity. Be particularly careful if the work area is extremely dry, or if the work is being done in cold seasons, when indoor forced heating and outdoor low temperatures cause the relative humidity level to be very low.

- Keep yourself grounded when handling disassembled equipment.
After a unit has been opened for repair, always touch the metal chassis before touching any of the circuit components.

- Be especially careful handling the CMOS integrated circuits when they are removed from the rest of the circuitry.
Simply being connected to the rest of the circuitry provides some protection. Most of the circuitry is well-protected from damage caused by static discharge when the unit is powered up. However, an IC should never be replaced when the unit is turned on.

- Individual CMOS semiconductors and built-up printed circuit boards should always be transported in conductive packaging.
Foil is satisfactory; metallized plastic bags work well. Ordinary plastic bags and pink poly are not satisfactory

unless the legs or leads are also stuck into a block of black conductive foam. If purchased replacement components do not come in marked, protective packaging, do not use them. They may already be destroyed.

- Once assembled and soldered, printed circuit boards are easily damaged by improper repair procedures. Do not attempt to remove components, particularly ICs, from printed circuit boards unless skilled at this procedure. After a defective component is replaced, the unit still may not work if excessive heat or pressure has broken the foil traces or pulled the cores from holes on the board.

5.8 Software Updates

Update Isco Instrument Software installs software in Isco instruments and modules. This application will transfer a binary file from your PC to the instrument's flash memory.

Updated binary files are available from Teledyne Isco when enhancements have been made to the instrument software. Contact the factory for help with obtaining these files.

CAUTION

Updating the instrument software or resetting the instrument may completely erase readings and reports stored in the instrument's memory. Collect the data from the instrument before proceeding.

5.8.1 Updating the Flow Meter Software

The flow meter should be powered and turned on.

Connect your computer to the flow meter using the Computer Connect Cable (Interrogator Cable) and start the program Update Isco Instrument Software.

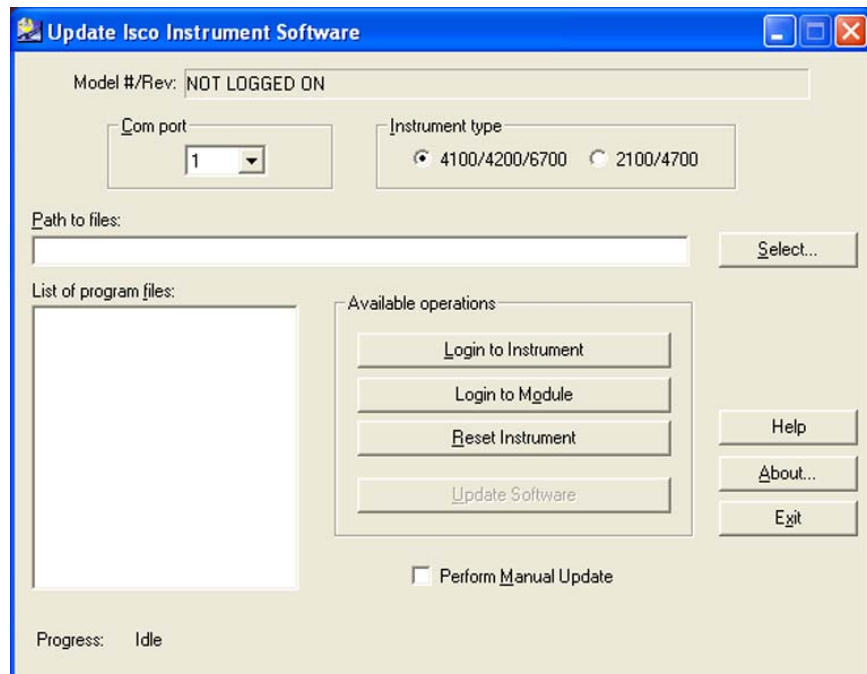

Figure 5-10 Open the software update program

Click the Help button and follow the steps listed under Update Instrument Software. Do not disturb the connection or stop the update while the file transfer is taking place. When the transfer is complete, the program displays an “Operation successful” message. Click OK and close the program.

Your flow meter’s software is now updated and ready for operation.

4250 Flow Meter

Appendix A Replacement Parts and Accessories

A.1 Replacement Parts

The following section contains illustrations and corresponding tables of 4250 Flow Meter replacement parts. A list of accessories and optional equipment can be found at the end of this section.

Replacement parts can be purchased by contacting Teledyne Isco's Customer Service Department.

Teledyne Isco, Inc.

Customer Service Department

P.O. Box 82531

Lincoln, NE 68501 USA

Phone: (800) 228-4373

(402) 464-0231

FAX:(402) 465-3022

E-mail: IscoInfo@teledyne.com

4250 Flow Meter
 Appendix A Replacement Parts and Accessories

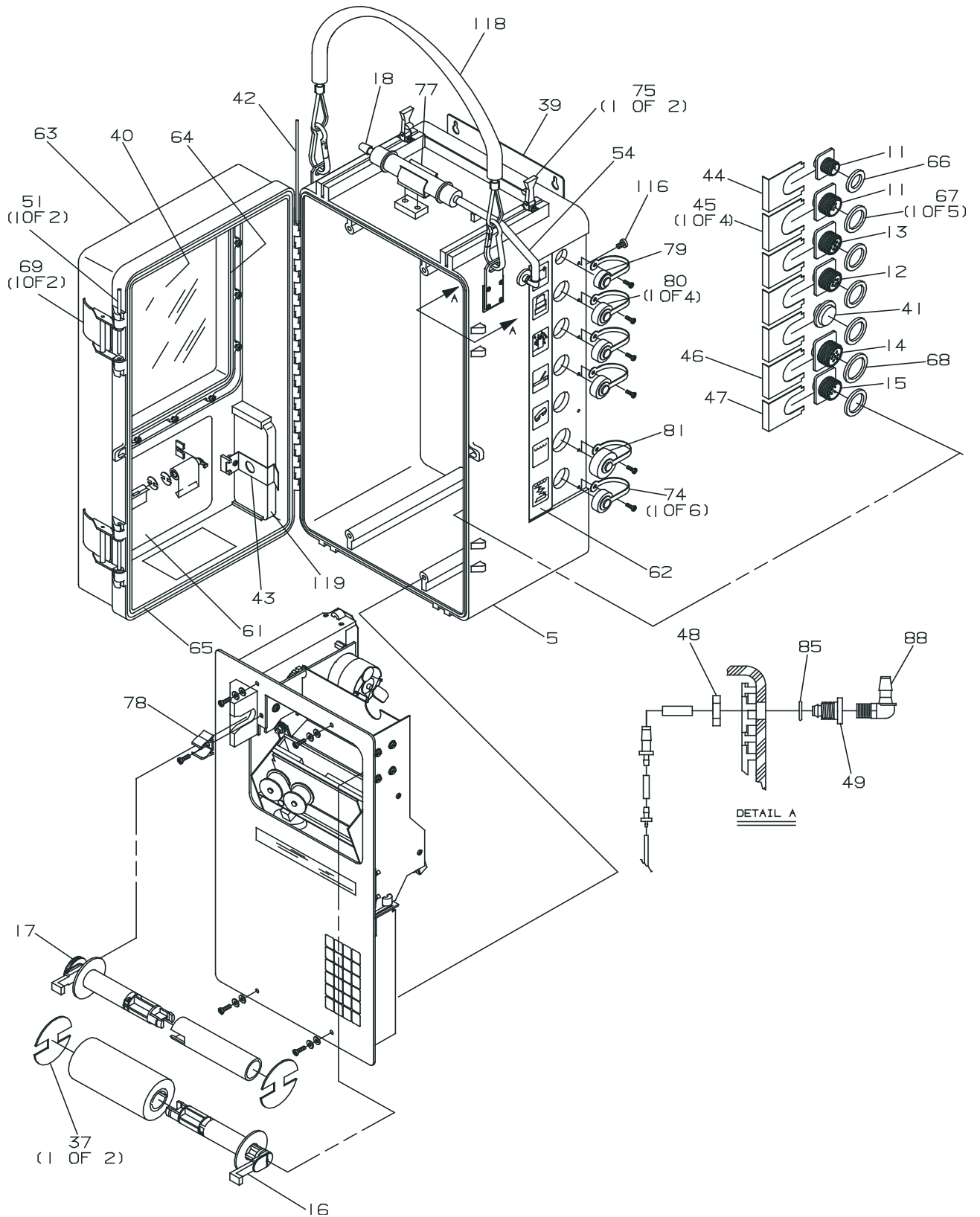

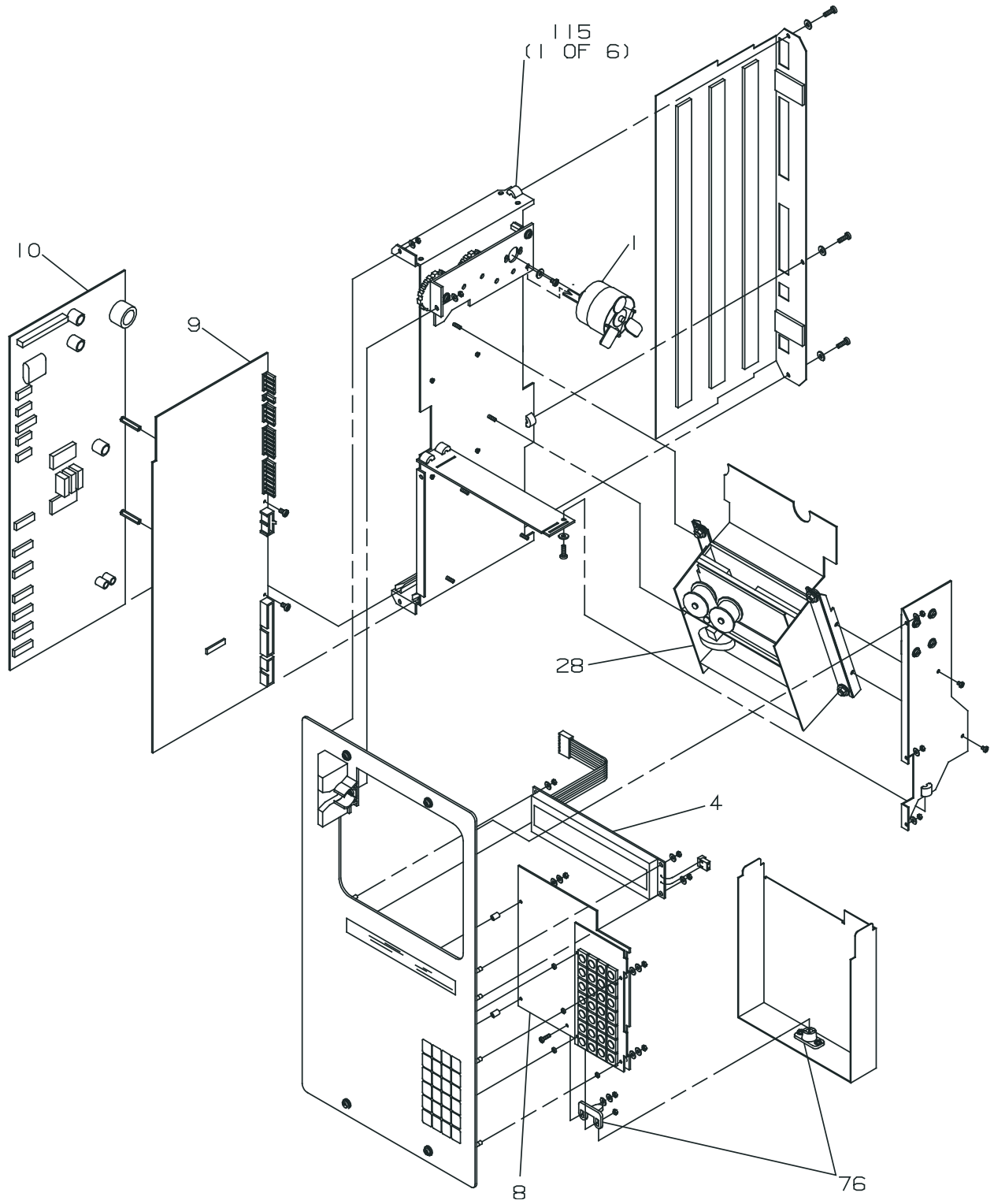

Table A-1 Replacement Parts List

No.	Part Number	Complete Parts Description
1	60-3214-139	Motor Assy Chart Drive 4200
4	60-3214-093	LCD Module Assy B/L
5	60-3224-070	Case Bottom Sub Assembly
8	60-3214-098	Keyboard PCB Assembly
9	60-3254-024	4250 CPU CBA w/ Software
10	60-3254-014	PCB Assembly 4250 Parameter/CPU
11	60-3214-120	Harness Assy - 12 VDC/Sampler
12	60-3214-122	Harness Assy - Interrogator
13	60-3214-140	Wiring Assy, Rain Gauge/Com 1
14	60-3214-125	Harness Assy - Parameter
15	60-3254-017	Harness Assy - Area/Velocity
16	60-3234-022	Supply Spool Assembly
17	60-3234-023	Reroll Spool Assembly
18	60-1874-024	Desiccant Cartridge Assy
28	60-3213-098	Printer Mod
37	60-3213-229	Spool End Cap
39	60-3213-255	Wall Mount
40	60-3213-259	Window
41	60-9003-031	Connector Hole Plug
42	60-3233-099	Hinge Pin
43	60-3233-106	Desiccant Can Holder
44	60-3233-115	Connector Clip - .688 Dia.
45	60-3233-116	Connector Clip - .813 Dia
46	60-3233-117	Connector Clip - .938 Dia
47	60-3253-040	Conn. Clip - .938 Dia- Narrow
48	60-3223-009	Bulkhead Nut
49	60-3223-010	Bulkhead Fitting
51	60-3113-034	Latch Pin
54	60-3233-139	External Desiccant Tube
*60	60-3253-022	Case Top Label
61	60-3213-060	Printer Label
62	60-3253-023	Connector Label
63	68-4250-007	Replacement Door
64	60-3213-260	Window Gasket
65	60-3213-261	Door Gasket

Table A-1 Replacement Parts List (Continued)

No.	Part Number	Complete Parts Description
66	202-4001-14	O-Ring Silicone #114 0.61ID × 0.1 W
67	202-4001-18	O-Ring Silicone #118 0.86 ID × 0.1 W
68	202-4001-20	O-Ring Silicone #120 0.99 ID × 0.1 W
69	60-3214-141	Case Latch Assy
75	109-0605-03	Draw Latch Assy - Small
76	109-0609-00	Cabinet Catch Nylatch Model 135
77	142-2001-00	Component Holder $\frac{3}{4}$ " × 1 $\frac{1}{4}$ "
78	142-2003-00	Component Clip $\frac{3}{4}$ "
79	149-1000-00	Amp Dust Cover 9760-10
80	149-1001-00	Amp Dust Cover MS9760-14
81	149-1001-01	Amp Dust Cover 9760-16
85	202-1000-14	O-Ring #014
88	209-0166-65	Elbow Nylon $\frac{1}{8}$ " NPT to $\frac{1}{4}$ " ID
115	239-0416-32	Sheet Edge Fastener #6-32
116	231-0197-04	SST MS 10-32 × $\frac{1}{4}$ " PH Self Seal
118	60-1704-017	Strap Assy
119	099-0012-00	Dri-Can Desiccant Canister
* Not Shown		

A.2 Accessory/Options Parts List

4250 Flow Meter, Basic Unit, 68-4250-001

Includes:

Area Velocity Sensor, 10' range (25' cable).....	60-3254-001
4250 Flow Meter.....	60-3254-009
Accessory Package.....	60-3254-011
Instruction Manual.....	60-3254-012
Pocket Guide.....	60-3253-020
Caution Tag.....	60-3003-256
Dri-Can Desiccant.....	099-0012-00
Flow Data Handbook.....	60-3003-041

4250 Accessories

Area Velocity Sensor, 10' Range (25' cable).....	60-3254-001
Area Velocity Sensor, 30' Range (50' cable).....	60-3254-003
Area Velocity Sensor, Low Profile (25' cable).....	60-3254-021
25' Extension Cable for the Area Velocity Probe.....	60-3254-005
Flow Meter to Sampler Connect Cable.....	60-3004-107
Interrogator Cable, 9 pin.....	60-2544-044
Interrogator Cable, 25 pin.....	60-2544-040
Standard Y Cable for Isco Samplers.....	60-3704-081
Special Y Cable without diodes.....	60-5314-278
Reference Port Tubing 10' × 1/4" ID Vinyl (provides an extension to the desiccant tube) ...	60-2703-111
Reference Port Tubing 25' × 1/4" ID Vinyl.....	60-2703-112
Compression Bushing (for non-conduit wiring to Quick-Disconnect Box, .37"-.44" dia. cable).....	209-0076-06
Chart Roller.....	60-3004-156
Printer ribbon, black.....	250-0200-00
Plotter paper roll, 58 ft.....	60-2313-019
Spreader Bar.....	60-3004-110

Optional Equipment

High-Low Alarm Relay Box.....	60-3404-028
4-20 mA Output Interface.....	60-1784-039
674 Rain Gauge (0.01").....	60-3284-001
674 Metric Rain Gauge (0.1 mm).....	60-3280-001
Area Velocity Quick-Disconnect Box.....	60-3254-004
Type 'E' Interface.....	60-1784-024
Flowlink Software.....	68-2540-200

(Call factory for additional information)

pH Probe and Model 201 pH Module (25 ft. cable standard).....	68-4200-002
---	-------------

(Includes probe, built-in temperature sensor)

pH Probe only	60-9004-126
D.O. Probe only	472-0000-00
D.O. Membrane Kit	479-0020-02

(Includes 30, 0.002" membranes, electrolyte, sanding tool, and disks)

O-Ring Kit for D. O. Probe	479-0020-00
Temperature Probe only.....	60-3214-130
YSI 600 Sonde with pH, D.O., conductivity, temperature sensors, and 25' cable.....	68-0600-110

Note: Item 68-0600-110 includes a YSI-to-Isco 4200/6700 adapter cable, calibration/transport cup, 1# stainless steel nose weight, and YSI instruction manual. Many other configurations of the YSI 600 Sonde are available **without** either the pH and/or D.O. sensors, or supplied with 50, 100, or 200' cables. Also available is a **low ionic strength pH sensor** for use in streams with very low conductivity (10µmhos/cm or less). Call the factory for more information.

D.O. Sensor Maintenance Supplies

D.O. Probe membrane and electrolyte kit (30 membranes, 30 mL KCl soln., 2 O-rings).....	60-0603-205
D.O. Probe reconditioning kit (Instructions and sanding disks).....	60-0603-206

Miscellaneous – for use with the YSI Sonde

YSI 600 Instruction Manual	60-0603-218
YSI 600 to Isco 4200/6700 Adapter Cable.....	60-0604-001
YSI 600 and Isco 674 Rain Gauge Y-Connect Cable.....	60-0604-002

(This cable allows use of the YSI 600 Sonde and the Isco 674 Rain Gauge at the same time.)

Use the following with Isco Mounting Rings in Round Pipe Installations

Probe Carrier for Temperature probe	60-3204-010
Probe Carrier for pH probe with internal temperature sensor.....	60-3208-001
Probe Carrier for D.O. probe and separate Temperature probe	60-3204-006
Probe Extension (for mounting probes upstream in small pipes).....	68-3200-012
Probe Carrier for Low-Profile Area Velocity Sensor.....	60-3204-029

Spring Rings

Probe Mounting Ring for 6" pipe	68-3200-007
Probe Mounting Ring for 8" pipe	68-3200-008
Probe Mounting Ring for 10" pipe	68-3200-009
Probe Mounting Ring for 12" pipe	68-3200-010
Probe Mounting Ring for 15" pipe	68-3200-011

Universal Mounting Ring (Scissors Ring) (for Pipes 16" diameter and larger)

Base Section (with tabs for mounting up to five probes).....	60-3004-171
Scissors Assembly.....	60-3004-170
Extension 1 (9.0")	60-3004-172
Extension 2 (21.5")	60-3004-173
Extension 3 (31.5")	60-3004-174
Extension 4 (41.5")	60-3004-175

Scissors Ring Assemblies will require a base and scissors section for all sizes. Sizes from 21" to 80" will also require two or more extension sections.

4250 Flow Meter

Appendix B Programming Worksheets

Use this form to make a hard copy of the program you use in your 4250. Most program steps can be completed in the shop without the flow meter being installed or at the job site. However, please note the following:

- Do not attempt to fill out this sheet without first studying the manual, especially Section 2. This section describes the program in detail and offers reasons you might choose one option over another. This is particularly so for those using the flow meter for the first time. Keep this chart as a record. For steps where a space is not provided on the sheet, underline or circle your choices.
- Some of the menus shown on this sheet may not appear on your flow meter. The reason is that you must make choices from the first step forward that will prevent you from choosing other options later on. Options can appear at several points of the program. However, menus pertaining to the options not chosen early on will not appear later. An example is the alarm dial-out feature. This step requires your flow meter to have the optional modem. If you do not have the modem, no menus concerning dialout will appear.
- If, after filling out this chart, you cannot make some menus appear that you need, recheck your early steps to see that you have not accidentally locked yourself out of a path by an incorrect early selection.
- If you only need to program the flow meter once, you can write on this sheet. If you are doing temporary surveys, or expect the program to change, make copies of these sheets and write on the copies.

B.1 Setup

1. Select Option: Program, Setup. *First, choose Setup and work through the following menus.*
2. Year/ Month/ Day/ Hour/ Min _____
3. Site I.D. _____ (*Any three-digit number*)
4. Measurement Setup: Level Reading Interval, Velocity Reading, Minimum Depth, Zero Level Offset, Zero Flow on Error, D.O./pH Reading Interval, YSI 600 Reading Interval
5. Level Reading Interval: Continuous, 15 Sec, 30 Sec, 1 Min, 2 Min, 5 Min _____
6. Velocity Reading Interval: Continuous, 2 Min, 5 Min, 15 Min, 30 Min _____
7. Minimum Depth for Velocity Measurement: 2 IN / 50MM, 3 IN / 75MM, 4 IN / 100MM _____

8. Zero Level Offset = Feet (or Meters)_____
9. Zero Flow on Error? Yes No
10. D.O./pH Reading Interval: Continuous, 15 Sec, 30 Sec, 1Min, 2 Min, 5 Min_____
11. YSI 600 Reading Interval: Continuous, 15 Sec, 30 Sec, 1 Min, 2 Min, 5 Min_____
12. For reference only after installation, copy the values shown on the flow meter: Signal Strength_____ % Spectrum Strength_____ %
13. Velocity Enable/Alarm: Hysteresis _____ Ft/S (or Meters /Second)
14. Level Enable/Alarm: Hysteresis _____ Feet (Or Meters)
15. Flow Rate Enable/Alarm Hysteresis _____ Units_____
16. Temperature Enable/Alarm Hysteresis _____ Deg. F (C)
17. pH Enable/Alarm Hysteresis _____ pH units.
18. D.O. Enable/Alarm Hysteresis _____ ppm.
19. YSI-pH Enable/Alarm Hysteresis _____ pH units.
20. YSI-D.O. Enable/Alarm Hysteresis _____ ppm/mg./L
21. YSI-Conductivity Enable /Alarm Hysteresis_____ mS/cm
22. YSI-Temperature Enable/Alarm Hysteresis_____ Deg.
23. Optional Outputs: 4-20 Ma Output, Serial Output, Alarm Box, Mechanical Totalizer
24. Report Setup, Report A: Flow, D.O./pH, YSI 600, Sample History, Flow Meter History
25. Level In Report: Yes No
26. Velocity In Report: Yes No
27. Flow Rate In Report: Yes No
28. Rainfall In Report: Yes No
29. pH or D.O. In Report: Yes No
30. Temperature In Report: Yes No
31. YSI 600 Data in Report: Yes No
32. Sample History In Report: Yes No
33. Flow Meter History In Report: Yes No
34. Report Setup, Report B: Flow, D.O./pH, YSI 600, Sample History, Flow Meter History
35. Level In Report: Yes No
36. Velocity In Report: Yes No
37. Flow Rate In Report: Yes No
38. Rainfall In Report: Yes No
39. pH or D.O. In Report: Yes No
40. Temperature In Report: Yes No
41. YSI 600 Data in Report: Yes No

42. Sample History In Report: Yes No
43. Setup Options: Status, Report Setup, LCD Backlight
44. LCD Backlight Mode: Time-out, Continuous, Off
45. Language: English, French, German, Spanish
46. Program Lock: On, Off
47. Select Option: Program, Setup. *This time, select Program and do the following* (Program Section)
48. Units Of Level Measure: Ft., In, M, mm, Not Measured
49. Flow Rate Units of Measure: GPS, GPM, GPH, MGD, CFS, CFM, CFH, CFD, LPS, M3S, M3M, M3H, M3D, AFD
50. Totalized Volume Units: GAL, MGAL, CF, L, M3, AF
51. Rain Gauge: Inches, MM, Not Measured
52. pH Units Of Measure: pH, Not Measured
53. D. O. Units: MG/L, PPM, Not Measured
54. Temperature Units: Deg F, Deg. C, (Not Measured)
55. YSI-pH Units Of Measure: pH, Not Measured
56. YSI-D.O. Units: MG/L, PPM, Not Measured
57. YSI-Conductivity Parameter: Specific Conductivity, Salinity, Conductivity, T.D. S.
_____Units_____Coeff._____
58. YSI-Temperature: Deg F, Deg. C, (Not Measured)

B.2 Flow Conversion: Area Velocity

1. Flow Calculation: Area Velocity
2. Area Velocity Calculation: Velocity, Data Points
3. Area Velocity - Channel Shape: Round Pipe, U-Channel, Rectangular, Trapezoidal_____
4. Velocity Round Pipe: Diameter = _____Ft. (or meters)
5. Velocity U-Channel: Width = _____Ft. (or meters)
6. Velocity Rectangular: Width = _____Ft. (or meters)
7. Velocity Trapezoidal: Top Width = _____Ft. (or meters)
8. Velocity Trapezoidal: Bottom Width = _____Ft. (or meters)
9. Area Velocity Calculation: Velocity / Data Points_____
10. Data Point Set: One, Two, Three, Four, (None)_____
(Velocity data points may be either level-to-flow or level-to-area.)
11. Level Units For Data Point Entry: Ft, In, M, MM_____
12. Flow Rate Units: GPM, GPS, MGD, CFS, CFM, M3S, M3H, M3D, LPS, CFD, GPH, AFD, CFH, CFM, M3M_____
13. Set_____ (1-4): (0) Points Entered: Add Point, (units)_____
14. Set 1 Data Point 1: Enter: ____ (level units) ____ (units of volume)

the YSI 600 Sonde. Steps 3, 4, and 5 can be used for both 2 and 3-point pH calibrations.

3. Rinse Probe And Place In 4.0 pH Solution: Press Enter When Stable ____ pH (job site only)
4. Rinse Probe And Place In 7.0 pH Solution: Press Enter When Stable ____ pH (job site only)
5. Rinse Probe And Place In 10.0 pH Solution: Press Enter When Stable ____ pH (job site only)
6. (YSI 600 D.O. Calibration only): D.O. Standard, Absolute Barometric Pressure, Altitude
7. Altitude Units Of Measure: Ft., M (D.O. probe only)____ (job site only)
8. (D.O. only) Enter Altitude: Altitude = _____ Feet (or meters, at job site only)
9. Wrap D.O. Probe In Moist Cloth: Press Enter When Stable: ____ MG/L (at job site only)
10. Conductivity Calibration Units: Ms/cm, Ppt _____
11. Place Probe In _____Ms/cm. (or ppt) Press Enter When Stable: _____Ms/cm (at job site only)
12. YSI 600 Dissolved Oxygen Calibration: D.O. Standard, Absolute Barometric Pressure, Altitude

B.5 Reset Totalizer

1. Reset Totalizer: Yes No
2. Enable Totalizer _____CF (or other units) _____
3. Reset Sampler Enable Totalizer: Yes No

B.6 Sampler Pacing

1. Sampler Pacing: Disable, (Volume), (Flowlink), Conditional
2. Sampler Pacing: Enter Pacing Volume ____ CF
3. Condition: Level, Flow Rate, Rainfall, D.O., pH, Temperature, YSI pH, YSI D.O., YSI Conductivity, YSI Temperature
4. Condition: Greater Than, Less Than, Rate Of Change
5. Select Operator: Done, Or, And
6. Condition True Pacing Interval: Pace Every ____ Minutes.
7. Condition False Pacing Interval: Pace Every ____ Minutes.

B.7 Sampler Enable

1. Sampler Enable Mode: Disable, Enable, Conditional, (Storm), (Flowlink)
2. Level: Greater Than ____ Feet (or meters)
3. Rainfall Amount: ____ Inches (other units)
4. Rainfall Time Period: 15 Min, 30 Min, 1 Hr, 2 Hr, 4 Hr, 6 Hr, 8 Hr, 12 Hr, 24 Hr, 48 Hr, 72 Hr
5. Time Since Last Rainfall: Days: _____ (enter 1 to 7)
6. Condition: Level, Flow Rate, D.O., pH, Temperature, Rainfall, YSI pH, YSI D.O., YSI Conductivity, YSI Temperature

7. Level: Greater Than, Less Than, Rate Of Change
8. Level: Greater Than ____ Feet (or meters)
9. Select Operator: Done, Or, And
10. Flow Rate: Greater Than, Less Than, Rate Of Change
11. When Enable Condition Is No Longer Met: Disable Sampler, Keep Enabled
12. Enable Currently Latched, Reset: No, Yes
13. Printer On/off With Enable: Yes No

B.8 Alarm Dialout Mode

You must have a modem installed in the flow meter for any of these menus to appear.

1. Alarm Dialout: Disable, Conditional, Storm, Flowlink
2. Level: Greater Than ____ Feet.
3. Rainfall Amount: ____ Inches (other units)
4. Rainfall Time Period: 15 Min, 30 Min, 1 Hr, 2 Hr, 4 Hr, 6 Hr, 8 Hr, 12 Hr, 24 Hr, 48 Hr, 72 Hr
5. Time Since Last Rainfall: Days: _____ (allowable 1-7)
6. Condition: Level, Flow Rate, D.O., pH, Temperature, Rainfall, YSI pH, YSI DO, YSI Conductivity, YSI Temperature
7. Condition: Greater Than, Less Than, Rate Of Change
8. Select Operator: Done, Or, And
9. Alarm Dial-out Numbers: Done, Num. 1, Num. 2, Num. 3, Num. 4, Num. 5
10. First Phone Number: _____
11. Second Phone Number: _____
12. Third Phone Number: _____
13. Fourth Phone Number: _____
14. Fifth Phone Number: _____
15. Delay Between Dialouts: _____ Minutes
16. Callback To Disable Alarm: Yes No

B.9 Printer

1. Enter Printer Speed: Off, 1"/hr, 2"/hr, 4"/hr
2. Input For Printer Line A: None, Level, Velocity, Flow Rate, pH, D.O., Temp, YSI pH, YSI D.O., YSI Cond., YSI Temp.
3. Printer Line A Bottom Scale: ____ (units)
4. Printer Line A Full Scale: ____ (units)
5. Input For Printer Line B: None, Level, Velocity, Flow Rate, pH, D.O., Temp, YSI pH, YSI D.O., YSI Cond., YSI Temp.
6. Input For Printer Line C: None, Level, Velocity, Flow Rate, pH, D.O., Temp, YSI pH, YSI D.O., YSI Cond., YSI Temp.
7. Plot Rainfall On Chart?: No, Yes

B.10 Reports/History

1. Report Generator A: On, Off, (Print)
2. Report A Duration To Be In: Hours, Days, Months

4250 Flow Meter

Appendix C General Safety Procedures

In field installations of 4250 Flow Meters and associated equipment, the safety of the personnel involved should be the foremost consideration. The following sections provide safety procedures for working in and around manholes and sewers. The first section offers general safety advice. The second section deals with the special problem of hazardous gases found in sewers.

WARNING

The 4250 Flow Meter has not been approved for use in hazardous locations as defined by the National Electrical Code.

CAUTION

Before any flow meter is installed, the proper safety precautions must be taken. The following discussions of safety procedures are only general guidelines. Each situation in which you install a flow meter varies. You must take into account the individual circumstances you are in. Additional safety considerations, other than those discussed here, may be required.

C.1 Practical Safety Precautions

The following procedures are those used by Black & Veatch, a respected consulting firm, and are published here by permission.

“Field personnel must keep safety uppermost in their minds at all times. When working above ground, rules of common sense and safety prevail. However, when entering manholes, strict safety procedures must be observed. Failure to do so could jeopardize not only your own life, but also the lives of other crew members.

“1. **Hazards.** There are many hazards connected with entering manholes. Some of the most common hazards are:

“**Adverse Atmosphere.** The manhole may contain flammable or poisonous gases or the atmosphere may be deficient in oxygen. Forced ventilation may be necessary.

“**Deteriorated Rungs.** Manhole steps may be corroded and not strong enough to support a man. It may be difficult to inspect the rungs because of poor lighting.

“**Traffic.** Whenever manholes are located in the traveled way, barricades and warning devices are essential to direct traffic away from an open manhole.

“**Falling Object.** Items placed near the manhole opening may fall and injure a worker in the manhole.

“**Sharp Edges.** Sharp edges of items in or near a manhole may cause cuts or bruises.

“Lifting Injuries. Unless proper tools are used to remove manhole covers, back injuries or injuries to hands or feet may result.

“2. Planning. Advance planning should include arrangements for test equipment, tools, ventilating equipment, protective clothing, traffic warning devices, ladders, safety harness, and adequate number of personnel. Hasty actions may result in serious injuries. Time spent in the manhole should be kept to a minimum.

“3. Adverse Atmosphere. [Refer to Table C-1, Hazardous Gases, at the end of this appendix.] Before workers enter a manhole, tests should be made for explosive atmosphere, presence of hydrogen sulfide, and oxygen deficiency. Combustible or toxic vapors may be heavier than air, so the tests on the atmosphere must be run at least $\frac{3}{4}$ of the way down the manhole.

“Whenever adverse atmosphere is encountered, forced ventilation must be used to create safe conditions. After the ventilating equipment has been operated for a few minutes, the atmosphere in the manhole should be retested before anyone enters the manhole.

“When explosive conditions are encountered, the ventilating blower should be placed upwind to prevent igniting any gas that is emerging from the opening. When a gasoline engine blower is used, it must be located so that exhaust fumes cannot enter the manhole.

“If testing equipment is not available, the manhole should be assumed to contain an unsafe atmosphere and forced ventilation must be provided. It should never be assumed that a manhole is safe just because there is no odor or the manhole has been entered previously.

“4. Entering Manholes. Since the top of the manhole is usually flush with the surrounding surface, there may not be anything for the person who is entering the manhole to grab on to steady himself. Persons who are entering manholes should not be permitted to carry anything in their hands as they enter the manhole, to ensure that their hands will be free to hold on or grab if they slip. A good method for entering a manhole is to sit on the surface facing the manhole steps or ladder, with the feet in the hole and the arms straddling the opening for support. As the body slides forward and downward, the feet can engage a rung, and the back can rest against the opposite side of the opening. If there is any doubt about the soundness of the manhole steps, a portable ladder should be used.

“A person should never enter a manhole unless he is wearing personal safety equipment, including a safety harness and a hard hat. Two persons should be stationed at the surface continuously while anyone is working inside a manhole, to lift him out if he is overcome or injured. One man cannot lift an unconscious man out of a manhole. The persons stationed at the surface should also function as guards to keep people and vehicles away from

the manhole opening. To avoid a serious injury, a person should not be lifted out of a manhole by his arm unless it is a dire emergency.

“When more than one person must enter a manhole, the first person should reach the bottom and step off the ladder before the next one starts down. When two men climb at the same time, the upper one can cause the lower one to fall by slipping or stepping on his fingers.

“5. **Traffic Protection.** In addition to traffic cones, markers, warning signs, and barricades, a vehicle or a heavy piece of equipment should be placed between the working area and oncoming traffic. Flashing warning signals should be used to alert drivers and pedestrians. Orange safety vests should be worn by personnel stationed at the surface when the manhole is located in a vehicular traffic area.

“6. **Falling Object.** All loose items should be kept away from the manhole opening. This applies to hand tools as well as stones, gravel and other objects.

“7. **Removing the Covers.** Manhole covers should be removed with a properly designed hook. Use of a pick ax, screwdriver, or small pry bar may result in injury. A suitable tool can be made from $\frac{3}{4}$ -inch round or hex stock. Two inches of one end should be bent at a right angle and the other end should be formed into a D-handle wide enough to accommodate both hands. Even with this tool, care must be exercised to prevent the cover from being dropped on the toes. The 2-inch projection should be inserted into one of the holes in the cover, the handle grasped with both hands, and the cover lifted by straightening the legs which have been slightly bent at the knees.

“8. **Other Precautions.** Other precautions which should be taken when entering a manhole are:

- Wear a hard hat.
- Wear coveralls or removable outer garment that can be readily removed when the work is completed.
- Wear boots or nonsparking safety shoes.
- Wear rubberized or waterproof gloves.
- Wear a safety harness with a stout rope attached.
- Do not smoke.
- Avoid touching yourself above the collar until you have cleaned your hands.

“9. **Emergencies.** Every member of the crew should be instructed on procedures to be followed in cases of an emergency. It is the duty of each crew chief to have a list of emergency phone numbers, including the nearest hospital and ambulance service, police precinct, fire station, and rescue or general emergency number.

“10. **Field Equipment.** The following equipment will be available for use:

Blowers	Gloves	Traffic cones
Breathing apparatus	Hard Hats	Coveralls
Harnesses	First aid kits	Manhole irons
Emergency flashers	Pick axes	Flashlights
Rain slickers	Mirrors	Ropes
Gas detectors	Safety vests	Gas masks
Waders”		

C.2 Lethal Atmospheres in Sewers

The following is an article written by Dr. Richard D. Pomeroy, and published in the October 1980 issue of *Deeds & Data* of the WPCF. Dr. Pomeroy is particularly well known for his studies, over a period of nearly 50 years, in the field of the control of hydrogen sulfide and other odors in sewers and treatment plants. He has personally worked in a great many functioning sewers. In the earlier years he did so, he admits, with little knowledge of the grave hazards to which he exposed himself.

“It is gratifying that the subject of hazards to people working in sewers is receiving much more attention than in past years, and good safety procedures are prescribed in various publications on this subject. It is essential that people know and use correct procedures.

“It is less important to know just what the hazardous components of sewer atmospheres are, as safety precautions should in general be broadly applicable, but there should be a reasonable understanding of this subject. It is disturbing to see statements in print that do not reflect true conditions.

“One of the most common errors is the assumption that people have died from a lack of oxygen. The human body is able to function very well with substantially reduced oxygen concentrations. No one worries about going to Santa Fe, New Mexico, (elev. 2,100 meters), where the partial pressure of oxygen is equal to 16.2% (a normal atmosphere is about 21%) oxygen. When first going there, a person may experience a little ‘shortness of breath’ following exercise. People in good health are not afraid to drive over the high passes in the Rocky Mountains. At Loveland Pass, oxygen pressure is 13.2% of a normal atmosphere. At the top of Mt. Whitney, oxygen is equal to 12.2%. Many hikers go there, and to higher peaks as well. After adequate acclimation, they may climb to the top of Mt. Everest, where oxygen is equal to only 6.7%.

“The lowest oxygen concentrations that I have observed in a sewer atmosphere was 13 percent. It was in a sealed chamber, near sea level, upstream from an inverted siphon on a metropolitan trunk. A man would be foolish to enter the chamber. Without ventilation, he might die, but not from lack of oxygen.

“It seems unlikely that anyone has ever died in a sewer from suffocation, that is, a lack of oxygen. Deaths have often been attributed to ‘asphyxiation.’ This is a word which, according to the dictionary, is used to mean death from an atmosphere that does not support life. The word has sometimes been misinterpreted as meaning suffocation, which is only one kind of asphyxiation.

“In nearly all cases of death in sewers, the real killer is hydrogen sulfide. It is important that this fact be recognized. Many cities diligently test for explosive gases, which is very important, and they may measure the oxygen concentration which usually is unimportant, but they rarely measure H₂S. Death has occurred where it is unlikely that there was any measurable reduction in the oxygen concentration. Waste water containing 2 mg per liter of dissolved sulfide, and at a pH of 7.0, can produce, in a chamber with high turbulence, a concentration of 300 PPM H₂S, in the air. This is considered to be a lethal concentration. Many people have died from H₂S, not only in sewers and industries, but also from swamps and from hot springs. In one resort area, at least five persons died from H₂S poisoning before the people were ready to admit that H₂S is not a therapeutic agent. Hardly a year passes in the U.S. without a sewer fatality from H₂S as well as deaths elsewhere in the world.

“The presence of H₂S in a sewer atmosphere is easily determined. A bellows-and-ampoule type of tester is very satisfactory for the purpose, even though it is only crudely quantitative. When using a tester of this type, do not bring the air to the ampoule by way of a tube, as this may change the H₂S concentration. Hang the ampoule in the air to be tested, with a suction tube to the bulb or bellows.

“Lead acetate paper is very useful as a qualitative indicator. It cannot be used to estimate the amount of sulfide, but it will quickly turn black in an atmosphere containing only a tenth of a lethal concentration.

“Electrodes or other similar electrical indicating devices for H₂S in air have been marketed. Some of them are known to be unreliable, and we know of none that have proved dependable. Do not use one unless you check it at frequent intervals against air containing known H₂S concentrations. A supposed safety device that is unreliable is worse than none at all.

“Remember that the nose fails, too, when it comes to sensing dangerous concentrations of H₂S.

“Various other toxic gases have been mentioned in some publications. It is unlikely that any person has been asphyxiated in a sewer by any of those other gases, except possibly chlorine. The vapor of gasoline and other hydrocarbons is sometimes present in amounts that could cause discomfort and illness, but under that condition, the explosion hazard would be far more serious. The explosimeter tests, as well as the sense of smell, would warn of the danger. Pipelines in chemical plants might contain any

number of harmful vapors. They, too, are sensed by smell and explosimeter tests if they get into the public sewer. Such occurrences are rare.

“The attempt to instill a sense of urgency about real hazards is diluted if a man is told to give attention to a long list of things that in fact are irrelevant.

“Be very careful to avoid high H₂S concentrations, flammable atmospheres, and hazards of physical injuries. Remember that much H₂S may be released by the stirring up of sludge in the bottom of a structure. Obey your senses in respect to irritating gases, such as chlorine (unconsciousness comes suddenly from breathing too much). Be cautious about strange odors. Do not determine percent oxygen in the air. There is a danger that the result will influence a man’s thinking about the seriousness of the real hazards. Most important, use ample ventilation, and do not enter a potentially hazardous structure except in a good safety harness with two men at the top who can lift you out.”

C.3 Hazardous Gases

The following table contains information on the properties of hazardous gases.

Table C-1 Hazardous Gases										
Gas	Chemical Formula	Common Properties	Specific Gravity or Vapor Density Air =1	Physiological Effect	Max Safe 60 Min. Exposure ppm	Max. Safe 8 Hour Exposure ppm	Explosive Range (% by vol. in air) Limits lower/upper	Likely Location of Highest Concentration	Most Common Sources	Simplest and Cheapest Safe Method of Testing
Ammonia	NH ₃	Irritant and poisonous. Colorless with characteristic odor.	0.60	Causes throat and eye irritation at 0.05%, coughing at 0.17%. Short exposure at 0.5% to 1% fatal.	300 to 500	85	16 25	Near top. Concentrates in closed upper spaces	Sewers, chemical feed rooms.	Detectable odor at low concentrations
Benzene	C ₆ H ₆	Irritant, colorless anesthetic	2.77	Slight symptoms after several hours exposure at 0.16% to 0.32%. 2% rapidly fatal.	3,000 to 5,000	25	1.3 7.1	At bottom.	Industrial wastes, varnish, solvents.	Combustible gas indicator
Carbon Bisulfide	CS ₂	Nearly odorless when pure, colorless, anesthetic. Poisonous.	2.64	Very poisonous, irritating, vomiting, convulsions, psychic disturbance.	—	15	1.3 44.0	At bottom	An insecticide	Combustible gas indicator
Carbon Dioxide	CO ₂	Asphyxiant, Colorless, odorless. When breathed in large quantities, may cause acid taste. Non-flammable. Not generally present in dangerous amounts unless an oxygen deficiency exists.	1.53	Cannot be endured at 10% more than a few minutes, even if subject is at rest and oxygen content is normal. Acts on respiratory nerves.	40,000 to 60,000	5,000	— —	At bottom; when heated may stratify at points above bottom.	Products of combustion, sewer gas, sludge. Also issues from carbonaceous strata.	Oxygen deficiency indicator

Table C-1 Hazardous Gases (Continued)

Gas	Chemical Formula	Common Properties	Specific Gravity or Vapor Density Air = 1	Physiological Effect	Max Safe 60 Min. Exposure ppm	Max. Safe 8 Hour Exposure ppm	Explosive Range (% by vol. in air) Limits lower/upper	Likely Location of Highest Concentration	Most Common Sources	Simplest and Cheapest Safe Method of Testing
Carbon Monoxide	CO	Chemical asphyxiant. Colorless, odorless, tasteless. Flammable. Poisonous.	0.97	Combines with hemoglobin of blood. Unconsciousness in 30 min. at 0.2% to 0.25%. Fatal in 4 hours at 0.1%. Headache in few hours at 0.02%.	400	50	12.5 74.0	Near top, especially if present with illuminating gas.	Manufactured gas, flue gas, products of combustion, motor exhausts. Fires of almost any kind.	CO ampoules.
Carbon Tetra-Chloride	CCl ₄	Heavy, ethereal odor.	5.3	Intestinal upset, loss of consciousness, possible renal damage, respiratory failure.	1,000 to 1,500	100	— —	At bottom.	Industrial wastes, solvent, cleaning	Detectable odor at low concentrations.
Chlorine	Cl ₂	Irritant. Yellow-green color. Choking odor detectable in very low concentrations. Non-flammable.	2.49	Irritates respiratory tract. Kills most animals in a very short time at 0.1%.	4	1	— —	At bottom.	Chlorine cylinder and feed line leaks.	Detectable odor at low concentrations.
Formaldehyde	CH ₂ O	Colorless, pungent suffocating odor.	1.07	Irritating to the nose.	—	10	7.0 73.0	Near bottom.	Incomplete combustion of organics. Common air pollutant, fungicide.	Detectable odor.
Gasoline	C ₅ H ₁₂ to C ₉ H ₂₀	Volatile solvent. Colorless. Odor noticeable at 0.03%. Flammable.	3.0 to 4.0	Anesthetic effects when inhaled. Rapidly fatal at 2.4%. Dangerous for short exposure at 1.1 to 2.2%.	4,000 to 7,000	1,000	1.3 6.0	At bottom.	Service stations, garages, storage tanks, houses.	1. Combustible gas indicator. 2. Oxygen deficiency indicator.**
Hydrogen	H ₂	Simple asphyxiant. Colorless, odorless, tasteless. Flammable	0.07	Acts mechanically to deprive tissues of oxygen. Does not support life.	—	—	4.0 74.0	At top.	Manufactured gas, sludge digestion tank gas, electrolysis of water. Rarely from rock strata.	Combustible gas indicator.
Hydrogen Cyanide	HCN	Faint odor of bitter almonds. Colorless gas	0.93	Slight symptoms appear upon exposure to 0.002% to 0.004%. 0.3% rapidly fatal.	—	10	6.0 40.0	Near top.	Insecticide and rodenticide.	Detector tube
Gas	Chemical Formula	Common Properties	Specific Gravity or Vapor Density Air = 1	Physiological Effect*	Max Safe 60 Min. Exposure ppm	Max. Safe 8 Hour Exposure ppm	Explosive Range (% by vol. in air.) Limits lower/upper	Likely Location of Highest Concentration	Most Common Sources	Simplest and Cheapest Safe Method of Testing

Table C-1 Hazardous Gases (Continued)

Gas	Chemical Formula	Common Properties	Specific Gravity or Vapor Density Air = 1	Physiological Effect	Max Safe 60 Min. Exposure ppm	Max. Safe 8 Hour Exposure ppm	Explosive Range (% by vol. in air) Limits lower/upper	Likely Location of Highest Concentration	Most Common Sources	Simplest and Cheapest Safe Method of Testing
Hydrogen Sulfide	H ₂ S	Irritant and poisonous volatile compound. Rotten egg odor in small concentrations. Exposure for 2 to 15 min. at 0.01% impairs sense of smell. Odor not evident at high concentrations. Colorless. Flammable.	1.19	Impairs sense of smell, rapidly as concentration increases. Death in few minutes at 0.2%. Exposure to 0.07 to 0.1% rapidly causes acute poisoning. Paralyzes respiratory center.	200 to 300	20	4.3 45.0	Near bottom, but may be above bottom if air is heated and highly humid.	Coal gas, petroleum, sewer gas. Fumes from blasting under some conditions. Sludge gas.	1. H ₂ S Ampoule. 2. 5% by weight lead acetate solution.
Methane	CH ₄	Simple asphyxiant. Colorless, odorless, tasteless, flammable.	0.55	Acts mechanically to deprive tissues of oxygen. Does not support life.	Probably no limit, provided oxygen percent-age is sufficient for life.	—	5.0 15.0	At top, increasing to certain depth.	Natural gas, sludge gas, manufactured gas, sewer gas. Strata of sedimentary origin. In swamps or marshes.	1. Combustible gas indicator 2. Oxygen deficiency indicator.
Nitrogen	N ₂	Simple asphyxiant. Colorless, tasteless. Non-flammable. Principal constituent of air. (about 79%).	0.97	Physiologically inert.	—	—	— —	Near top, but may be found near bottom.	Sewer gas. sludge gas. Also issues from some rock strata.	Oxygen deficiency indicator.
Nitrogen Oxides	NO	Colorless	1.04	60 to 150 ppm cause irritation and coughing.	50	10	— —	Near bottom.	Industrial wastes. Common air pollutant.	NO ₂ detector tube.
	N ₂ O	Colorless, sweet odor.	1.53	Asphyxiant.						
	NO ₂	Reddish-brown. Irritating odor. Deadly poison	1.58	100 ppm dangerous. 200 ppm fatal.						
Oxygen	O ₂	Colorless, odorless, tasteless. Supports combustion.	1.11	Normal air contains 20.8% of O ₂ . Man can tolerate down to 12%. Minimum safe 8 hour exposure, 14 to 16%. Below 10%, dangerous to life. Below 5 to 7% probably fatal.	—	—	— —	Variable at different levels.	Oxygen depletion from poor ventilation and absorption, or chemical consumption of oxygen.	Oxygen deficiency indicator.
Ozone	O ₃	Irritant and poisonous. Strong electrical odor. Strong oxidizer. Colorless. At 1 ppm, strong sulfur-like odor.	1.66	Max. naturally occurring level is 0.04 ppm. 0.05 ppm causes irritation of eyes and nose. 1 to 10 ppm causes headache, nausea; can cause coma. Symptoms similar to radiation damage.	0.08	0.04	— —	Near bottom.	Where ozone is used for disinfection.	Detectable odor at 0.015 ppm.
Sludge Gas	—***	Mostly a simple asphyxiant. May be practically odorless, tasteless.	Variable	Will not support life.	No data. Would vary widely with composition.		5.3 19.3	Near top of structure.	From digestion of sludge.	See components.

Table C-1 Hazardous Gases (Continued)

Gas	Chemical Formula	Common Properties	Specific Gravity or Vapor Density Air =1	Physiological Effect	Max Safe 60 Min. Exposure ppm	Max. Safe 8 Hour Exposure ppm	Explosive Range (% by vol. in air) Limits lower/upper	Likely Location of Highest Concentration	Most Common Sources	Simplest and Cheapest Safe Method of Testing
Sulfur Dioxide	SO ₂	Colorless, pungent odor. Suffocating, corrosive, poisonous, non-flammable.	2.26	Inflammation of the eyes. 400 to 500 ppm immediately fatal.	50 to 100	10	— —	At bottom, can combine with water to form sulfurous acid.	Industrial waste, combustion, common air pollutant.	Detectable taste and odor at low concentration.
Toluene	C ₅ H ₁₂ to C ₉ H ₂₀	Colorless, benzene-like odor.	3.14	At 200-500 ppm, headache, nausea, bad taste, lassitude.	200	100	1.27 7.0	At bottom.	Solvent.	Combustible gas indicator.
Turpentine	C ₁₀ H ₁₆	Colorless, Characteristic odor.	4.84	Eye irritation. Headache, dizziness, nausea, irritation of the kidneys.	—	100		At bottom.	Solvent, used in paint.	1. Detectable odor at low concentrations. 2. Combustible gas indicator.
Xylene	C ₈ H ₁₀	Colorless, flammable	3.66	Narcotic in high concentrations. less toxic than benzene.	—	100	1.1 7.0	At bottom.	Solvent	Combustible gas indicator.

* Percentages shown represent volume of gas in air.

** For concentration over 0.3%.

***Mostly methane and carbon dioxide with small amounts of hydrogen, nitrogen, hydrogen sulfide, and oxygen; occasionally traces of carbon monoxide.

4250 Flow Meter

Appendix D Material Safety Data Sheets

D.1 Overview

This appendix provides Material Safety Data Sheets for the desiccant used by the 4250 Flow Meter.

Teledyne Isco cannot guarantee the accuracy of the data. Specific questions regarding the use and handling of the products should be directed to the manufacturer listed on the MSDS.

Distributed by: Rainbow Technology Corp.
1.800.637.6047 or 205.733.0333
Product #: 79355

Page 1 of 5



MATERIAL SAFETY DATA SHEET

Effective Date February 14, 2009
MSDS Number M75

Section 1 – Product and Company Information

Product Name: Silica gel, indicating
Product Use: Desiccant, absorbent
Grades: Silica gel indicating
Synonyms: Amorphous silica gel, SiO₂, silicon dioxide (amorphous)
Company: Multisorb Technologies, Inc.
Street Address: 325 Harlem Road
City, State, Zip, Country: Buffalo, NY 14224-1893 USA
Telephone Number: (716) 824 8900 [USA] Monday - Friday (8:00 - 5:00 EDT)
Fax Number: (716) 824 4091 [USA]
Website / E-Mail : multisorb.com

Section 2 – Hazard Identification

Emergency Overview: A blue to pink granular material that poses little or no immediate hazard. This material is not combustible.

Potential Health Effects:

Eyes: Dust and or product may cause eye discomfort and irritation seen as tearing and reddening.

Skin: The product dust may cause drying of the skin. Silica gel may get hot enough to burn skin when it adsorbs moisture rapidly. Use an excess of water to cool the silica gel.

Ingestion: Material is not toxic and will pass through the body normally.

Inhalation: Slight irritation is possible but none is expected.

Medical Effects Generally Aggravated by Exposure: Respiratory ailments.

Chronic Effects/Carcinogenicity: May cause eye, skin and mucous membrane irritation and drying.

Section 3 – Composition / Information on Ingredients

Component Name	CAS Number	% by Weight
Synthetic amorphous silica gel (SiO ₂)	112926-00-8	100
Cobalt Chloride	7646-79-9	.5

While this material is not classified as hazardous under OSHA regulations, this MSDS contains valuable information critical to the safe handling and proper use of this product. This MSDS should be retained and available for employees and other users of this product.

Section 4 – First Aid Measures

Eyes: Rinse eyes well with water while lifting eye lids. If irritation persists, consult a physician.

Skin: Wash affected area with soap and water.

Ingestion: Ingestion is unlikely, this material will pass through the body normally.

Inhalation: Remove the affected person to fresh air and get medical attention if necessary.

Multisorb Technologies, Inc Silica gel, Indicating February 14, 2009 Page 2 of 5
Notes to Physician: Not applicable

Section 5 – Fire Fighting Measures

Flammable Properties: Not flammable
Flash Point: Not applicable **Method:** Not applicable
Flammable Limits: Not flammable
Lower Flammability Limit: Not applicable
Upper Flammability Limit: Not applicable
Auto-ignition Temperature: Not applicable
Hazardous Combustion Products: Not applicable
Extinguishing Media: Use extinguishing media that is appropriate for the surrounding fire. Silica gel is not combustible.
Fire Fighting Instructions: Not combustible
Unusual Fire and Explosion Hazards: None
Explosion Data Not sensitive to static discharge
Not sensitive to mechanical impact.

Section 6 – Accidental Release Measures

Spill: Sweep or vacuum up and place the spilled material in a waste disposal container. Avoid raising dust. Wash with soap and water after handling.

Section 7 – Handling and Storage

Handling: Avoid raising dust and minimize the contact between worker and the material. Practice good hygienic work practices.
Storage: Store in a cool, dry location. Keep in sealed containers away from moisture. The silica gel will readily adsorb moisture.

Section 8 – Exposure Controls/Personal Protection

Engineering Controls: Use exhaust ventilation to keep the airborne concentrations below the exposure limits.
Respiratory Protection: Use NIOSH approved respirator when the air quality levels exceed the TLV's.
Skin Protection: Light cotton gloves will protect against abrasion and drying of the skin.
Eye Protection: Safety glasses.

Exposure Limits

Multisorb Technologies, Inc		Silica gel, Indicating		February 14, 2009		Page 3 of 5	
Component Name	OSHA PEL	ACGIH TLV	Other Recommended Limits				
Silica gel	TWA 20 mppcf (80 mg / m ³ % SiO ₂)	Not Applicable	NIOSH REL TWA 6 mg / m ³ IDLH 3000 mg / m ³				
Cobalt chloride	TWA .1 mg / m ³ (cobalt metal fume & dust)	TWA .02 mg / m ³ (as cobalt)	NIOSH REL TWA .05 mg / m ³ Cobalt metal dust and fume as cobalt IDLH 20 mg / m ³ (as metal dust & fume) (as Co)				

Section 9 – Physical and Chemical Properties

Appearance:	Pink to blue granules	Vapor Density:	Not applicable
Odor:	None	Boiling Point:	4046° F (2230° C)
Physical State:	Solid granule	Melting Point:	3110° F (1710° C)
PH:	Not applicable	Solubility:	Insoluble in water
Vapor Pressure:	Not applicable	Specific Gravity:	2.1
Evaporation Rate	Not applicable	Odor Threshold	Not applicable
Coefficient of water / oil distribution	Not applicable	Auto-ignition Point:	Not applicable
Flammable:	Not applicable	Flammable Limits:	Not applicable
Flash Point:	Not applicable		

Section 10 – Stability and Reactivity

Stability:	Stable
Conditions to avoid:	Moisture and high humidity environments.
Incompatibility:	Water, fluorine, oxygen difluoride, chlorine trifluoride
Hazardous Decomposition Products:	None
Hazardous Polymerization:	Will not occur

Section 11 – Toxicological Information

This product and its components are not listed on the NTP or OSHA Carcinogen lists.

Animal Toxicology	Tests for DOT Hazard classification (Tests Conducted on finely ground silica gel)
	1 - hour LC ₅₀ (rat) > 2 mg / l
	48 - hour oral LD ₅₀ (rat) est. > 31,600 mg / kg
	48 - hour dermal LD ₅₀ (rabbit) est. > 2,000 mg / kg
	Considered an ocular irritant

Multisorb Technologies, Inc Silica gel, Indicating February 14, 2009 Page 4 of 5

Human Toxicology Silica gel is a synthetic amorphous silica not to be confused with crystalline silica. Epidemiological studies indicate low potential for adverse health effects. In the activated form, silica gel acts as a desiccant and can cause a drying irritation of the mucous membranes and skin in cases of severe exposure. Multisorb Technologies Inc. knows of no medical conditions that are abnormally aggravated by exposure to silica gel. The primary route of entry is inhalation of dust.

Section 12 – Ecological Information

Not known to have any adverse effect on the aquatic environment. Silica gel is insoluble and non-toxic.

Section 13 – Disposal Information

Disposal Information If this product as supplied becomes a waste, it does not meet the criteria of a hazardous waste as defined under the Resource Conservation and Recovery Act (RCRA) 40 CFR 261. Materials of a hazardous nature that contact the product during normal use may be retained on the product. The user of the product must identify the hazards associated with the retained material in order to assess the waste disposal options. Dispose according to federal, state and local regulations.

Section 14 – Transportation Information

U.S. Department of Transportation Shipping Name: Not classified as a hazardous material. Not regulated.

Transport Canada Product Identification Number Not classified as a hazardous material. Not regulated.

Section 15 – Regulatory Information (Not meant to be all inclusive - selected regulations represented)

TSCA Listed: Yes

OSHA: See section 8 above.

NIOSH: See section 8 above.
Animal tests conducted in 1976 - 1978. 18 month exposure at 15 mg / m³ showed silica deposition in respiratory macrophages and lymph nodes, minimum lung impairment, no silicosis.

ACGIH: See section 8 above.

DOT: Not classified as a hazardous material.

Canadian Hazardous Products Act This product is not classified as a controlled product under the regulations pursuant to the Federal Hazardous Product Act (e.g. WHMIS).

Canadian Environmental Protection Act All ingredients of this product are notified to CEPA and on the DSL(Domestic Substances List).

Section 16 – Other Information

HMIS – Hazardous Materials Identification System

HMIS Rating	
Health	1
Flammability	0
Physical	0

The HMIS rating information is intended solely for the use of individuals trained in the use of the HMIS rating system.

The NPCA specifically recommends that preparers of MSDSs should not place HMIS PPE designation codes on the MSDSs or labels that leave the facility as it is not known the conditions under which the customer will use this product.

This MSDS was prepared by: George E. Mckedy
Senior Applications Development Specialist
Multisorb Technologies, Inc.

This data and recommendations presented in this data sheet concerning the use of our product and the materials contained therein are believed to be correct but does not purport to be all inclusive and shall be used only as a guide. However, the customer should determine the suitability of such materials for his purpose before adopting them on a commercial scale. Since the use of our products is beyond our control, no guarantee, expressed or implied, is made and no responsibility assumed for the use of this material or the results to be obtained therefrom. Information on this form is furnished for the purpose of compliance with Government Health and Safety Regulations and shall not be used for any other purposes. Moreover, the recommendations contained in this data sheet are not to be construed as a license to operate under, or a recommendation to infringe, any existing patents, nor should they be confused with state, municipal or insurance requirements, or with national safety codes.

4250 Flow Meter

Index

Numerics

- 4-20 mA Output, 2-19, 4-4
 - Programming, 2-42
- 4200T Modem, 4-1

A

- Accessory/Options Parts List, A-6
- Accidental Submersion, 3-8
- Alarm Box, 2-24, 4-12
- Analog Output, 2-19, 4-4
 - Programming, 2-42
- Area-Velocity Sensor
 - Cleaning, 5-5
 - Maintenance, 5-5
 - Operating Principles, 1-3

B

- Battery Life Expectancy, 1-12
 - Calculating, 1-13
 - Calculating Current Draw, 1-14
 - Flow Meter Settings, 1-12

C

- Chart Paper Replacement, 5-8
- Compatible Equipment, 1-2
- Connectors, 1-8
- Controls, 1-8
- Current Draw, 1-14

D

- Display, 2-1
- Dissolved Oxygen Probe, 4-21

F

- Flow Conversion
 - Area-Velocity, 2-33
 - Data Points, 2-40
 - Equation, 2-38
 - Manning, 2-39
 - Weir/Flume, 2-36
- Flow Conversion Types, 2-5
- Flowlink Software, 4-12

H

- High-Low Alarm Box, 2-24, 4-12

I

- Indicators, 1-8
- Installation
 - AV Sensor, 3-12
 - Desiccant Canister, 3-1
 - Desiccant Cartridge, 3-1
 - Flow Meter, 3-7
 - Maximum Distance, 3-9
 - Parameter Probes, 4-13

K

- Keypad Functions, 2-2

L

- Language, 2-27
- Level Measurement, Open Channel, 3-13
- Low Power, 3-3

M

- Maintenance
 - Cable Inspection, 5-7
 - Case, 5-1
 - Desiccators, 5-2
 - Moisture Damage, 5-1
 - Printer, 5-8
 - Probe and Cables, 5-5
 - Software updates, 5-18
- Material Safety Data Sheets, D-1
- Maximum Head, 2-42
- Measuring Flow Meter Current, 1-15
- Modem, 4-1
- Mounting Rings
 - Universal Mounting Ring, 3-18
- MSDS, D-1

O

- Operating Mode, 2-11
- Operating Principles
 - 4250, 1-3
 - AV Sensor, 1-3
- Optional Equipment
 - Alarm Box, 2-19
 - Extension Cables, 3-11
 - External Analog Output Interface, 4-5
 - Flowlink, 4-12
 - Internal Multi-Analog Output Board, 4-6
 - Mechanical Totalizer, 4-29
 - Modem, 4-1

- Quick-Disconnect Box, 3-9
- Rain Gauge, 4-11
- Type 'E' Interface, 4-8
- Wastewater Sampler, 3-20
- Optional Outputs
 - Analog, 2-19, 4-4
 - Serial, 2-22, 4-4

P

- pacing non-Isco equipment, 4-8
- Parameter Probes, 4-13
 - D.O. (Dissolved Oxygen), 4-21
 - pH Probe, 4-15
 - Temperature Probe, 4-14
 - YSI 600 Sonde, 4-27
- Parameter Sensing, 4-13
- pH Probe, 4-15
- Power Sources, 3-3
 - AC, 3-5
 - External 12VDC, 3-6
 - Isco Sampler, 3-3
 - Lead-Acid Battery, 3-5
 - Nickel-Cadmium Battery, 3-4
- Programming, 2-3
- Programming Screens, 2-11
- Programming Steps
 - Description, 2-5
 - Step 1 - Program, 2-28
 - Step 2 - Flow Conversion, Area-Velocity, 2-33
 - Step 2 - Flow Conversion, Level-to-Flow Rate, 2-36
 - Step 3 - Parameter to Adjust, 2-43
 - Step 4 - Reset Totalizer, 2-49
 - Step 5 - Sampler Pacing, 2-49
 - Step 6 - Sampler Enable, 2-52
 - Step 7 - Alarm Dialout, 2-55
 - Step 8 - Printer, 2-57
 - Step 9 - Reports/History, 2-59
- Programming Worksheets, B-1

R

- Rain Gauge, 4-11
- Replacement Parts, A-1
- Reports, 2-24
- Ribbon Replacement, 5-10

S

- Safety Information, C-1
- Scissors Ring, 3-18
- Serial Output, 2-22, 4-4
 - ASCII Codes, 2-22
- Service and Troubleshooting
 - CMOS Circuitry, 5-16
 - Disassembling the Flow Meter, 5-11
 - Display Warnings, 5-13
 - Fuses, 5-12
 - Getting Help, 5-14

- Inspection Protocol, 5-14
- Preliminary Steps, 5-14
- Software Reset, 5-13
- Software
 - Flowlink, 4-12
 - Reset, 5-13
 - updates, 5-18

T

- Technical Specifications
 - 4250, 1-8
 - Low Profile Probe, 1-11
 - Standard Probe, 1-10
- Temperature Probe, 4-14
- Troubleshooting Steps, 5-14

W

- Wastewater Sampler, 3-20

Y

- YSI 600 Sonde, 2-8, 4-27
 - Calibration, 2-46
 - Programming Screens, 2-31

产品中有毒有害物质或元素的名称及含量

Name and amount of Hazardous Substances or Elements in the product

部件名称 Component Name	有毒有害物质或元素 Hazardous Substances or Elements					
	铅 (Pb)	汞 (Hg)	镉 (Cd)	六价铬 (Cr(VI))	多溴联苯 (PBB)	多溴二联苯 (PBDE)
线路板 Circuit Boards	X	O	O	O	O	O
显示 Display	X	O	O	O	O	O
接线 Wiring	O	O	O	O	X	O
小键盘 Keypad	O	O	O	O	X	O
直流电机 DC Motor	X	O	O	O	X	O
接头 Connectors	O	O	X	O	O	O

产品中有毒有害物质或元素的名称及含量：Name and amount of Hazardous Substances or Elements in the product

O: 表示该有毒有害物质在该部件所有均质材料中的含量均在ST/ 标准规定的限量要求以下。

O: Represent the concentration of the hazardous substance in this component's any homogeneous pieces is lower than the ST/ standard limitation.

X: 表示该有毒有害物质至少在该部件的某一均质材料中的含量超出ST/ 标准规定的限量要求。

(企业可在此处，根据实际情况对上表中打“X”的技术原因进行进一步说明。)

X: Represent the concentration of the hazardous substance in this component's at least one homogeneous piece is higher than the ST/ standard limitation.

(Manufacturer may give technical reasons to the "X"marks)

环保使用期由经验确定。

The Environmentally Friendly Use Period (EFUP) was determined through experience.

生产日期被编码在系列号码中。前三位数字为生产年(207 代表 2007 年)。随后的一个字母代表月份：

A 为一月，B 为二月，等等。

The date of Manufacture is in code within the serial number. The first three numbers are the year of manufacture (207 is year 2007) followed by a letter for the month. "A" is January, "B" is February and so on.

产品中有毒有害物质或元素的名称及含量

Name and amount of Hazardous Substances or Elements in the product

部件名称 Component Name	有毒有害物质或元素 Hazardous Substances or Elements					
	铅 (Pb)	汞 (Hg)	镉 (Cd)	六价铬 (Cr(VI))	多溴联苯 (PBB)	多溴二联苯 (PBDE)
线路板 Circuit Boards	X	O	O	O	O	O
外部电缆 External Cables	O	O	O	O	X	O

产品中有毒有害物质或元素的名称及含量：Name and amount of Hazardous Substances or Elements in the product

O: 表示该有毒有害物质在该部件所有均质材料中的含量均在ST/ 标准规定的限量要求以下。

O: Represent the concentration of the hazardous substance in this component's any homogeneous pieces is lower than the ST/ standard limitation.

X: 表示该有毒有害物质至少在该部件的某一均质材料中的含量超出ST/ 标准规定的限量要求。

(企业可在此处，根据实际情况对上表中打“X”的技术原因进行进一步说明。)

X: Represent the concentration of the hazardous substance in this component's at least one homogeneous piece is higher than the ST/ standard limitation.

(Manufacturer may give technical reasons to the "X"marks)

环保使用期由经验确定。

The Environmentally Friendly Use Period (EFUP) was determined through experience.

生产日期被编码在系列号码中。前三位数字为生产年(207 代表 2007 年)。随后的一个字母代表月份：

A 为一月，B 为二月，等等。

The date of Manufacture is in code within the serial number. The first three numbers are the year of manufacture (207 is year 2007) followed by a letter for the month. "A" is January, "B" is February and so on.

NOTICE

Disregard the following “Declaration of Conformity” and Radio Interference Statement” if your instrument does not have a CE label on its rear panel

Radio Interference Statement

FCC

This equipment has been tested and found to comply with the limits for a class A digital device, pursuant to Part 15 of the FCC Rules. These limits are designed to provide reasonable protection against harmful interference when the equipment is operated in a commercial environment. This equipment generates, uses, and can radiate radio frequency energy and, if not installed and used in accordance with the instruction manual, may cause harmful interference to radio communications. Operation of this equipment in a residential area is likely to cause harmful interference in which the user will be required to correct the interference at his own expense.

Canada

This ISM apparatus meets all requirements of the Canadian Interference-Causing Equipment Regulations.

Ce générateur de fréquence radio ISM respecte toutes les exigences du Règlement sur le matériel brouilleur du Canada.

DECLARATION OF CONFORMITY

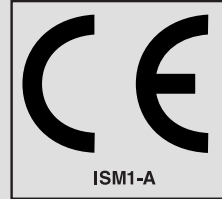

Application of Council Directive: 89/336/EEC – The EMC Directive
73/23/EEC – The Low Voltage Directive
Manufacturer's Name: Teledyne Isco, Inc.
Manufacturer's Address: 4700 Superior, Lincoln, Nebraska 68504 USA
Mailing Address: P.O. Box 82531, Lincoln, NE 68501
Equipment Type/Environment: Laboratory Equipment for Light Industrial/Commercial Environments
Trade Name/Model No: Model 4250 Area-Velocity Flow Meter
Year of Issue: 2000

Standards to which Conformity is Declared: EN 50082-1 Generic Immunity for Commercial, Light Industrial Environment
EN 61010-1 Safety Requirements for Electrical Equipment for Measurement, Control, and Laboratory Use

Standard	Description	Severity Applied	Performance Criteria
IEC 801.2	Electrostatic Discharge	Level 2 - 4kV contact discharge Level 3 - 8kV air discharge	B B
IEC 801.3	Radiated RF Immunity	27 MHz to 500MHz *Level 2 - 3 V/m	A
IEC 801.4	Electrical Fast Transient	Level 2 - 1kV on ac lines	B
CISPR11/ EN 55011	RF Emissions	Group 1, Class A Industrial, Scientific, and Medical Equipment	

We, the undersigned, hereby declare that the design of the equipment specified above conforms to the above Directive(s) and Standards as of September 13, 2000

William Foster
USA Representative



William Foster
Director of Engineering
Teledyne Isco, Inc.
4700 Superior Street
Lincoln, Nebraska 68504
Phone: (402) 464-0231
Fax: (402) 464-4543

60-3252-017
Rev. A

Teledyne Isco One Year Limited Factory Service Warranty*

This warranty exclusively covers Teledyne Isco instruments, providing a one-year limited warranty covering parts and labor.

Any instrument that fails during the warranty period due to faulty parts or workmanship will be repaired at the factory at no charge to the customer. Teledyne Isco's exclusive liability is limited to repair or replacement of defective instruments. Teledyne Isco is not liable for consequential damages.

Teledyne Isco will pay surface transportation charges both ways within the 48 contiguous United States if the instrument proves to be defective within 30 days of shipment. Throughout the remainder of the warranty period, the customer will pay to return the instrument to Teledyne Isco, and Teledyne Isco will pay surface transportation to return the repaired instrument to the customer. Teledyne Isco will not pay air freight or customer's packing and crating charges. This warranty does not cover loss, damage, or defects resulting from transportation between the customer's facility and the repair facility.

The warranty for any instrument is the one in effect on date of shipment. The warranty period begins on the shipping date, unless Teledyne Isco agrees in writing to a different date.

Excluded from this warranty are normal wear; expendable items such as pH sensors, charts, ribbon, lamps, tubing, and glassware; fittings and wetted parts of valves; and damage due to corrosion, misuse, accident, or lack of proper maintenance. This warranty does not cover products not sold under the Teledyne Isco trademark or for which any other warranty is specifically stated.

No item may be returned for warranty service without a return authorization number issued by Teledyne Isco.

This warranty is expressly in lieu of all other warranties and obligations and Teledyne Isco specifically disclaims any warranty of merchantability or fitness for a particular purpose.

The warrantor is Teledyne Isco, 4700 Superior, Lincoln, NE 68504, U.S.A.

*** This warranty applies to the USA and countries where Teledyne Isco does not have an authorized dealer. Customers in countries outside the USA, where Teledyne Isco has an authorized dealer, should contact their Teledyne Isco dealer for warranty service.**

Before returning any instrument for repair, please call, fax, or e-mail the Teledyne Isco Service Department for instructions. Many problems can often be diagnosed and corrected over the phone, or by e-mail, without returning the instrument to the factory.

Instruments needing factory repair should be packed carefully, and shipped to the attention of the service department. Small, non-fragile items can be sent by insured parcel post. **PLEASE BE SURE TO ENCLOSE A NOTE EXPLAINING THE PROBLEM.**

Shipping Address: Teledyne Isco - Attention Repair Service
4700 Superior Street
Lincoln, NE 68504 USA

Mailing Address: Teledyne Isco
PO Box 82531
Lincoln, NE 68501 USA

Phone: Repair service: (800) 775-2965 (lab instruments)
(866) 298-6174 (samplers & flow meters)
Sales & General Information: (800) 228-4373 (USA & Canada)

Fax: (402) 465-3001

Email: IscoService@teledyne.com



October 11, 2013 P/N 60-1002-040 Rev H

