

# Industrial Pre- and Post-Treatment Monitoring

## Application Note

## Expertise in Flow

### Signature® Flow Meter



#### Standard Features:

- Multiple parameter data logging
- Program & summary reports
- Data integrity verification
- Triggering, sampler enabling
- Compatibility with Flowlink® software
- Multiple simultaneous flow technologies
- pH and temperature input
- SDI-12 input
- RS-485 input
- RS-485 output
- Analog outputs
- Remote communication via cell phone or Ethernet

### TIENet™ 306 Sampler Interface



The TIENet Model 306 Sampler Interface connects the Signature Flow Meter to a Teledyne Isco wastewater sampler. Through this connection, the Signature can enable the sampler based on user-specified conditions, pace the sampling routine based on flow, and receive sample and bottle information from the sampler.

*In order to assess the effects of chemicals injected into wastewater discharge, it is often necessary to monitor the wastewater both before and after treatment, ready to capture samples for further analysis when pH issues are detected in the water. With the creative know-how of Teledyne Isco's Environmental Product Support (EPS) and Special Product Applications (SPA) teams, a system controlled by the Signature Flow Meter can not only control a compliance sampler while monitoring the level and pH at the influent and effluent simultaneously; it can also regulate the chemical dosing of both caustic and acid pumps.*

### A Minimal System for a Complex Job

pH levels may fluctuate from day to day, depending on what processes are going on at a facility. Whenever the discharge pH is too low or too high, caustic and acid pumps must deliver the precise chemical dosage needed to maintain safe pH levels.

Such a monitoring system requires the ability to transmit and totalize flow, trigger recirculation and chemical injection pumps, and take samples to meet compliance. The challenge becomes building a system capable of all of these tasks while keeping complexity and cost to a minimum.

### Multiple Functions on a Common Platform

The base meter for multiparameter monitoring, triggering, and data transmission is the Signature Flow Meter. With multiple TIENet™ interface options and multiparameter measurement and logging, the Signature provides a common platform for control action, reporting, and communication.

### System Design and Functionality

With a built-in **330 Bubbler** and measurement range of 0.01 to 10 feet, the Signature is able to constantly monitor the liquid level, exporting flow data to an external control system as an analog signal using an internal **308 4-20 mA Output Card**.

With **two 301 pH Devices**, the Signature can monitor pH levels at locations before and after chemical injection.

All in all, **five 306 Sampler Interface Devices** are used in this system. The first one simply transmits data and commands between the Signature and sampler. The other four 306 devices are modified so that the enable signal turns into a relay contact, which triggers the recirculation and chemical pumps based on pH and level readings.

A total of ten TIENet devices—seven external and three internal, including the case board—are operated simultaneously by the Signature Flow Meter. Physically, this is made possible with the addition of two TIENet expansion boxes, which enable the connection of multiple devices and increased distance to the flow meter.

Each TIENet device is operated independently by the Signature, with its own individual programming sequence. For example, the 306 modified to control the caustic pump is activated only when the liquid level is above 0.03 feet AND when the pretreatment pH level is less than or equal to 6.0. The equation 1Caustic can now be selected as a trigger for one of the connected 306 devices—#1, for instance.

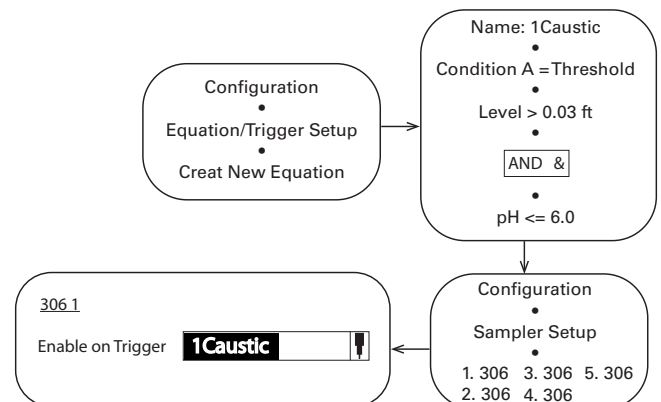

Note: Multiple 306 devices will appear differentiated by serial number.

## TIENet™ Expansion Box



- Rated IP67 (NEMA 4X, 6) w/ appropriate ID conduit connection, cord-grip fittings, or plugs
- Up to 3 TIENet terminal connections
- Option card mounting

For detailed information about the TIENet Expansion Box and custom networking, including reference air support, refer to Application Note [AN07 Signature Flow Meter Expansion Box](#).

## TIENet™ 308 4-20mA 2-Channel Analog Output Card



- Two separately scalable current outputs
- Up to three internal cards accepted, for a possible 6 simultaneous output channels
- Additional cards possible when installed in an Expansion Box

Meanwhile, the 306 modified to control the acid pump is activated only when the liquid level is above 0.03 feet AND when the pretreatment pH level is greater than or equal to 8.0, with 306 #2 triggered by the equation 1Acid, and so on.

## System Components

The system described in this application note is only an example of the many configurations made possible with the flexibility of the Signature Flow Meter and associated equipment.

**Table 1: Component Descriptions**

System Component	Qty	Description & Function in this Example
Signature Bubbler Flow Meter	1	Central base meter. Intelligently manages all associated equipment operations with separate, independent programming.
TIENet 306 Sampler Interface 60-5324-013	1	Modified Interface. Delivers momentary contact closure for each flow pulse to a non-Isco sampler.
TIENet 306 Sampler Interface 60-5324-013	2	Modified Interface. Triggers a chemical feed pump based on level & pH values.
TIENet 306 Sampler Interface 60-5324-037	2	Modified Interface. Triggers a circulation pump based on level. Uses a 30A relay.
TIENet 308 4-20 mA Output Card	1	Internally installed in Signature. Outputs 1 or 2 analog signals (in this case, flow)
TIENet Network Expansion Box	2	Supports multiple connections in a daisy-chain formation, allowing addition of system components and longer distances. (Cord grips ordered separately.)
TIENet 301 pH & Temperature Interface	2	Measures pH level at the pre- or post-treatment site.

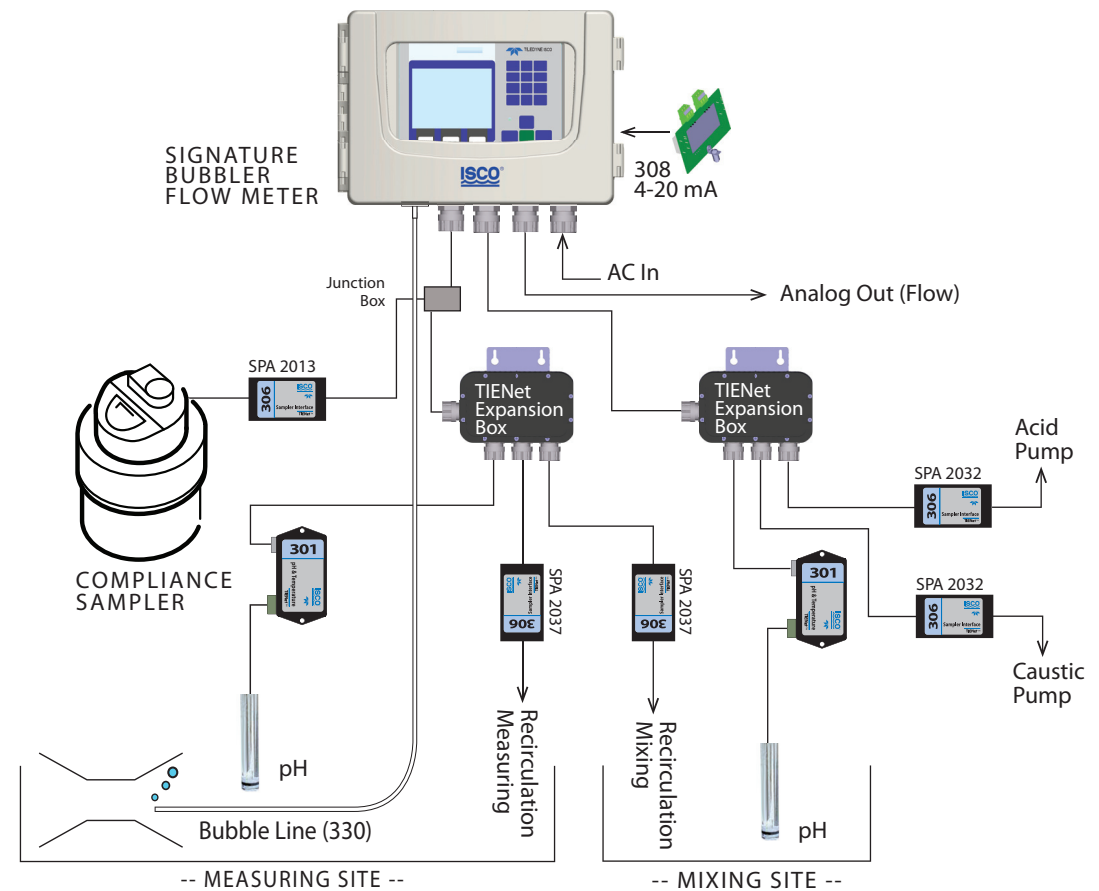

**Connection Diagram of the Measurement Site**

## Teledyne ISCO

P.O. Box 82531, Lincoln, Nebraska, 68501 USA  
 USA & Canada: (800) 228-4373 • Phone: (402) 464-0231 • Fax: (402) 465-3091  
 Web site: [www.teledyneisco.com](http://www.teledyneisco.com)

Teledyne ISCO is continually improving its products and reserves the right to change specifications without notice.  
 ©2013 Teledyne Technologies Incorporated L-0204-AN09 05/13

