

Gradient Pumping for Pressure, Flow, and Concentration Modes

With Teledyne Isco Syringe Pumps



Syringe Pump Technical Bulletin
TB24

Overview

Gradient pumping is used in applications requiring time-controlled or rate-controlled delivery of a specific volume at a set flow rate or pressure, or a two-pump flow concentration.

All Teledyne Isco syringe pump models can be used in gradient mode. The model 65D requires special hardware for this. Call the factory for complete information.

You can program the controller to increase or decrease pressure or flow during different steps within a single program by entering a specific value at the beginning and end of each step.



DANGER

RISK OF INJURY. THE PRESSURE PRODUCED COULD BE 700 BAR. PLEASE UTILIZE APPROPRIATE TUBING AND CONNECTIONS NOTED IN YOUR USER MANUAL.

Tools and Parts for Single Pump System

Open-end wrenches: 1/4", 5/16", 7/16", 3/8"
Manual Refill Valve Kit - see Table 1
Manual Outlet Valve Kit - see Table 2

Tools and Parts for Dual Pump System

Open-end wrenches: 1/4", 5/16", 7/16", 3/8"
Manual Refill Valve Kit - see Table 1 (two kits required)
Gradient Mixer Package - part #68-1247-080

Table 1: Manual Refill Valve Kits

Pump Model	Part Number
1000D	68-1247-117
500D	68-1247-083
65DM, 100DM/DX, 260D	68-1247-077
65D	68-1247-127

Table 2: Manual Outlet Valve Kits

Pump Model	Part Number
1000D	68-1247-118
500D	68-1247-082
65DM, 100DM/DX, 260D	68-1247-078
65D	68-1247-126

Connecting the System

The syringe pump has two ports at the top of the cylinder. One port is used as the inlet for filling the pump, and the other as the outlet (either port may be used as inlet or outlet). Inlet and outlet connections to each pump must be made identically. Standard plumbing connections vary between pump models. See Table 3 below for standard port information.

When making fluid connections that use ferrules, be sure to use the ferrules supplied for that pump by Teledyne Isco. Push the tubing completely into the connector and finger-tighten. Then tighten with a wrench to clamp the ferrules onto the tubing.

Table 3: Standard Port Connections

Pump	Ports	Swaging Detail
65DM, 100DM/DX, 260D	1/8" Valco	<p>FERRULE NUT 5-16 - 24 1/2 TURN PAST FINGER-TIGHT</p>
500D	1/8" NPT	<p>FRONT FERRULE NUT 5-16 - 24 BACK FERRULE 3/4 TURN PAST FINGER-TIGHT</p>
1000D	1/4" NPT	<p>FRONT FERRULE NUT 7-16 - 20 BACK FERRULE 1-1/4 TURN PAST FINGER-TIGHT</p>
65D	1/4" F250C	Call Teledyne Isco.

Note

Pump models 260D, 100DM/DX, and 65DM have a direct connection, as shown in Figures 1 and 2 on the following page. Valve kits for other models include male adapter fittings.

A gradient pumping system includes high-pressure, two-way valves that connect the pump inlets to fluid reservoirs, and the pump outlets to the gradient mixer (dual pump system) or other apparatus (single pump system). Each refill kit and outlet valve package contains one two-way valve; the gradient package contains two. The kits contain all tubing and hardware necessary for valve installation.

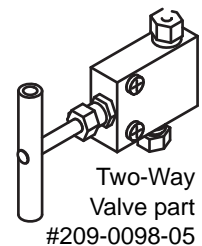

Following installation, the tubing connections must be tested for leaks before any program is run.

If a leak is found, tighten the connection slightly. If the leak persists, swage the connection again with a new ferrule. Refer to Technical Bulletin [TB05 Field Verification Procedures](#) for leak test procedures.

Inlet Connections

Kit components and connections are shown in Figure 1 on the following page.

1. Mount the inlet valve on the pump housing with the spacer block and screws provided.
2. Connect the pre-bent SST tubing from one port of the valve to the pump inlet. Use the nut and ferrule to connect the tubing at the inlet and the valve fittings to connect the tubing at the valve.
3. Connect the PTFE refill tubing (with the filter) to the other port of the valve, using the nuts and ferrules supplied.

☑ Note

When connecting to pressurized sources in supercritical fluid applications, use the stainless steel tubing **without** a filter. An in-line filter is contained in the CO₂ connection package (refer to technical bulletin [TB08 CO₂ Applications and Technical Notes](#)).

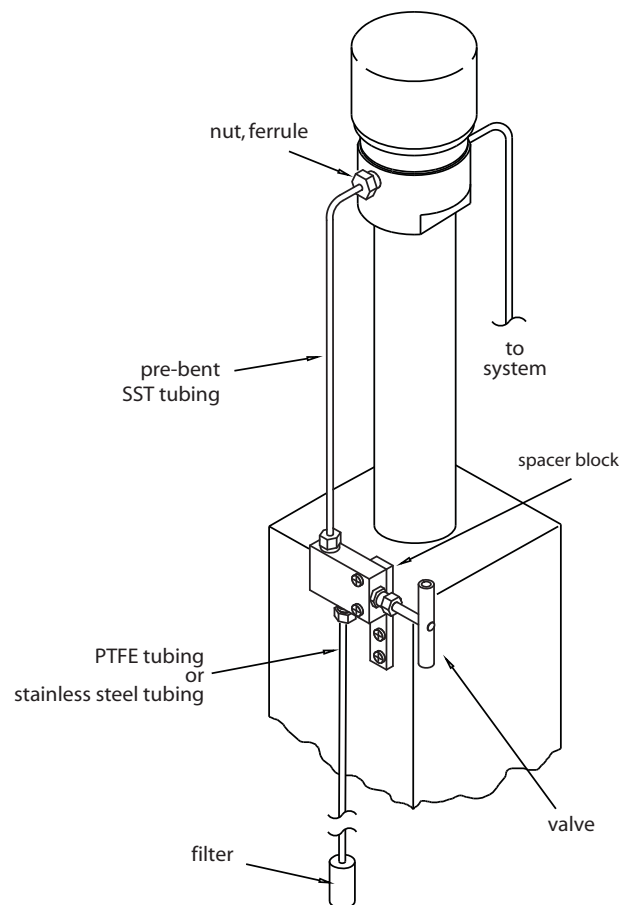

Figure 1: Pump inlet connections

Outlet Connections

Kit components and connections are shown in Figure 2.

1. Mount the two-way outlet valve on the side of the pump housing opposite the refill valve, with the spacer block and screws provided.
2. Connect the pre-bent SST tubing between one port of the valve and the pump outlet. Use the nut and ferrule to connect the tubing at the outlet and the valve fittings to connect the tubing at the valve.
3. Connect the 5.1 cm length of 1/8" tubing to the other port of the valve, using the valve fittings.
4. Connect the 1/8" side of the reducing union to the tubing.
5. Connect the 1/16" side of the reducing union to the 1.5 m length of 1/16" tubing. (This tubing may be cut to an appropriate length.)

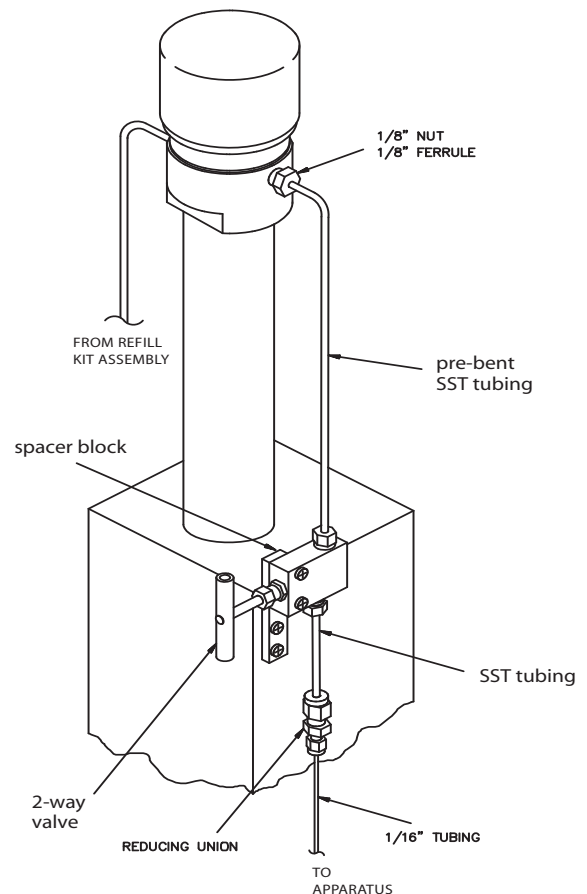

Figure 2: Pump outlet connections

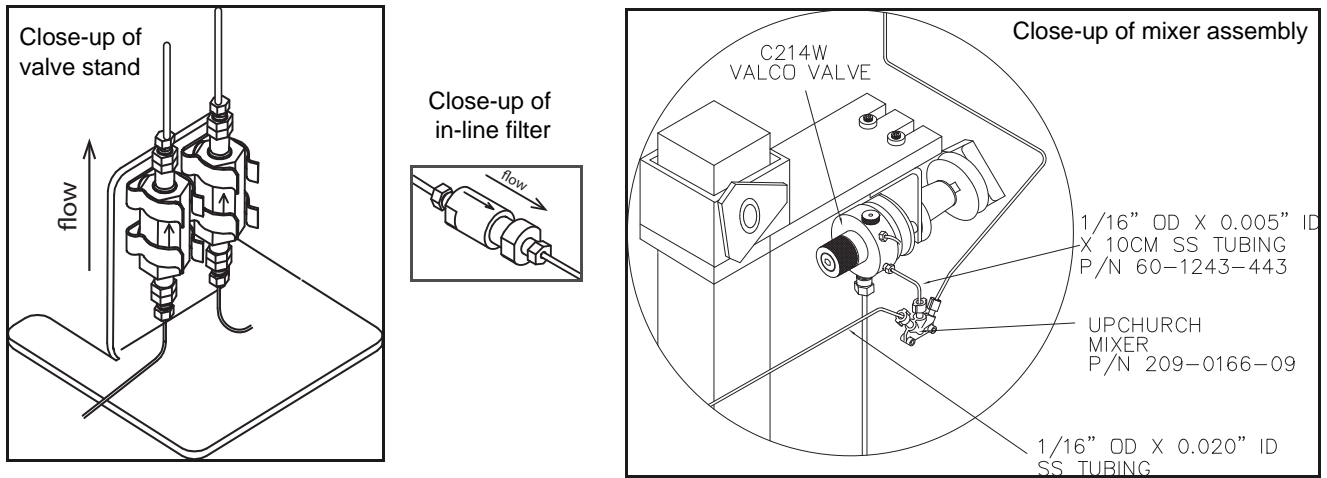

Figure 4: Dual gradient connections: Detail

The home screen will appear, with either PG (Pressure Gradient) or FG (Flow Gradient) in the upper left corner.

Single-Pump Gradient Programming

A single-pump gradient program is based on either pressure or flow, and controlled by either time duration (in minutes) or rate of change (units per minute).

The controller’s memory can contain a total of up to 200 steps. One program can contain from 1 to 200 steps.

When operating in gradient mode, any connected pumps not used for gradient are inoperable.

1. To access the gradient programming menus, press PRGM GRAD, and follow the sequence shown below.

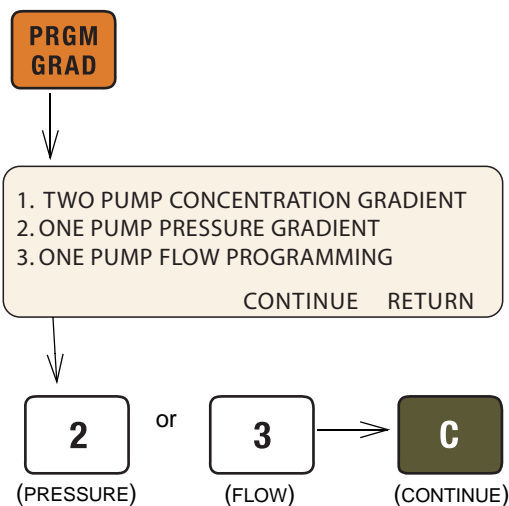

PGa	0.000mL/MIN	2PSI	013.28mL
STOPPED	FILE:1	00:00:00	
	/MIN	FINAL: PSI	
PROGRAM	EDIT	REVIEW	OPTION

2. Press PROGRAM (A).
3. At the prompt, enter a file number between 1 and 99. This is the file name of your program, and can be the name of a new program you are creating, or a stored program you want to edit or run. Press ENTER.

Note

If a selected stored program is in a different mode than that of the controller selected in Step 1, a brief notification will appear, displaying the controller’s mode and the file’s mode. If you attempt to run the program without changing the mode of either it or the controller, the program will not run, and the same message will be displayed.

4. To enter the flow rate for this program, either press FLOWRATE (A) and use the number keys and Enter, or for maximum possible flow, simply press MAX (C).

	ENTER FLOWRATE	
	0.00000	XX.00000
↓	FLOWRATE	PREVIOUS MAX

- To proceed to the programming screen, press STEP FWD (B).
The programming screen will appear, with the file number and step number at the top of the screen.

```
PGa FILE# 1 STEP# 1 STORE TO EXIT
1. INIT = 0PSI 3. RATE = 0:00PSI/MIN
2. FINAL = 0PSI 4. DURATION = 1.0MIN
INSERT DELETE
```

or

```
FGa FILE# 1 STEP# 1 STORE TO EXIT
1. INIT% = 3. RATE = 0.00%/MIN
2. FIN% = 4. DURATION = 1.0MIN
INSERT DELETE
```

- To set the initial pressure or flow for this step, press INIT (1) to activate this parameter. Use the number keys to enter the desired value, then press ENTER to save it.
- To set the final pressure or flow for this step, press FINAL (2) to activate this parameter. Use the number keys to enter the desired value, then press ENTER to save it.
- Set either the desired RATE (3) of change or DURATION (4) in minutes. Once one value has been set and saved, the other will automatically appear.

Note

DURATION in minutes can have a resolution of 0.1, with a maximum of 9,999 minutes per step.

- If you want to add another step to the file program, press INSERT (C).
The step number will increase by one, and the default initial value will be the final value entered for the previous step. Edit as desired.
- When programming is complete, press the STORE key to save the file and return to the home screen.
- To start the program, press RUN two times.

Note

When a gradient run is started, digital output **8** of the controller ACCESSORY connector will toggle from high to low (open to closed) for one second.

Note that an entire gradient program can be removed only by deleting each of its steps one at a time, as discussed in *Review, Revise, & Hold Options*. When the last remaining step is deleted, the entire file is removed.

Dual Pump Concentration Gradient Programming

Two-pump concentration gradients enable proportionate use of two different fluids that combine at the mixer (refer to Figures 3 and 4).

This type of pumping uses flow mode (FG) only. A single-pump gradient program is based on either pressure or flow, and controlled by either time duration (in minutes) or rate of change (units per minute).

The controller's memory can contain a total of up to 200 steps. One program can contain from 1 to 200 steps.

When operating in gradient mode, any connected pumps not used for gradient are inoperable.

- To access the gradient programming menus, press PRGM GRAD, and follow the sequence shown below.

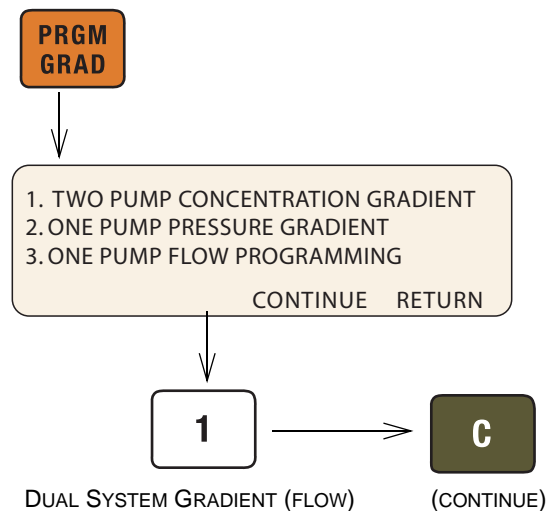

The home screen will appear, with FG (Flow Gradient) in the upper left corner.

```
FGa 0.000mL/MIN 2PSI 013.28mL
STOPPED FILE:1 00:00:00
FINAL: %B
PROGRAM EDIT REVIEW OPTION
```

- Press PROGRAM (A).
- At the prompt, enter a file number between 1 and 99. This is the file name of your program, and can be the name of a new program you are creating, or a stored program you want to edit or run. Press ENTER.

Note

If a selected stored program is in a different mode than that of the controller selected in Step 1, a brief notification will appear, displaying the controller's mode and the file's mode. If you attempt to run the program without changing the mode of either it or the controller, the program will not run, and the same message will be displayed.

- To enter the flow rate for this program, either press FLOWRATE (A) and use the number keys and Enter, or for maximum possible flow, simply press MAX (C).

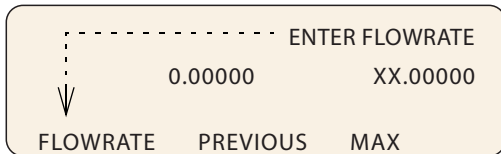

- To proceed to the programming screen, press STEP FWD (B). The programming screen will appear, with the file number and step number at the top of the screen.

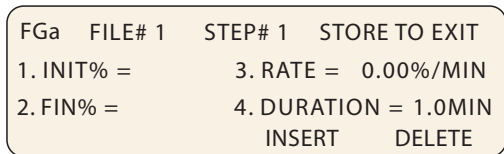

- To set the initial pressure or flow for this step, press INIT (1) to activate this parameter. Use the number keys to enter the desired value, then press ENTER to save it.
- To set the final pressure or flow for this step, press FINAL (2) to activate this parameter. Use the number keys to enter the desired value, then press ENTER to save it.
- Set either the desired RATE (3) of change or DURATION (4) in minutes. Once one value has been set and saved, the other will automatically appear.

Note

DURATION in minutes can have a resolution of 0.1, with a maximum of 9,999 minutes per step.

- If you want to add another step to the file program, press INSERT (C). The step number will increase by one, and the default initial value will be the final value entered for the previous step. Edit as desired.
- When programming is complete, press the STORE key to save the file and return to the home screen.
- To start the program, press RUN two times.

Note

When a gradient run is started, digital output 8 of the controller ACCESSORY connector will toggle from high to low (open to closed) for one second.

The flow rates and ramp rate for Pump A in each step will be in direct opposite proportion to the values set for Pump B (INIT%B, FIN%B, and RATE).

Note that an entire gradient program can be removed only by deleting each of its steps one at a time, as discussed in the next section, *Review, Revise, & Hold Options*. When the last remaining step is deleted, the entire file is removed.

Review, Revise, & Hold Options

While in the programming menu, you can also:

Delete – To delete the current step, press DELETE (D). A deleted step cannot be recovered. Used repeatedly, this command can be used to delete an entire file.

Review – To review existing program steps, press STEP BACK (A) or STEP FWD (B).

Add New – To add a new step between two existing steps, navigate through the program to the step just before your addition. Press INSERT (C) and program the new step.

Note that the initial value of the next step will default to the final value of the new step, and may need to be edited if a different initial value is needed.

While Running – A gradient program can be reviewed or edited while it is running. Simply press EDIT (B) or REVIEW (C) to begin.

If a new step duration is shorter than the elapsed time for that step, the program will proceed to the next step. If the total flow rate is changed, the program will immediately start using the new rate.

To return to the run screen, press RETURN (D).

Hold – You can hold a running gradient in its current state while retrieving a different program file to run in its place. Press Hold and then Recall to access the new program.

This feature is used mainly in applications where it is necessary to keep the system pressurized during method changes.

External Start – When a gradient program is in Hold mode, a momentary low on digital input 2 of the controller ACCESSORY connector will start the program.

Program Conclusion

When a gradient program reaches the end, there are four selectable actions the system can then perform:

- Hold the final value (*example below*)
- Stop after the final step
- Return to the initial value and hold it
- Return to the initial value and repeat the program

While the system is in gradient mode, these options can be edited at any point before or after gradient programming, and while a gradient is running.

To access the options menu, from the home screen, press OPTIONS (D).

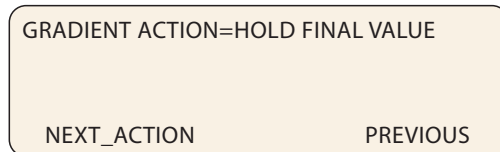

To scroll through the four options, press NEXT_ACTION (A). When you have reached the desired option, press PREVIOUS (D) to save and exit.

Teledyne Isco

P.O. Box 82531, Lincoln, Nebraska, 68501 USA
Toll-free: (800) 775-2965 • Phone: (402) 464-0231 • Fax: (402) 465-3001
E-mail: IscoService@teledyne.com

Teledyne Isco is continually improving its products and reserves the right to change product specifications, replacement parts, schematics, and instructions without notice.

